

# Junkkari

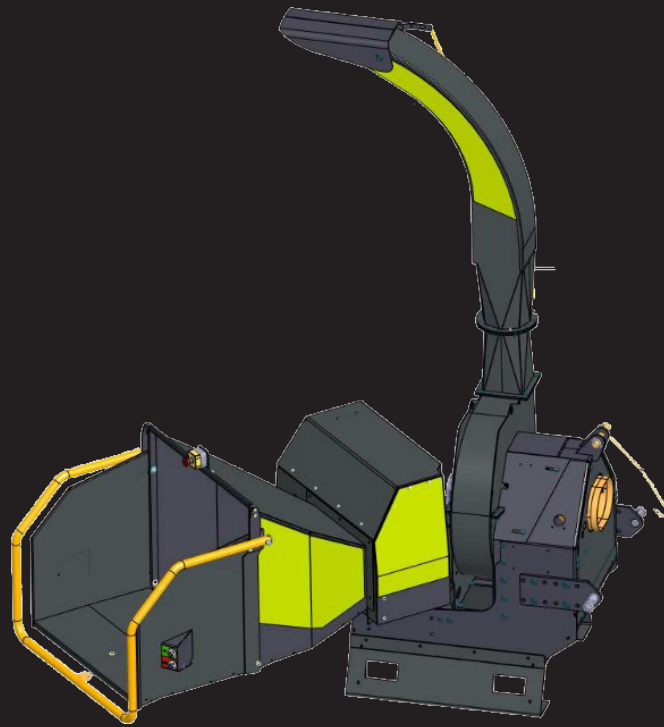

**A GOOD WAY TO WORK HARD**

**JUNKKARI HJ 172/252/262**

**CHIPPER**

**OPERATING INSTRUCTIONS**

# CONTENTS

<b>1 DEAR CUSTOMER</b> .....	<b>3</b>
<b>2 TECHNICAL SPECIFICATIONS</b> .....	<b>4</b>
<b>3 SAFETY INSTRUCTIONS</b> .....	<b>5</b>
3.1 GENERAL SAFETY INSTRUCTIONS.....	5
3.2 DWELL TIMES.....	5
3.3 TRANSPORTATION AND TRANSFER.....	5
3.4 UNIVERSAL DRIVE SHAFT.....	6
3.5 HYDRAULICS.....	6
<b>4 WARNING STICKERS, SAFETY COMPONENTS AND SERIAL NUMBER PLATE</b> .....	<b>7</b>
4.1 SERIAL NUMBER PLATE.....	8
<b>5 OPERATING ENVIRONMENT</b> .....	<b>9</b>
5.1 INTENDED USE.....	9
5.2 LIMITATIONS OF USE AND PROHIBITED USES.....	9
<b>6 PRINCIPLE OF OPERATION</b> .....	<b>10</b>
6.1 PRINCIPLE OF OPERATION.....	10
6.2 NO-STRESS FEATURE.....	10
<b>7 TRANSPORTATION, HANDLING AND STORAGE</b> .....	<b>11</b>
7.1 TRANSPORTATION.....	11
7.2 HANDLING.....	11
7.3 STORAGE.....	11
7.4 SPECIAL SAFETY INSTRUCTIONS FOR MACHINE TRANSPORTATION.....	11
<b>8 IMPLEMENTATION</b> .....	<b>12</b>
8.1 PREPARATIONS PRIOR TO OPERATING.....	12
8.2 PACKAGE DISPOSAL.....	12
8.3 ATTACHMENT TO A TRACTOR.....	12
<b>9 UNIVERSAL DRIVE SHAFT</b> .....	<b>13</b>
<b>10 ADJUSTMENTS</b> .....	<b>14</b>
10.1 BLADE SETTING ADJUSTMENT.....	14
10.2 FEEDING DEVICE SPEED ADJUSTMENT.....	15
<b>11 OPERATION</b> .....	<b>16</b>
<b>12 MAINTENANCE</b> .....	<b>17</b>
12.1 SHARPENING THE CUTTING BLADES.....	17
12.2 LUBRICATION.....	17
<b>13 TROUBLESHOOTING CHART</b> .....	<b>18</b>
<b>14 WITHDRAWAL FROM SERVICE</b> .....	<b>19</b>
<b>15 TERMS OF WARRANTY</b> .....	<b>20</b>
<b>16 LIABILITY</b> .....	<b>21</b>
<b>17 ASSURANCE OF COMPLIANCE WITH EC REGULATIONS</b> .....	<b>22</b>

# 1 DEAR CUSTOMER

We thank you for the trust you place in us and wish you the best of success in your endeavours. We invite you to read these instructions for use thoroughly, since familiarity with the machine, accurate adjustments and careful maintenance will guarantee the user's safety and the continuous operation of the machine on busy workdays.

It is important to understand each section of this booklet and to adhere to the instructions for use. If you have any questions or doubts, you should contact the vendor.

We hope that you will return the signed warranty to the manufacturing plant once you have read the instructions for use.



## **Warning**

This symbol is always used in the instructions if there is a danger to the user or to others.

In addition, this symbol is used to indicate risks to the environment or to property.

## 2 TEKNICAL SPECIFICATIONS

Type	HJ 172G	HJ 172GT	HJ 252G	HJ 252GT	HJ 252GTC
Disc diameter, mm	630	630	800	800	800
Disc weight, kg	97	97	170	170	170
Rotational speed r/min	540-1000	540-1000	540-1000	540-1000	540-1000
Number of blades	4	4	4	4	4
Chip size, mm	5-18	5-18	3-15	3-15	3-15
Max. wood diameter, mm	170	170	250	250	250
Chipping capacity m <sup>3</sup> /h	4-8	4-8	7-20	7-20	7-20
Power requirement hv/kW	30-70/22-51	30-70/22-51	30-75/22- 55	30-75/22- 55	30-75/22-55
Weight kg	672	727	825	878	854
Height in transportation position mm	3010	3010	3190	3190	3190
Feed opening size, mm	200x200	200x200	260x260	260x260	260x260
Feeding device	Yes(*)	Yes(*)	Yes(*)	Yes (*)	Yes (**)

Type	HJ 262G	HJ 262GT	HJ 262GTC
Disc diameter, mm	940	940	940
Disc weight kg	240	240	240
Rotational speed r/min	540-1000	540-1000	540-1000
Number of blades	4	4	4
Chip size, mm	3-20	3-20	3-20
Max. wood diameter, mm	260	260	260
Chipping capacity m <sup>3</sup> /h	7-20	7-20	7-20
Power requirement, hv/kW	30-75/40-100	30-75/40-100	30-75/40-100
Weight, kg	809	864	840
Height in transportation position, mm	2910	2910	
Feed opening size, mm	265x265	265x265	
Feeding device	Yes (*)	Yes (**)	

\* Tractor hydraulics

\*\* Device hydraulics

Type: \_\_\_\_\_  
 Manufacturing number: \_\_\_\_\_  
 Model: \_\_\_\_\_

## 3 SAFETY INSTRUCTIONS



### 3.1 GENERAL SAFETY INSTRUCTIONS

- CLOTHING: For your own safety, wear fitted clothing with no hanging sleeves.
- OPERATION: Before operating the machine, read the instructions on how to connect, adjust and operate it.
- WARNINGS: Follow all machine warnings and instructions.
- SAFEGUARDS: The machine may only be operated with all safeguards in place and intact. Always wear a helmet, ear protectors and eye protectors (forest worker's helmet) when chipping.
- ATTACHMENT TO TRACTOR: Take special care when attaching or removing the machine.
- TOWING DEVICE LOAD: Consider the maximum loads for the drawbar and the tractor drawing device.
- PARKING: Ensure that the parked machine cannot move.
- SAFETY DISTANCE: Due to its principle of operation, the machine contains components that cannot be entirely safeguarded. You should always stay within a safe distance from these components. The driver should also ensure that bystanders cannot get close to these components. The safety distance of a chipper with loader feeding equipment is 20 m.
- OPERATING THE MACHINE: No one can stay in the vicinity of the machine when it is in operation.
  - Never go between the machine and the tractor if the machine is being lifted, lowered or moved.
  - Do not go under or on top of a machine that only stands on its hydraulic components without support.
  - Before operating the machine, ensure that it is correctly connected and that the safeguards are in place.
  - Before working with the machine, always verify that no one is in the immediate vicinity of the machine.
  - After operation, check the condition of the machine, particularly its attachment and connection points.



**THE VOLUME OF THE OPERATION SITE IS OVER 85 DB.  
ALWAYS USE EAR PROTECTORS DURING CHIPPING.**

### 3.2 DWELL TIMES

The Junkkari chipper's dwell times are as follows:

Loaded	15	seconds
Unloaded	90	seconds

### 3.3 TRANSPORTATION AND TRANSFER

- Always observe the Road Traffic Act when driving on public roads.
- Inspect and install all equipment required for transportation on public roads, such as lights, reflectors and the slow vehicle triangle.
- Observe maximum shaft weights, total weights and transportation dimensions allowed.
- All devices moving the machine, such as chains, racks etc., must be placed so that involuntary movement cannot affect them in the machine working or transportation position.
- The machinery or additional weight in tow or on the lifting device may affect the behaviour of the tractor during transportation, i.e. its control and the operation of the brakes. This is why it is important for sufficient control and braking action to always be available.
- Passengers may not be transported on top of the machine.
- The machine may only be lifted at the points indicated with instruction stickers.
- Only use approved lifting straps or chains and check to ensure they are in good condition.
- If the machine is moved e.g. onto a platform, it should be secured with chains or straps.
- When loading e.g. with a forklift, check that the machine is on balance and that there is no danger of it falling.

## 3.4 UNIVERSAL DRIVE SHAFT

- Always switch the power take-off drive when leaving the tractor cabin.
- Ensure that the PTO shaft's safety tubes do not rotate with the shaft inside. Carefully attach the Check chain.
- When the machine is transported on public roads, the driver should ensure that the PTO has been switched off.
- Before the power take-off is switched on, ensure that no one is standing near the rotating PTO shaft.
- The universal drive shaft may only be installed once the PTO shaft of the machine has been switched off, the engine has been stopped and the key has been removed from the ignition switch.
- When starting the engine, the power take-off must be switched off.
- The tractor power take-off rotational speed must correspond to the operating speed range of the machine's drive mechanism.
- The limits set for the PTO rotational speed must be fully observed. Speeds exceeding the limits will damage the machine.
- The PTO shaft should be switched off when not needed or when the tractor and the machinery are at a very steep articulation angle.
- Before the universal drive shaft is switched on for rotation and during its rotation, ensure that no one is in the danger area of the rotating drive shaft.
- Only use CE-labelled universal drive shafts approved by the manufacturer. All PTO safeguards, shields and the tractor PTO guard must be in place and in good condition.
- Never use a damaged drive shaft, since this involves a serious risk of accident. The damaged shaft should be repaired before it is used again.
- Please note that the shaft tubes of the drive shaft overlap in both the transportation and the working position.
- After the drive shaft is shortened, the splined ends should be cleaned and carefully greased.
- The universal drive shaft should only be installed and removed when the tractor power take-off shaft is switched off. Never use the switch alone to disengage the transmission drive to the PTO.
- Once the universal drive shaft has been installed, its securing peg must engage in the locking position in the POT shaft groove. Ensure that the shaft is securely in place.
- Attach the drive shaft shield securing chain so that the shield cannot rotate.
- Place the removed drive shaft on a suitable support.

## 3.5 HYDRAULICS

- After the connection, the hydraulics system is under high pressure. Hydraulic oil released with high pressure will penetrate the skin and may cause serious injuries. There is also a risk of injury when searching for leakages.
- Be careful with all hydraulic components. They involve the risk of getting cut or trapped between components.
- When a hydraulic hose is connected to the tractor, the hydraulic systems of both units must be Non-pressurised.

### PROTECTION FROM OIL AND GREASE

- When handling oil or grease, always wear appropriate protective clothing and oil-resistant gloves.
- Avoid skin contact with oil and grease. This may cause skin injuries.
- Never use oil or lubricating grease to clean your skin. These substances may contain small metallic particles that cause wounds which are worsened by the oil.
- Follow the handling and safety instructions issued by the lubricant manufacturers.
- Synthetic oils are often corrosive and can cause severe irritation of the skin.

### WASTE OIL

- Collect the waste oil and dispose of it in accordance with national regulations.

### ACCIDENTS

- If oil is dispersed in the soil, prevent it from spreading and collect it, for example, by absorbing it with peat.
- If you have skin injuries caused by oil or a lubricant, consult a doctor immediately.

# 4 WARNING STICKERS, SAFETY COMPONENTS AND SERIAL NUMBER PLATE



BEWARE OF THE FEED ROLLERS

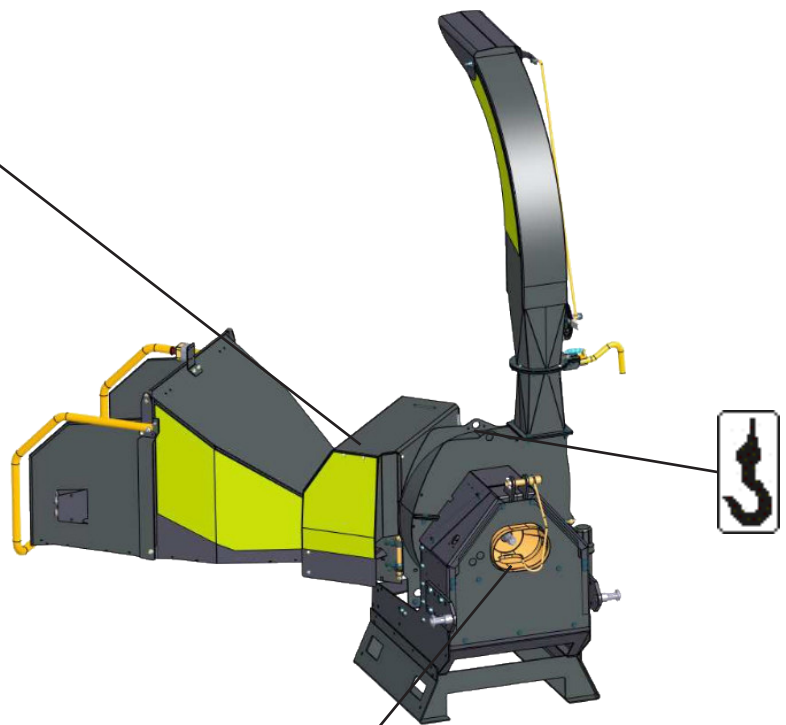

BEWARE OF THE DRIVE SHAFT



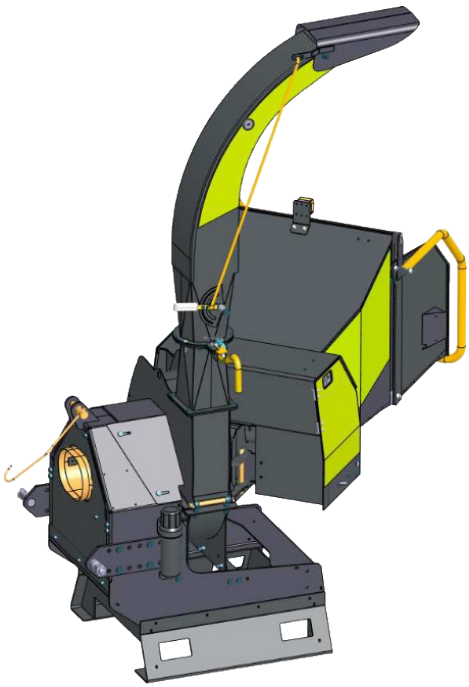

USE EAR PROTECTORS

BEWARE OF WOODCHIPS

SAFETY DISTANCE

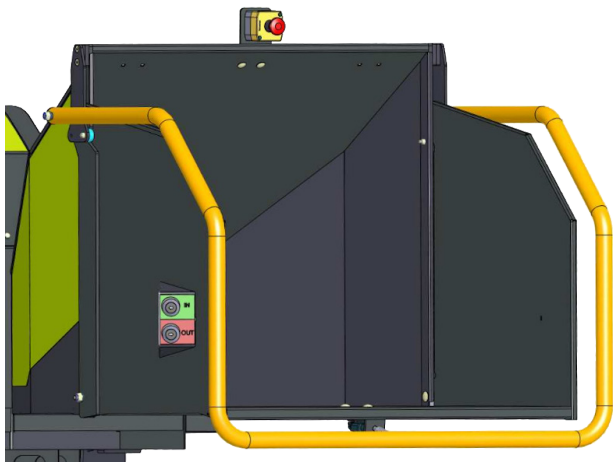

- Feed in with green "IN" button
- Stop feed with red "OUT" button and reverse feed by holding the button
- Yellow bar around the infeed chute and red button above the chute work as emergency stop

#### 4.1 SERIAL NUMBER PLATE



Serial number plate

1. Machine name
2. Machine type
3. Serial number
4. Machine weight without accessories
5. CE-label installation year



OPERATING INSTRUCTION  
AND SPARE PARTS MANUAL





## 5 OPERATING ENVIRONMENT

### 5.1 INTENDED USE

The purpose of a chipper is to produce chips from trees which are suitable to be fed into the chipper's feed orifice based on their diameter and other measurements. The wood material must be clean. Dust, sand or soil quickly wear down the blades. Metal objects, such as nails, will cause denting of the blades. Larger metal objects may damage the chipper.

For other types of use such as chipping down cardboard rolls, plastic piping or hard boarding panels, please contact your dealer.

### 5.2 LIMITATIONS OF USE AND PROHIBITED USES



Limitations regarding the machine operator

- The machine operator may not be under the influence of intoxicating substances, alcohol or strong medication.
- In cases of illness or permanent disability, the doctor in charge should be consulted for a permission to operate the machine.
- The use of the chipper is prohibited for persons without the sufficient level of knowledge and skill required to operate the machine and for persons under the age of 15.

Prohibited uses

- The chipper may not be used in nature reserve areas.
- The machine may not be used to spread liquids, inflammable materials, sand or fibrous material.
- Avoid using the machine in areas where its use could cause inconveniences in surrounding areas due to excessive noise or the spreading of dust.
- Chipping highly inflammable materials is strictly prohibited.

## 6 PRINCIPLE OF OPERATION

### 6.1 PRINCIPLE OF OPERATION

Junkkari woodchipper is always equipped with the feeding device. The feeding device feeds material to the knives by using feeding rollers. The feeding rollers are driven by the hydraulic motors and the rotating direction is operated with the hydraulic valve. The valve is controlled with the electrical buttons and circuit board.

The knives that are attached to the disc and cut the wood with a specific knife setting (see part 10.1). The wood chips are ejected through the knife openings to the blowing wings of the disc. The discharge chute directs the chip flow to the desired destination.

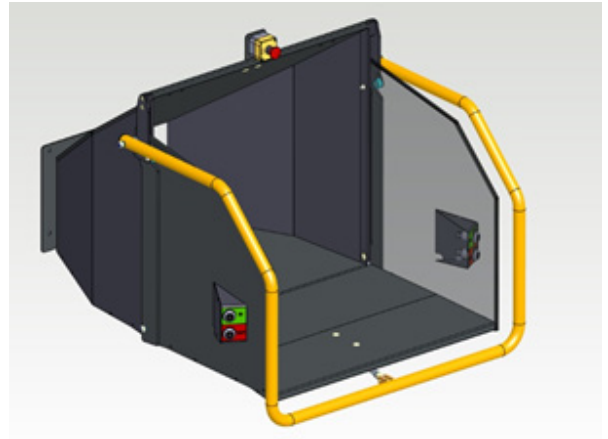

### 6.2 NO-STRESS FEATURE

In Junkkari woodchipper there is always a no-stress feature. Purpose is to prevent chocking which can happen with big hard materials when tractor is not oversized. The idea is to set the certain RPM level for the disc, and if RPM goes below that, the feeding will stop.

The chipper has the RPM sensor and the current RPM is shown on the display. The base value for no-stress limit is 300. This value can be modified by using the no-stress button next to the display. When pushed and hold for 5 seconds, the new no-stress limit is set to the RPM which you have at the moment. The RPM value goes quickly to " - - -", which indicates that the no-stress value is now set. Operating RPM should always be at least 10% over the no-stress level.

Example:

- Customer wants to chip wood with 800 RPM. He adjusts revs on the tractor so that chipper RPM is 700 and holds the no-stress button for 5 seconds. When 700 quickly turns to - - - value is set. The operator now increases revs on the tractor so that the RPM shows 800. Wood chipping can start.

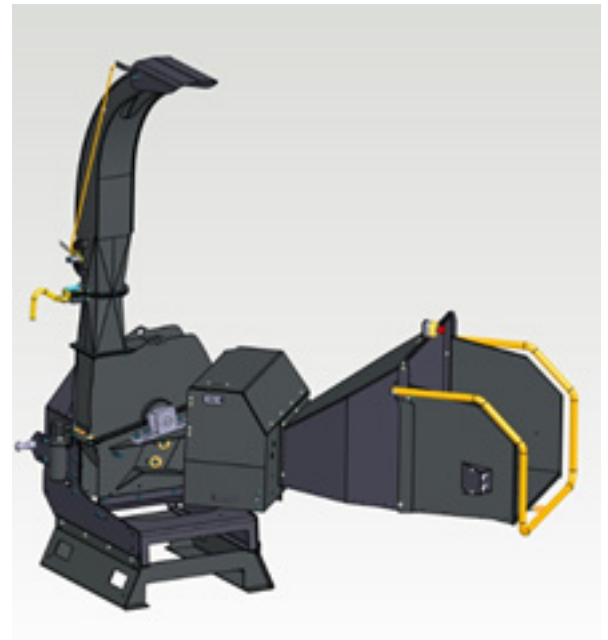

Crane feed chipper is controlled by Wizard C+ control unit. Instruction manual is delivered separately with the machine. Crane feed models don't have the safety devices which are needed in hand feed models. Therefore it's strictly forbidden to feed these chippers manually by hand. Safety distance in crane feed chipper is same as in the crane which is used for loading or minimum 20m.



## 7 TRANSPORTATION, HANDLING AND STORAGE

(IMPORTER, CENTRAL FIRM, DEALER)

### 7.1 TRANSPORTATION

- Terms of delivery are ex works unless otherwise mutually agreed.
- The purchaser (distributor) shall agree with the Manufacturer on the date upon which the product is ready for delivery at the factory.
- The Manufacturer shall ensure that the product is properly loaded onto the delivery vehicle.
- During transportation, all responsibility of the product shall lie with the handling agent.

### 7.2 HANDLING

- The product must be handled with the same care as most agricultural or forestry machinery in order to avoid amanging the product.
- No other products may be loaded on top of the product.
- The product is delivered well-packed from the factory.

### 7.3 STORAGE

- The machine should be stored in its normal working position and protected against sunlight and rain. When stored outdoors, the machine should be inspected from time to time for any rainwater accumulation on top.
- For longer periods, the machine should always be stored indoors.



### 7.4 SPECIAL SAFETY INSTRUCTIONS FOR MACHINE TRANSPORTATION

- The machine may only be lifted at the points indicated with instruction stickers.
- Ensure that the lifting device is safe, has sufficient capacity and that there is no risk of overturning or falling down involved.
- Only use approved straps or chains for lifting.
- The chipper must not be lifted with the forks of a fork lift truck; either straps or chains should be used at all times.
- Always check that the straps or chains are in good condition prior to lifting.
- When using a lifting crane, always check the lifting distance.
- The chipper must always be securely tied down to the platform for the duration of Transportation.

## 8 IMPLEMENTATION

### 8.1 PREPARATIONS PRIOR TO OPERATING

The customer shall prepare the chipper prior to operating. If the chipper is delivered with its discharge spout removed, the spout shall be mounted onto the machine.

When taking the chipper into use the customer should ensure that all the safety panels are in place, that no foreign materials are left in the feed orifice and that the disc rotates freely. Before connecting the machine to the tractor, the user should check the instruction manual sections on the universal drive shaft. The chipper shall be coupled to the tractor with the equipment described above.

### 8.2 PACKAGE DISPOSAL

The wooden and cardboard packaging materials may be disposed of by burning or by taking them to a landfill. The plastic bags and cords included in the packaging materials should be disposed of either by recycling them according to national regulations or by taking them to a landfill.

### 8.3 ATTACHMENT TO A TRACTOR

The chipper is suitable for tractors equipped with category 2 lower links (the diameter of the machine attachment pin is 28 mm)

The length of the mounting links can be adjusted by the holes in the links. The tractor mounting links and the top link are attached in the normal way, and the mounting links are secured in their central position by means of their stabiliser.

#### TRACTOR PTO

The chipper should be started carefully due to the large masses inside the chipper. During operation, the chipper rotational speed should be kept between 540 and 1,000 rpm. The universal drive shaft is discussed in the UNIVERSAL DRIVE SHAFT section.

#### HYDRAULICS

For its operation, the HJ 170 G/HJ 250G/HJ261G requires hydraulics from the tractor with a single control valve, fitted with single pressure and return connectors.

The required hydraulic system output is approx. five to twenty l/min depending on the blade setting selected, and the minimum pressure is 140 bar

#### INSTALLATION OF THE ELECTRICAL SYSTEM (accessory/loader infeed)

Install the remote control box in a suitable place inside the tractor cabin and the 15-pin socket in a suitable place on the rear wall outside the cabin. Connect the remote control box to the tractor's electrical system with a 12V plug. Connect the 15-pin plug from the chipper to the socket. The chipper's electrical system is now in working order. This can be tested e.g. by adjusting the spout discharge direction flap.

#### Remote control



#### 15 pin socket



#### Feeding device emergency stop button



## 9 UNIVERSAL DRIVE SHAFT

### UNIVERSAL DRIVE SHAFT TYPE HJ 172

#### Implementation

The universal drive shaft should have the capacity to transmit power at a rate of 50 kW at a nominal speed of 540 rpm and to sustain a torque of 900 Nm. The shaft should be fitted with an overrunning clutch and an overload clutch.

Suitable drive shaft types include e.g. EG 50 051 CE112 Rf2.

### UNIVERSAL DRIVE SHAFT TYPE HJ 252/HJ262

#### Implementation

The universal drive shaft should have the capacity to transmit power at a rate of 67 kW at a nominal speed of 540 rpm and to sustain a torque of 1 900 Nm. The shaft should be fitted with an overrunning clutch and an overload clutch.

Suitable drive shaft types include e.g. the Walterscheid W2400 SD25-610-FK96/4 195kpm/II.

### UNIVERSAL DRIVE SHAFT LENGTH

The drive shaft must be of correct length for operator safety, for the resistance of the shaft itself and its operation. The drive shaft tubes must overlap by at least 100 mm (10 cm). If the shaft is too long, it will bottom out, leading to drive shaft breakage. With a short shaft, the tubes may be separated from each other when the machine is lifted. This involves a significant risk of damage. Too small an overlap also prevents the shaft from transmitting the required power without being damaged.

### SHORTENING A UNIVERSAL DRIVE SHAFT

1. Determine the shortest length of the shaft by lifting the machine (Figure 1).
2. Leave a 25 mm margin on the shaft and mark the cutting points (Figure 2).
3. Cut off equal pieces of all four shaft tubes (Figure 3).
4. Remove cutting burrs with a file and clean all tubes.
5. Finish by greasing the shaft tubes thoroughly.

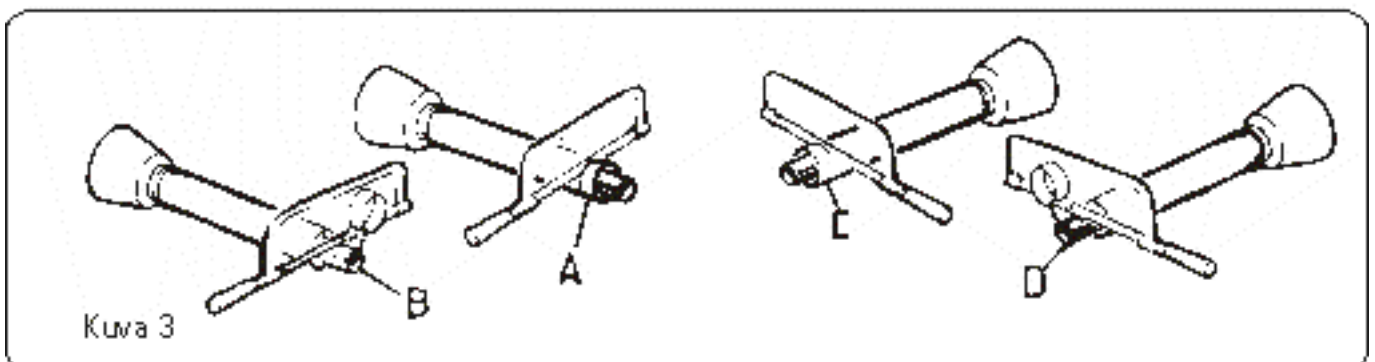
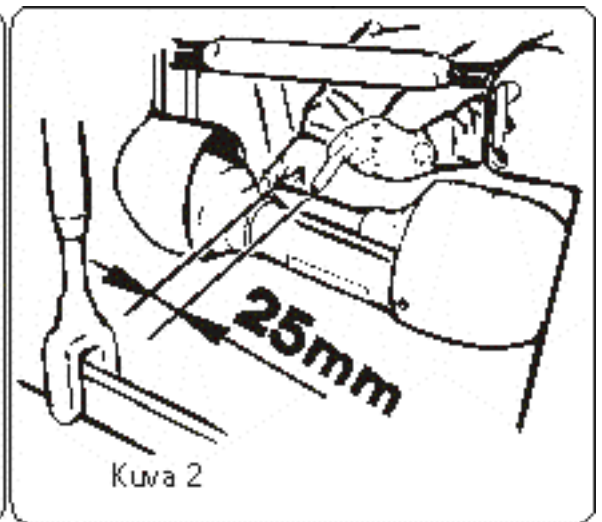
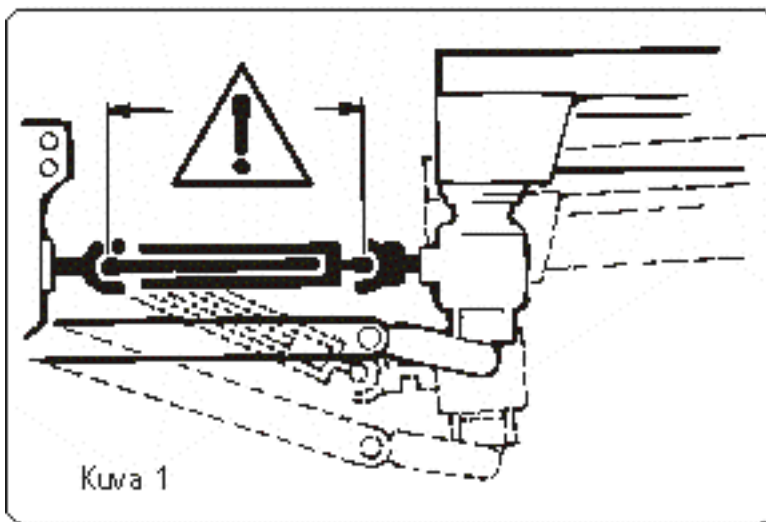

## 10 ADJUSTMENTS

PLEASE READ THESE INSTRUCTIONS CAREFULLY AS THE CONDITION OF THE BLADES AND THEIR CORRECT ADJUSTMENT ARE CRITICAL TO THE OPERATION OF THE CHIPPER.

### 10.1 BLADE SETTING ADJUSTMENT

The blade setting (A) may be adjusted within the range of 3 to 15 mm. The smaller the blade setting, the smaller the chips the chipper produces. On the other hand, the blade setting affects the wood intake speed: a larger knife setting results in a faster and better wood intake.

Adjustment:

1. Loosen the blade retaining screws (3 pcs/blade) and the blade locking screws (2 pcs/blade).
2. Open the counter blade retaining screws and pull the counter blade out towards the feed chute.
3. Move one cutting blade to a desired distance from the blade disc. Tighten both the retaining and locking screws of the blade in question.
4. Move the counter blades to a distance of 1 mm from the cutting blade. Then secure the counter blades.
5. Proceed to adjust the remaining three cutting blades with the aid of the counter blade, leaving a 1 mm clearance in each cutting blade.
6. Finally, tighten all blade and counter blade retaining screws (200 Nm). Rotate the disc by hand to ensure that the cutting blades do not touch the counter blades and that the blade clearance (B) is correct (1 mm) and identical for each cutting blade.
7. Tighten the cutting blade locking screws to 30 Nm against the rear edge of the blades.

A=(3)5 -15(18) mm  
B=1mm  
C= 30.5°

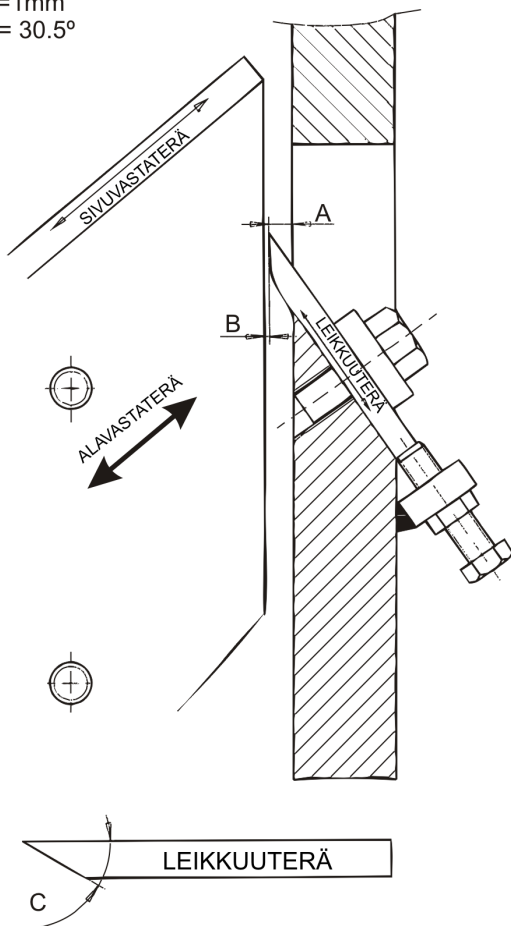

STICK BLADE (accessory) mounted on a standard blade.

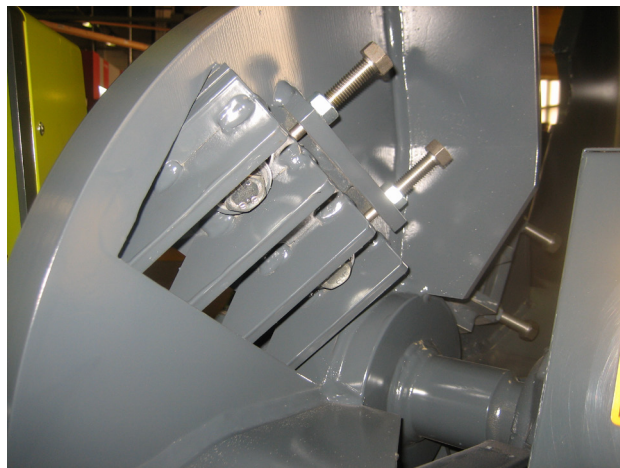

(Number of blades varies between models.)



## 10.2 FEEDING DEVICE SPEED ADJUSTMENT

The rotational speed of the feed rollers in G/GT/GTC models chippers must be synchronised with the cutting speed of the blades. If the feed roller rotational speed is too high in relation to the blade cutting speed, the feed rollers will dig into the stems that are fed in the machine. If the feed roller speed is too low in relation to the blade cutting speed, the feed becomes jerky.

The adjustment is started with a low feed roller rotational speed. At this stage, the cutting blades tend to pull wood out between the feeding machine rollers. The feeding device rotational speed is then slowly increased, until it is synchronised with the cutting blade setting of the disc.

### ADJUSTMENT

To adjust the feeding device speed, turn the adjusting wheel against the bottom. When wood is fed into the chipper, any variation between the speed of the feeding device and the blade disc can be observed. Then adjust by turning the adjusting wheel towards the fast end of the range. Repeat the adjustment where necessary.

### G/GT/GTC

ADJUSTING WHEELS





## 11 OPERATION

The material to be chipped should be pre-treated where necessary. Large tree branches, roots and boughs should be removed to fit the wood into the feeding orifice. It is recommended that the wood be placed near the chipper to avoid carrying it long distances. In this case, the work can be done as efficiently as possible, and the continuous flow of material will produce chips of the best quality.

## 12 MAINTENANCE

### READ THE SAFETY INSTRUCTIONS



#### MAINTENANCE AND REPAIRS

1. Always ensure that the PTO is disengaged and that the engine is stopped before carrying out cleaning, lubrication, assembly or adjustment work. Remove the ignition key to prevent the tractor or the machinery from starting up accidentally.
2. Secure the machine appropriately before carrying out maintenance work.

### 12.1 SHARPENING THE CUTTING BLADES

The cutting angle (C) of cutting blades delivered from the factory is 30.5 degrees. Blades should always be sharpened to this angle. A smaller sharpening angle will result in chipped blades, whereas a larger angle will reduce the blade clearance angle, reducing in turn the blades' ability to draw in the wood.

Please note that the cutting blades must not heat up during the sharpening process as the heat will cause the blades to lose their hardness. This is why the blades should be sharpened by grinding. Care should also be taken to sharpen all blades equally to ensure the balance of the blade disc.

Counter blades generally require no sharpening. Counter blades may, however, be rounded off if substances harder than wood (nails, sand etc.) enter the chipper. In this case, counter blades may be straightened by grinding e.g. with a bobbing machine. However, counter blades generally require no maintenance.

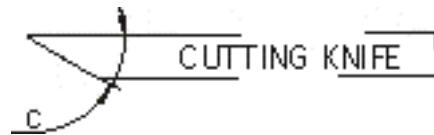

DISC SAFETY LOCK

The chippers are fitted with a standard safety lock for locking the disc while carrying out maintenance work on the blades.

### 12.2 LUBRICATION

Disc shaft bearings (2 pcs):

The outer shell of the bearing will be removed and filled with Vaseline 50 h

Feeding device bearings (2 pcs): 50 h

Hydraulics (172GT/ 252GT/ 252GTC/ 262 GT/ 262GTC)

First oil change	10 h
Subsequent changes	200 h
First filter change	10 h
Subsequent changes	200 h
Oil type:	MOBIL DTE 13 or similar
Capacity:	28 L

## 13 TROUBLESHOOTING CHART

FAULT	CAUSE	REMEDY
The chipper does not draw in wood	Dull blades. Incorrect sharpening angle. Blade fitted the wrong way.	Sharpen and refit blades as per manual instructions.
Uneven chip size.	Blade clearance (B) is too large. Single strips of woods turn sideways after passing the feed rollers.	Adjust blade clearance as per manual instructions. Feed wood continuously.
The discharge spout is blocked	Rotational speed too low.	Increase the rotational speed to 540-1000 rpm.
Power requirement is excessive in relation to the power device.	Power device is too small. Blade settings is too large (A).	Reduce the blade setting or remove the opposite blades.
The feed rollers are weak (Model G).	Not enough oil.	Increase the amount of hydraulic oil.
The feed rollers are not rotating (in winter) (model G).	The oil tank contains too much water.	Defrost, drain water.
Ingoing wood produces vibrations.	The feed rolls are not properly synchronised.	See the synchronisation instructions.

The normal wear of the chipper is safe and will cause no danger. In practice, the blades are the only chipper parts subject to wear. Should the bearings exhibit end play, they should be adjusted by an expert.



PLEASE NOTE THAT THE MACHINE IS INTENDED TO BE USED BY A COMPETENT OPERATOR. THIS IS WHY ITS USE REQUIRES A SUFFICIENT LEVEL OF GENERAL KNOWLEDGE AND SKILL.



## 14 WITHDRAWAL FROM SERVICE

### **READ THE SAFETY INSTRUCTIONS**



Withdrawing the product from service is the responsibility of the product's end user or the person or company who owns the product at the time the decision has to be made. The disposal of the machine and the management of the various resulting waste materials are governed in all countries by national laws, instructions and regulations which are to be complied with. Most chipper components are made of non-biodegradable materials. This is why the chipper should be disassembled and the materials should be disposed of according to national regulations.

- Steel and other metallic parts will be recycled via scrap yards or stripping yards.
- Waste oil, plastic and rubber components (other than tyres) will be disposed of as hazardous waste by recycling, taking them to a landfill or by other means compliant with national regulations.

Where necessary, environmental authorities will provide further information on the disassembly process and on waste management.

## 15 TERMS OF WARRANTY

1. The warranty period is 24 months provided that the machine is used for its intended agricultural purposes.
2. In municipal, industrial or professional contract work or similar uses, the warranty period is six months.
3. The warranty period starts from the date of delivery by an authorized dealer.
4. The warranty will cover manufacturing and material defects. Damaged parts will be repaired or exchanged for parts in full working order at the factory or at an authorised repair workshop. Subcontracted components are covered by the warranty policies of their manufacturers.
5. Repairs carried out within the warranty period will not extend the warranty period.
6. The warranty will not cover damage caused by incorrect use contrary to the practices laid out in this manual, incorrect maintenance, excessive loading or normal wear. Furthermore, the warranty will not cover subsequent damage, down-time, travel expenses, freight charges, daily allowances, overtime expenses or cases in which the original machine design has been modified.

In warranty matters, please contact your local dealer who will prepare a warranty claim.

Repair work and the potential costs must be agreed on with the manufacturer before any repair work is carried out.

The warranty shall be valid only if a warranty registration card is filled in and returned to the Manufacturer within fourteen days of the product's delivery date.

## 16 LIABILITY

The manufacturer shall not be responsible for any damages arising from the use of the machine in any manner contrary to law, safety regulations or the instructions laid out in this manual. As situations unforeseen in the instructions or regulations may arise during the use of the machine, the operators are advised to act according to general safety regulations and directives relating to machinery.

The manufacturer shall not be liable for damages arising from the use of components produced by other manufacturers. The manufacturer shall bear no responsibility for damages caused by the chipper to other machines or devices. The manufacturer reserves the right to make changes to the product.

The owner of the machine shall be responsible for operating, maintaining and servicing the machine, unless otherwise agreed.

The owner of the machine shall be responsible for ensuring that all persons operating the machine receive sufficient information on the handling and use of the machine.

## 17 ASSURANCE OF COMPLIANCE WITH EC REGULATIONS

### ASSURANCE OF COMPLIANCE WITH EC REGULATIONS

Junkkari Oy  
Pohjanmaanväylä 1661  
FI-62375 Ylihärmä, Finland

Here with declare on our sole responsibility that for the market produced machine

HJ172 from the manufacturing number HJ172100102

HJ252 from the manufacturing number HJ252100101

HJ262 from the manufacturing number HJ262100101

is manufactured, where applicable, in conformity with provisions of the instructions of the normative document according to the following directive: 2006/42/EY.

JUNKKARI OY  
Kauhava 30.10.2019



Jan Tapanainen  
Managing director

Tarmo Kukkola is authorized to collect the technical construction file of the machine.

Tarmo Kukkola  
R&D Manager  
Junkkari Oy, Pohjanmaanväylä 1661, 62375 Ylihärmä, Finland  
Tel +358 (0)10 480 2534  
Mob +358 442 898 979  
tarmo.kukkola@msk.fi  
www.junkkari.fi

ORIGINAL





Junkkari  
Part of the MSK Group

A GOOD WAY TO  
**WORK  
HARD**