

Junkkari

TRACTOR TRAILER

J-10

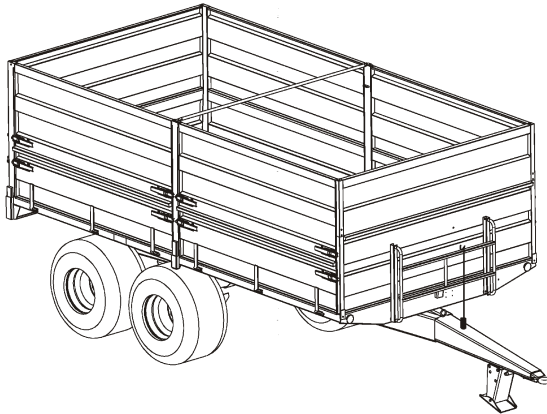

J-10D

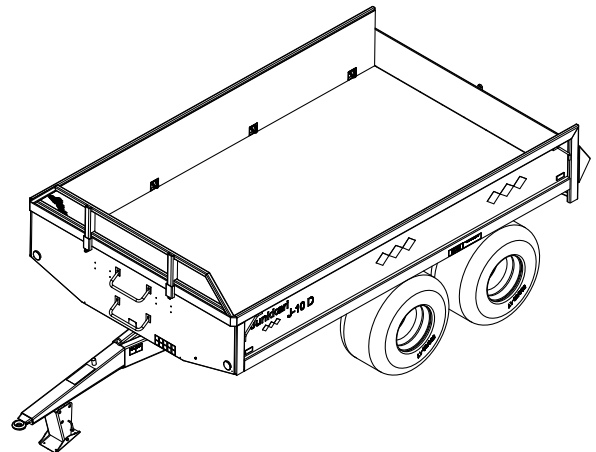

USER GUIDE SPARE PART LIST

J10-16EN

Junkkari Oy
62375 YLIHÄRMÄ FINLAND
TEL. +358-(0)10-4802200
FAX +358-(0)10-4802295
e-mail: junkkari@msk.fi
Internet: www.junkkari.fi

ENGLISH 

1 TABLE OF CONTENTS

	PAGE
2	INTRODUCTION..... 3
3	TECHNICAL SPECIFICATIONS..... 3
4	SAFETY INSTRUCTIONS..... 4
4.1	GENERAL SAFETY INSTRUCTIONS..... 4
4.2	SPECIFIC SAFETY INSTRUCTIONS FOR TIPPER TRAILERS..... 4
4.3	TRANSPORT AND MOVING..... 5
4.4	HYDRAULICS..... 5
4.5	SERVICE AND REPAIRS..... 6
5	SAFETY LABELS AND COMPONENTS AND THE TYPE PLATE..... 6
5.1	SAFETY MARKINGS..... 6
5.2	LIGHTS AND SLOW VEHICLE SIGN..... 10
5.3	BRAKES..... 10
5.4	TYPE PLATE..... 11
6	OPERATING ENVIRONMENT..... 12
6.1	PURPOSE OF USE..... 12
6.2	APPLICATION..... 12
6.3	USE RESTRICTIONS AND PROHIBITED FORMS OF USE 12
7	FUNCTIONING PRINCIPLE..... 12
8	TRANSPORTING, HANDLING AND STORING THE MACHINE..... 13
8.1	TRANSPORTING..... 13
8.2	HANDLING..... 13
8.3	STORING..... 13
8.4	SPECIAL SAFETY INSTRUCTIONS FOR TRANSPORTING THE MACHINE..... 13
9	PUTTING TO USE..... 14
9.1	CONTENTS OF THE PACKAGE..... 14
9.2	DISCARDING THE PACKAGING..... 14
9.3	ASSEMBLY..... 14
9.3.1	INSTALLATION INSTRUCTION FOR BASIC SIDE PLATES..... 15
9.3.2	INSTALLATION INSTRUCTION FOR GRAIN SIDE PLATES..... 16
9.3.3	REAR PLATE LOCKING AND SEALING..... 17
9.4	ASSEMBLY OF THE ACCESSORIES..... 17
9.5	ATTACHING TO A TRACTOR..... 18
10	CHECKS..... 21
11	LOADING..... 22
12	USE..... 22
12.1	NORMAL TIPPING..... 22
12.2	LOWERING THE PLATFORM..... 22
13	SERVICE..... 23
13.1	LUBRICATION DIAGRAM..... 23
13.2	HYDRAULICS MAINTENANCE..... 24
13.3	ADJUSTING THE BRAKES 24
13.4	ADJUSTING AND TIGHTENING THE HUB..... 24
14	TROUBLESHOOTING DIAGRAM..... 25
15	WITHDRAWING THE PRODUCT FROM USE..... 26
16	TERMS OF WARRANTY..... 27
17	RESPONSIBILITY AREAS..... 27
	DECLARATION OF CONFORMANCE TO EU REGULATIONS
	SPARE PART LIST



Warning sign

The manual always uses this sign to indicate danger to the user or others. This sign is also used to indicate danger to the environment or property.

2 INTRODUCTION

We thank you for your trust and wish you the best success with your work. We ask that you familiarize yourself with this user guide, to completely understand the machine, its correct adjustments, and careful maintenance. This will guarantee user safety and continuous machine operation on busy workdays. It is important to understand and follow the instructions of every section in this guide. Please contact the seller of this machine with any questions. We recommend returning the signed warranty card to the factory after reading the user guide.

3 TECHNICAL SPECIFICATIONS

		J-10	J-10D
CARRYING	Kg	10000	10000
CAPACITY TYRE		400X15.5/14	400X15.5/14
PLATFORM SIZE	cm	240x420	242,5X415
VOLUME WITH BASIC SIDE PLATES	m ³	5,0	6,0
VOLUME WITH GRAIN SIDE PLATES	m ³	13,1	13,1
WITH ADDITIONAL GRAIN SIDE PLATES	m ³	16,1	
TIPPING ANGLE	1°	52	52
TIPPING CYLINDERS/PIPES	pcs	1/3	1/3
CYLINDER OIL NEED	L	8,3	8,3
PLATFORM H. FROM THE GROUND	cm	104	104
GAUGE	cm	185	185
WEIGHT WITH GRAIN SIDE PLATES	KG	1830	2810
PARKING BLOCK	pcs	*2	*2

OPTIONAL ACCESSORIES:

TYRES 500/50-17

ACCESSORIES:

BRAKES	yes
FRESH FODDER EQUIPMENT (J-10)	yes
ADDITIONAL SIDE PLATES FOR GRAIN SIDE PLATES (J-10)	yes
PRESSURE REGULATION VALVE FOR BRAKES D56010 120bar	yes
GRAIN PLATES CASSETTE (J-10D)	yes

*) Only in model for Norway

SPEED	TYRES	ALLOWED LOAD
40 km/h	400/60-15.5	10000 kg

CONTENTS OF THE SUPPLIES PACKAGE (J-10):

	Pcs	part number
Inside step	2	1107120
Outside step	1	26125
Basic plates	4+1+1	
Grain plates	4+1+1	
Poles for grain plates	1+1+2	24114, 24138, 24112
Poles for basic plates	1+1+2	24149, 24152, 24147
Intermediate bar	1	26121
Hatch in the basic rear plate	1	1785319
Hydraulics hose support	1	D14111
Rear plate opening lever	1	29236
Instuction manual	1	

4 SAFETY INSTRUCTIONS



4.1 GENERAL SAFETY INSTRUCTIONS

- CLOTHING: For your own safety, wear well-fitting clothes with no loose sections.
- USE: Before using the trailer, familiarize yourself with its connection, controls, and overall operation.
- WARNINGS: Follow all warnings and instructions attached to the trailer.
- GUARD PANELS: The trailer can be used only when all the guard panels are in place and in good condition.
- CONNECTING TO A TRACTOR: Use caution when connecting or disconnecting the trailer.
- LOADING THE PULLING DEVICE: Take into consideration the maximum capacity allowed for loads when using the drawbar and tractor.
- PARKING: Make sure the trailer is properly secured when in the parked position.
- SAFETY DISTANCE: Because of its operating principle, the trailer includes parts that are not fully protected. You must keep a sufficient distance from these parts at all times. The operator must also make sure that bystanders stay clear of these parts.
- WORKING WITH THE TRAILER: When working with the trailer, it is forbidden to be in the near vicinity.
 1. Check the fastening of a new trailer's parts and that all parts rotate freely.
 2. Trailer cleaning, lubrication or adjustments must not take place when the power output and hydraulics of the trailer are connected.
 3. Before starting your work, you must make sure that no one is under or behind the trailer, or on its platform.
 4. Before exiting the control cabin set the gear on neutral and engage the parking brake.
 5. Do not let children or extra passengers in the cabin during use.
 6. Check the tightness of the wheel bolts after the first three hours of driving.

4.2 SPECIFIC SAFETY INSTRUCTIONS FOR TIPPER TRAILERS

1. The tipping direction of the platform must be selected so that the trailer's side is facing the tipping site and the trailer is horizontal.
2. The manufacturer is not responsible for any damage caused by overloading the trailer.
3. The support of the drawbar must be in the upper position during driving.
4. Remember to keep the hydraulics use lever in the emptying position long enough to release the pressure from all use targets.
5. Being under a tipped platform or the frame is prohibited, unless they are supported.
6. Vaulting the material to be transported can cause a danger of tipping over.
7. When the side plates are turned down, tipping is absolutely forbidden.
8. Service support is meant only to support an empty platform.
9. Make sure that the tipper hydraulics is pressure-free when you use the service support and that the platform rests well on the service support.

4.3 TRANSPORTING AND MOVING



- Always follow traffic rules and regulations when driving on general roads.
- Before using the trailer, make sure that the brake system is connected and that it works properly.
- Inspect and install all necessary accessories needed to travel on general roads, such as lights, reflectors and slow vehicle warning sign.
- Take into consideration the allowed axle weights, total weights and transport measurements.
- When using maximum load, the trailer's allowed maximum driving speed is 40 km/h.
- When using the shredder frame, make sure that the drawbar locking is secured and that the trailer has been moved to travel in line with the tractor.
- It is important that you always follow the allowed axle and shaft weights, as the trailer load will affect the behaviour of the tractor during transport, how the tractor can be directed, and how the brakes function.
- Passengers may not be transported in the trailer
- The trailer can be lifted only from the places marked with instructions labels.
- Use only approved lifting straps or chains. Please check their condition before using.
- When transporting a trailer, it must be tied securely to the platform with chains or straps.
- When loading (e.g. with a forklift), you must make sure that the trailer is balanced and in no danger of dropping.

4.4 HYDRAULICS

- Connecting the hydraulics system causes high pressure to occur. Hydraulics oil bursting out with high pressure will permeate skin and may cause serious injury. A risk of injury exists also when leak points are searched for.
- Be careful with all hydraulics parts, as there is a danger of being pressed and cut by these parts.
- The hydraulics connectors must not be removed when the machine is on hydraulics only, because then pressure will remain in the system.
- When connecting the hydraulics hose to the tractor, the hydraulics must not be pressurised from the machine or tractor side.
- Do not exceed the hydraulics oil maximum pressure of 210 bar.

PROTECTING FROM OILS AND GREASES

- When handling oil or grease, always use appropriate protective clothing and oil-proof gloves.
- Avoid skin exposure to oil and grease. The skin may be damaged.
- Never use oil or lubrication grease to clean the skin! These substances may contain small metal fragments that cause cuts to hands and the oil will make the cuts worse.
- Follow the handling instructions and safety regulations of the lubricant manufacturers.
- Synthetic oils are often corrosive and cause strong skin irritation.

WASTE OIL

- Waste oil must be collected and disposed of according to national regulations.

ACCIDENTS

- If oil enters the soil, you must stop it from spreading and collect it (e.g. by absorbing it to peat).
- If oil or lubricant cause skin injuries, contact a physician immediately.

4.5 SERVICE AND REPAIRS



- Before doing any cleaning, lubrication, installation or adjustment work, always make sure that power take-off is disabled and that the engine is stopped. Remove the ignition key to prevent inadvertent start of the tractor or machine.
- The trailer must be properly supported before starting service.
- When working under a lifted tipper platform you must absolutely support the platform with the service support.

5 SAFETY LABELS AND COMPONENTS AND THE TYPE PLATE



5.1 SAFETY MARKINGS



Danger of being pressed



Front reflectors Side reflectors

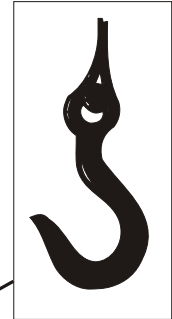

Machine lifting point



Danger of being pressed

Do not go under an unsupported platform

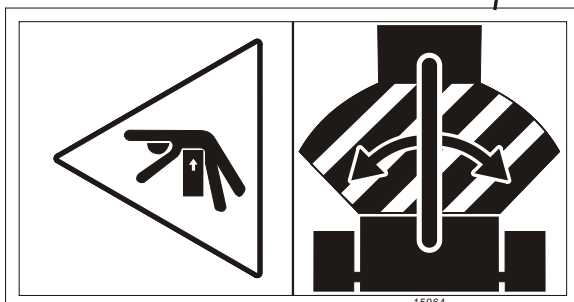

Danger of being pressed between the machine and tractor

WARNING

Do not go under the tipped platform when it is unsupported. The platform support is meant only for supporting an empty platform

VARNING

LUTA ER EJ IN UNDER UPPTÄPPAT FLAK UTAN ATT DETTA ÄR SPÄRRAT DIMENSIONERAT ENDAST FÖR TOMT FLAK

4-9226

Tyre pressure

Mitas
Mitas
Nokian
Nokian

400/60-15.5	14ply	350 kPa
500/50 -17	14ply	350 kPa
560/45 R22.5	146D	320 kPa
600/50 R22.5	156D	360 kPa

HUOM ! Kiristä pultit 3 tunnin ajon jälkeen.
OBS ! Spänn bultarna efter 3 h körning.
NOTE ! Tighten the bolts after 3 operating hours

38070



Machine lifting point

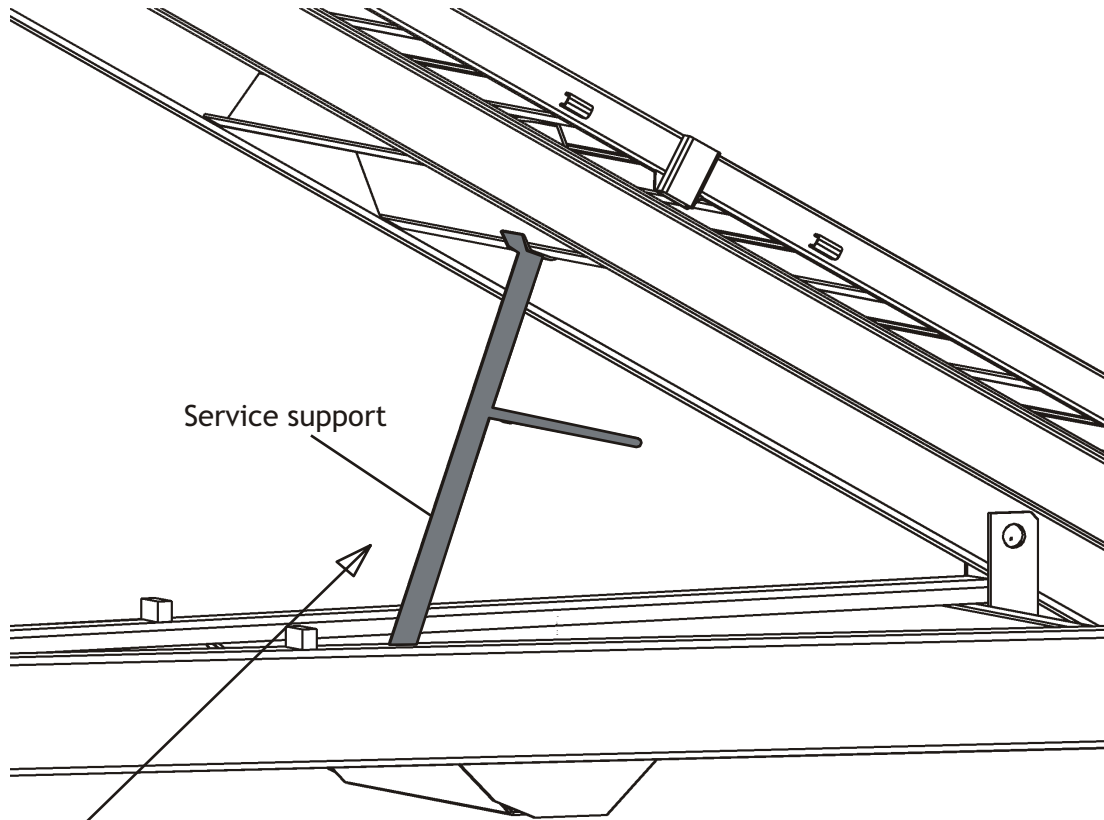

ALWAYS USE SERVICE SUPPORT WHEN WORKING UNDER A LIFTED PLATFORM
NOTE! SERVICE SUPPORT IS MEAN ONLY TO SUPPORT AN EMPTY PLATFORM.

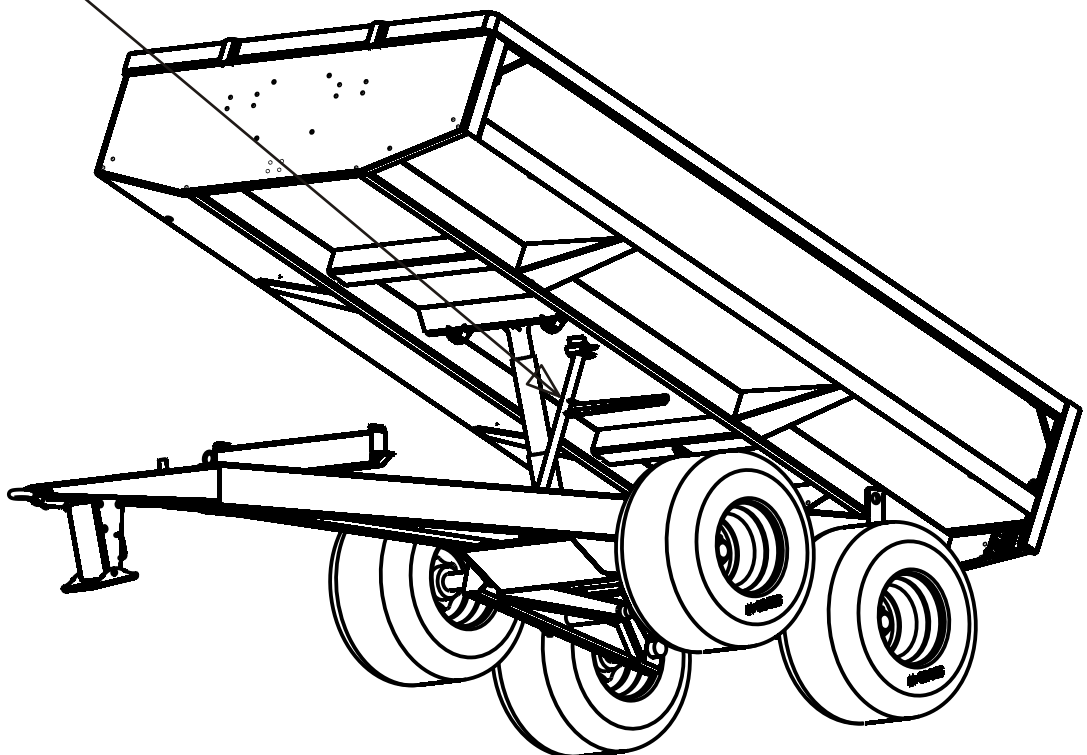

5.2 LIGHTS AND SLOW VEHICLE SIGN



THE JUNKKARI TIPPER TRAILER BY DEFAULT INCLUDES LIGHT AND REFLECTOR DEVICES ACCORDING TO EU DIRECTIVES. THESE FUNCTION THROUGH THE TRACTOR 7-POLE PLUG. LIGHTS MUST BE USED ALWAYS WHEN DRIVING ON GENERAL ROADS.

ONE SLOW VEHICLE SIGN IS AT THE BACK OF THE MACHINE

REAR LIGHTS, INDICATORS AND BRAKE LIGHTS

THERE ARE TWO YELLOW REFLECTORS ON BOTH SIDES.



5.3 BRAKES

The Junkkari J10 trailer can be equipped with brakes powered by the brake valve installed in the tractor. The quick coupling in the trailer is equipped with a connector according to SFS 4946 standard.

Brakes must be used always when the national legislation so requires.

More information about brake use is on page 20.

ACCESSORY:

If it is not possible to install the brake valve in the tractor, a special pressure reduction valve can be installed in the brake hose (maximum pressure = 120 bar).

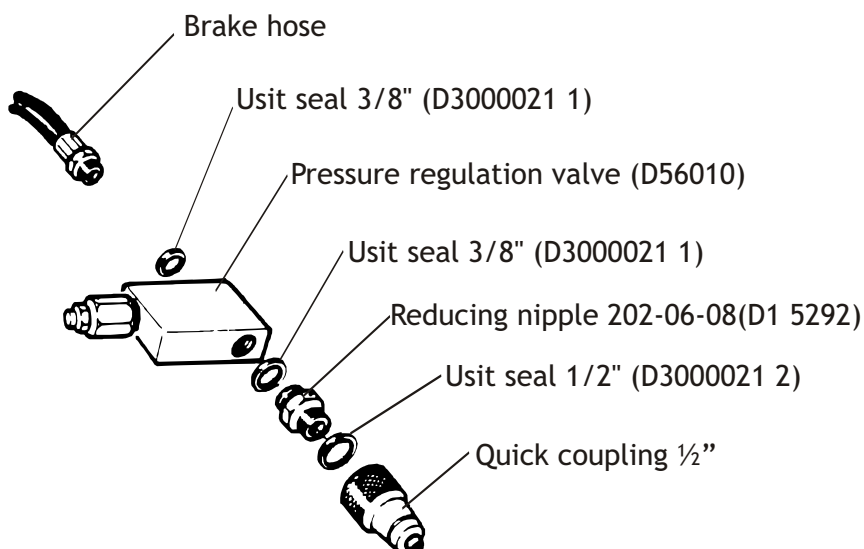

5.4 TYPE PLATE

Malli	<input type="text"/>	Type
Valm.n:o	<input type="text"/>	Mfg n:o
Valm.vuosi	<input type="text"/>	Year
Renkaat	<input type="text"/>	Tyres
Kantavuus	<input type="text"/>	Carr. cap
Kok. paino	<input type="text"/>	Total weight
Aks. paino	<input type="text"/>	Axle weight
Max.aisapaino	<input type="text"/>	Max.boomload
 JUNKKARI OY 62375 YLIHÄRMÄ FINLAND		



6 OPERATING ENVIRONMENT

6.1 PURPOSE OF USE

Junkkari tipper trailers are meant for transporting bulk goods and parcelled goods. The trailer can be used as a tipper trailer to transport soil and other materials, taking into consideration the set carrying capacity, recommendations and safety instructions. The grain platform provides full payload for transporting grain.

6.2 APPLICATION

The grain platform can be equipped with additional fresh fodder side plates, so the trailer can be used effectively in transporting fresh fodder.

6.3 USE RESTRICTIONS AND PROHIBITED FORMS OF USE

Limitations for user

- The user must not be under the influence of drugs, alcohol or strong medicine.
- In sickness or disability cases, permission to use the device can be given by the treating physician.
- The use of the device is prohibited for all persons that lack appropriate information and skills of agriculture and for anyone fewer than 15 years of age.

Prohibited forms of use

- Any material that may corrode or erode may not be left in the trailer for an extended period of time.
- The tipper trailer must not be used in any instances where the trailer will tip over.
- Transporting people and animals or lifting them with the tipper trailer is prohibited.
- Transporting unfastened big bales is prohibited.

7 FUNCTIONING PRINCIPLE

The tipper trailer is meant to be connected at the rear end of the tractor. The tipper trailer can be used to move and unload different solid materials and parcelled goods. The tipper of the grain trailer works with the help of the tractor hydraulics.

8 TRANSPORTING, HANDLING AND STORING THE MACHINE

(IMPORTER, CENTRAL FIRM AND RE-SELLER)

8.1 TRANSPORTING

1. The delivery term of the device is ex works, unless otherwise agreed.
2. The buyer (central firm) agrees with the manufacturer regarding the time the product is ready for pick up.
3. The manufacturer is responsible for loading the product.
4. The transport company is responsible for the product during its transport.

8.2 HANDLING

1. The product must be handled as a standard agricultural machine, carefully and without damage.
2. No other products can be loaded on the product.
3. The product is sent from the factory carefully packaged.

8.3 STORING

1. The trailer must be stored protectively from sunlight and rain.
2. When storing outside, you must check periodically that no water remains in the trailer.
3. More long-term storage should always take place indoors.
4. The trailer must be stored with the tipper in the lower position, to avoid rusting on the tipping cylinder pipes.

8.4 SPECIAL SAFETY INSTRUCTIONS FOR TRANSPORTING THE MACHINE



1. The machine can be lifted only from the places marked with instructions labels.
2. Make sure the lifting device is sufficient and that there is no danger of tipping over or falling.
3. It is prohibited to lift the machine with the forks of a forklift; you must always use either straps or chains. ~ Use only approved straps or chains.
4. Before lifting, always make sure the straps and chains are in good condition.
5. When lifting the machine, the straps or chains must be kept tight, so that the machine cannot swing and cause a danger.
6. Always check the lifting distance when using the lifts.
7. For the duration of transport, the machine must be tied to the platform.

9 PUTTING TO USE

The customer is responsible for putting the trailer into use, unless otherwise agreed when purchased.

READ SAFETY INSTRUCTIONS



9.1 CONTENTS OF THE PACKAGE

The package includes a basic trailer, which makes one container. The instruction manual is attached at the front of the trailer under the platform. The side plates are in their own packaging.

9.2 DISCARDING THE PACKAGING

The wooden and cardboard packaging material can be discarded by burning or by taking them to a dumpyard. The plastic bags and straps included in the packaging should be disposed of according to national regulations, by recycling or by taking them to the dump yard. Metal packaging materials should be taken to an iron collection point or to the dump yard.

Metal packaging materials should be taken either to iron collection point or to the dump yard.

9.3 ASSEMBLY

Tipper trailer:

The trailer is delivered with side plates removed, packed on a platform. The side plates can be installed easily. See the side plate installation instruction later on.



9.3.1 INSTALLATION INSTRUCTION FOR BASIC SIDE PLATE

Unpack the materials.

Install the basic front side plate. It can be recognised from two fastening ear which will be attached to front corners of the platform with screws. The side plate is 75cm high.

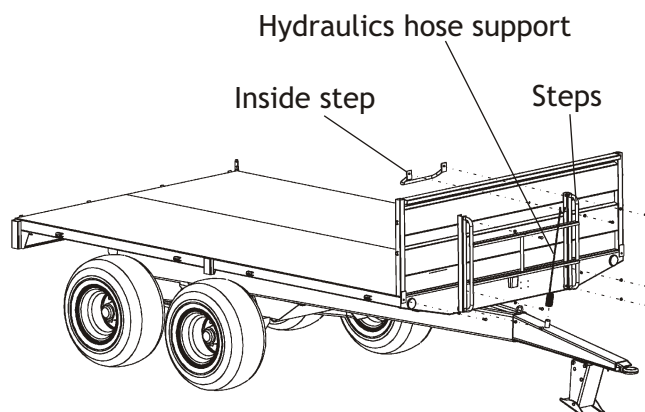
Attach the steps to the basic front side plate with screws. The separate step is meant for the inside. Install the steps opposite to each other sloping downwards. Install the hydraulics hose support to the peg in the drawbar by rotating the spring spiral in the support to the opposite direction.



	M10 x 25	9 pcs
	M10 IL	9 pcs

Install the corner and middle poles of the basic side plates.

Install the 50 cm high basic side plates into the sides of the trailer by pushing the hinge pegs into the hinge sleeves in the platform.

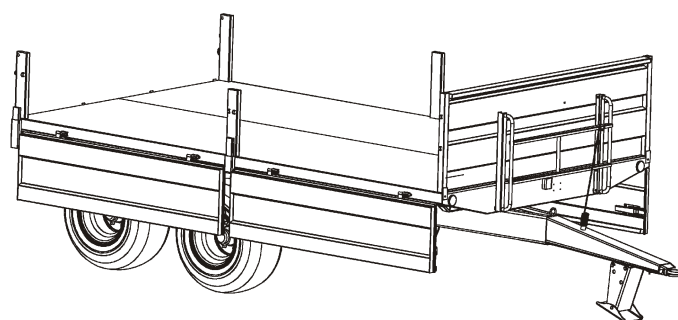

Install the basic rear plate and lift the basic side plates up.

The included loose axle pegs are used with the basic side plates. Push the pegs through the holes in the rear plate upper corners and rear poles and secure them with a ring cotter.

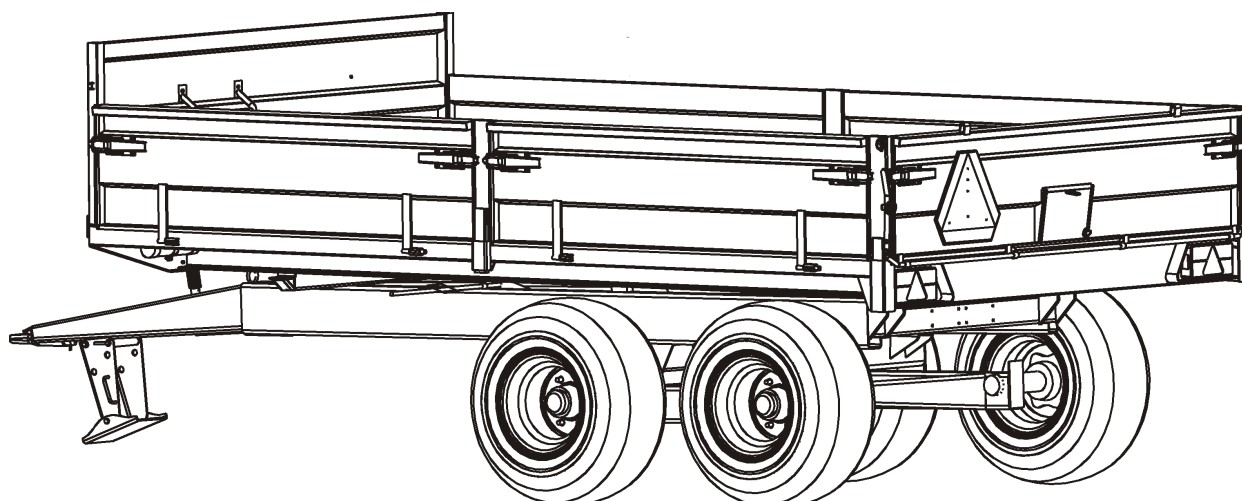

9.3.2 INSTALLATION INSTRUCTION FOR GRAIN SIDE PLATES

Unpack the materials.

Install the basic front side plate. It can be recognized from two fastening ear which will be attached to front corners of the platform with screws. The side plate is 75cm high.

Screw the steps to the front side plate with screws. The separate step is meant for the inside. Install the steps opposite of each other, slanting downwards. Install the hydraulics hose support to the peg in the drawbar by turning the spring spiral to the opposite direction in the support.

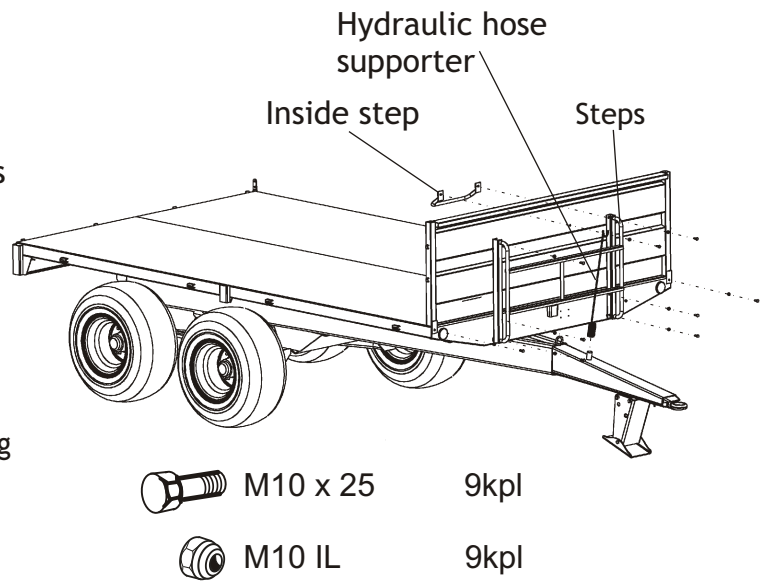

Install the grain side plate corner and middle poles as well as the 55 cm high front grain side plate. Stand on the platform when lifting the side plate to its place. The 50 cm high basic grain side plates are installed in the trailer from the side by pushing the hinge pegs to hinge sleeves. Don't close the side plates.

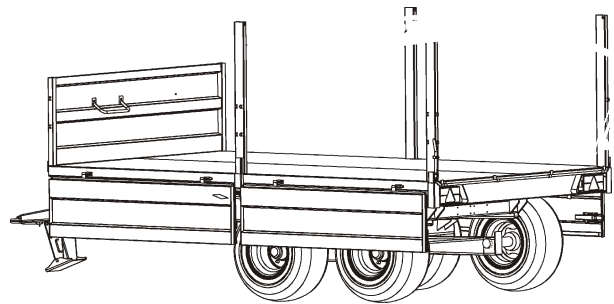

Intermediate bar

Hang the rear grain plate to the holders at the end of the poles. The side plate is 80 cm high and its lower edge includes two hinge pegs. Lift the side grain plates to its place. String the plates to the holders at the end of the poles in about 15 °.

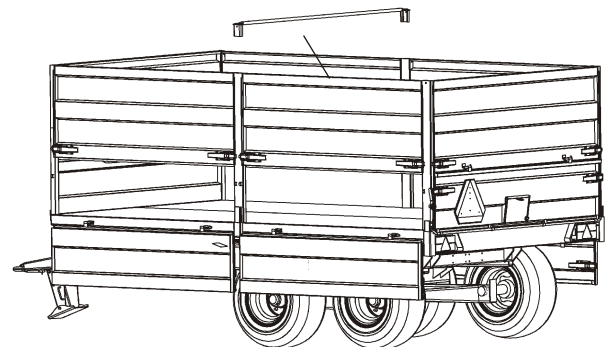

Hang the rear basic side plate to the pegs on the grain plate. The rear basic plate is equipped with a grain hatch.

Attach the intermediate bar.

Close the side plates by turning them up. Close all side plate locks.

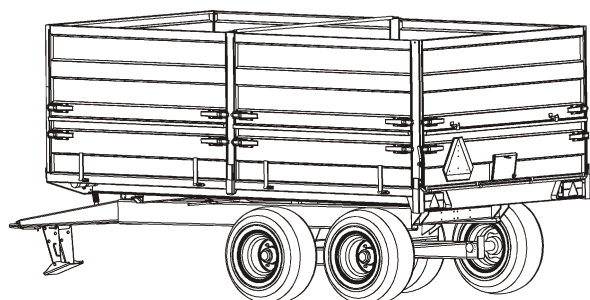

9.3.3 REAR PLATE LOCKING AND SEALING

The rear plate is sealed tight when the locking bar has been locked.
 Note! The rear plate rises a little before locking, due to the hinge points. The locking bar is easy to use with the use lever on the side of the trailer.

Use/lock switch

The rear plate fastener is locked with a ring cotter.

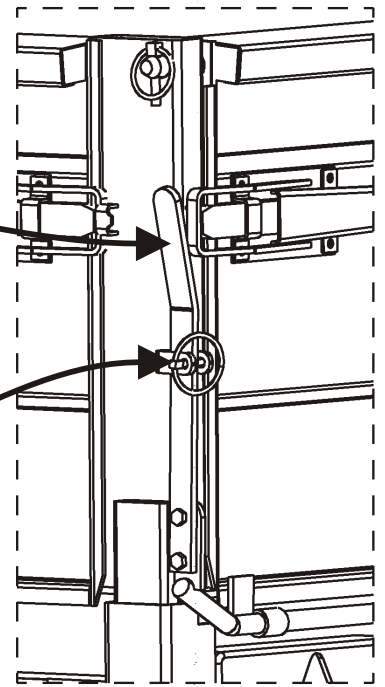

WHEN OPENING AND CLOSING THE EMPTYING PORTS, BE CAREFUL NOT TO GET YOUR FINGERS AND HANDS CRUSHED.

9.4 ASSEMBLY OF THE ACCESSORIES

FRESS FODDER EQUIPMENT:

Manual for fress fodder equipment comes with fress fodder equipment. Instructions and spare parts list

ADDITIONAL SIDE PLATES

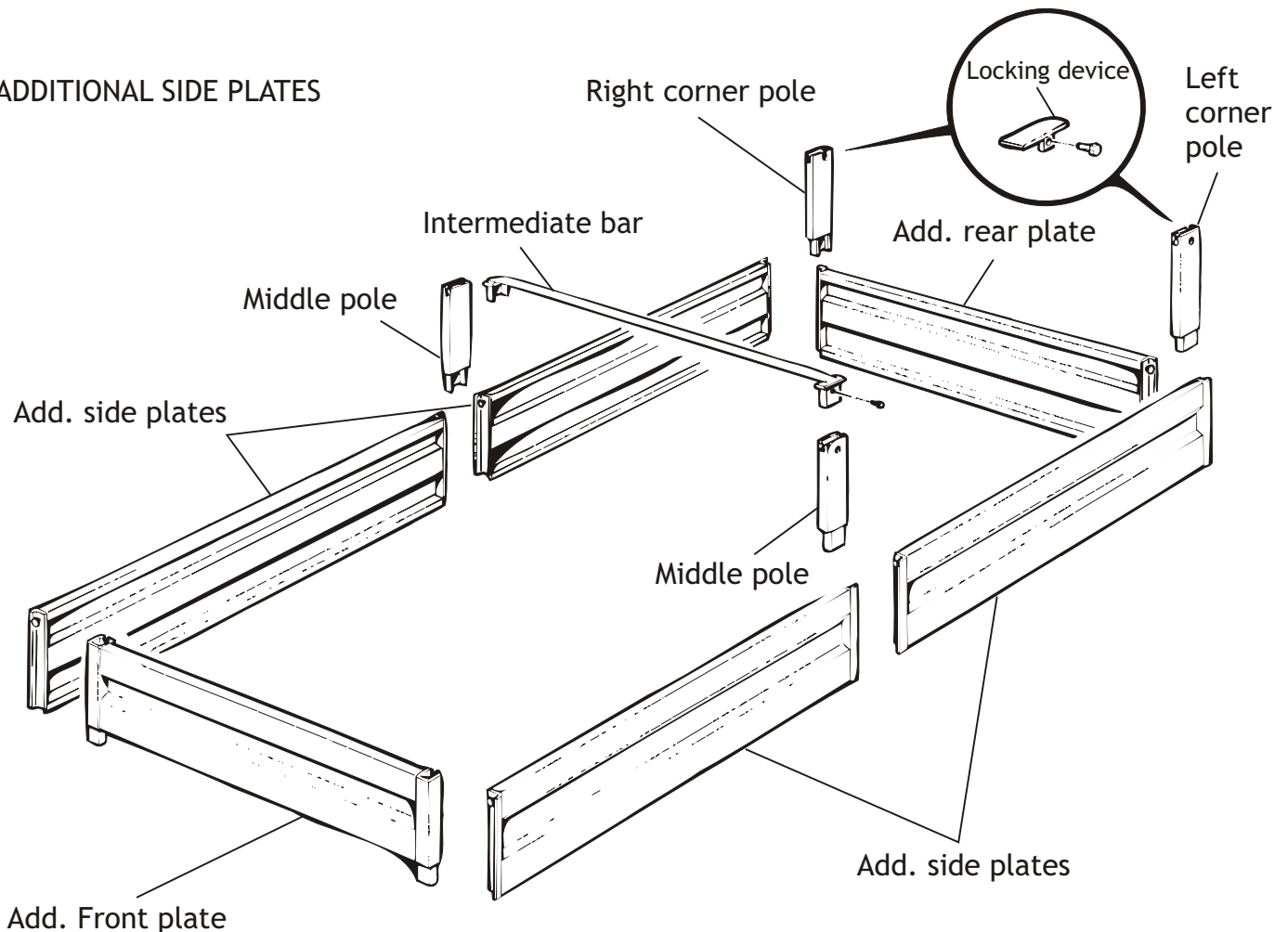

1. First install the additional front plate.
2. Put the extensions of the middle poles in place. (Remove the intermediate bar from the grain side plate middle poles.)
3. Install the extension of the right and left rear corner pole on top of the old ones. Take into consideration the attachment slots required by the side plates.
4. Lift the additional rear plate to its place.
5. Place the additional side plates.
6. Install the intermediate bar on the middle poles and lock it with screws.
7. Lock the side plates and rear plate with the locking device. See the picture on the previous page.

Additional side plates installed in place

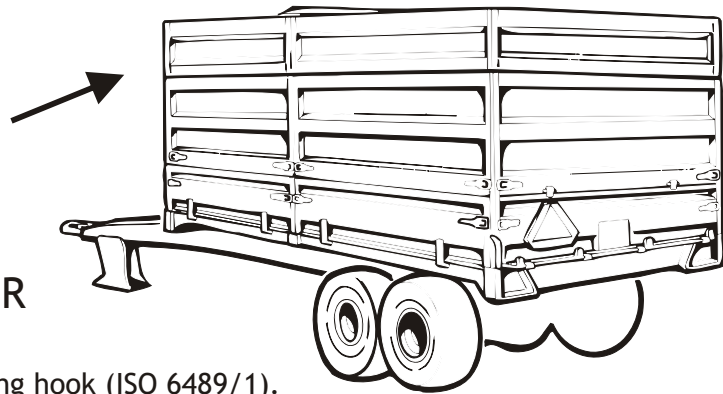

9.5 ATTACHING TO A TRACTOR

The trailer is connected to the tractor towing hook (ISO 6489/1).

HYDRAULICS

The trailer needs 1 single-function hydraulics output equipped with a quick coupling according to standard ISO 7241-1.

INSTALLATION

NOTE! DURING INSTALLATION THE PLATFORM MUST BE IN THE LOWER POSITION.

TAKING INTO USE

We recommend that if the trailer is used with more than one tractor, that you use the same type of oil, because when used the oils will mix together.
The hydraulics oil filled at the factory is NESTE 32.

USE

The tipper hose is connected with a quick coupling. The end of the hose is connected normally to the tractor. After this the trailer can be used normally as a tipper trailer with the tractor hydraulics.



NOTE! HYDRAULICS HOSES CANNOT BE DISCONNECTED FROM THE TRACTOR, THE TIPPING CYLINDERS OR CONNECTORS WHEN THE PLATFORM IS RAISED.

It is recommended that the hydraulics of the loaded trailer is not disconnected from the tractor, even if the platform is in the lower position. Pressure may remain in the system due to the trailer's structure. Pressure can be removed so that you may drive with the trailer while keeping the tipping lever in the down position. Don't store the trailer with the tipper upper position.



PRESSURISED HOSES CAN NEVER BE EMPTIED BY RUBBING OR PRESSING ON THE QUICK COUPLING, BECAUSE THERE IS ALWAYS A DANGER OF PERSONAL INJURY AND SOIL CONTAMINATION.

DO NOT EXCEED THE MAXIMUM PRESSURE OF THE HYDRAULICS SYSTEM, 210 bar.

J-10D rear side hydr.hose

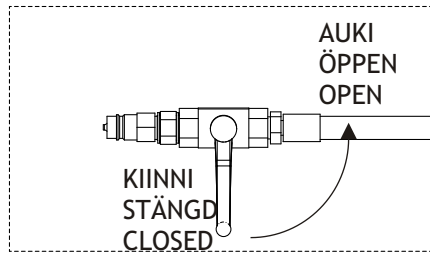

Electrical circuit diagram :



12V DC

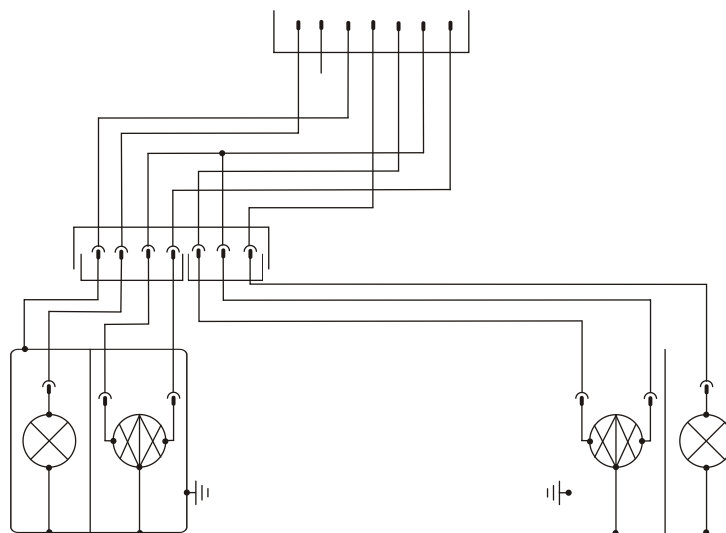

LIGHT DEVICES

Light devices are connected to the trailer connecting terminal of the tractor. The connecting terminal must be 7-pin according to standards SFS 24272 and DIN ISO 3732. The light devices work with direct current with the nominal voltage of 12V.

1. LEFT TURN SIGNAL
2. FREE
3. FRAME
4. RIGHT TURN SIGNAL
5. RIGHT REAR LIGHT AND BADGE LIGHT
6. BRAKE LIGHTS
7. LEFT REAR LIGHT

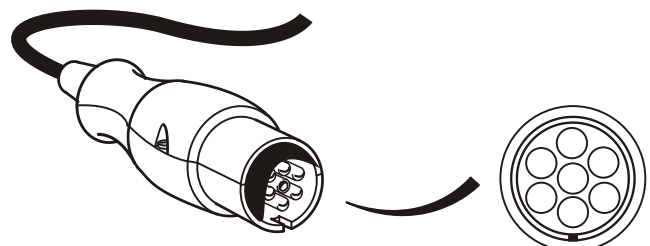
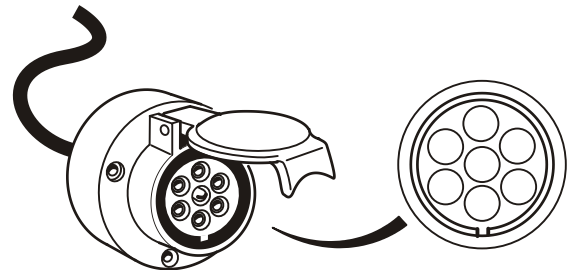

BRAKES

Compatibility with the tractor

Generally, modern tractors have the ability to use the trailer's brakes with the tractor's own brake system. In these cases the tractor must include its own brake block and output connector for the trailer brakes. This equipment are usually accessories, so for a standard agricultural tractor they must be ordered either at the time of purchase or later as a separate accessory package.

The brake pressure the tractor provides usually depends on the pedal power; in a tractor the maximum limit is 150 bar. In this case the compatibility depends on the relative pressure difference between the tractor and the trailer.

In tractors where the trailer brake pressure can be selected, the pressure difference is given as ratios, e.g. 1/5.44. The ratio means that the trailer brake system has 5.44-times the pressure of the tractor brake system. In these systems the maximum pressure produced by the tractor is usually also limited to 150 bar.

A suitable brake ratio depends on the use of the trailer, but generally a fairly low ratio is the best. In practice this means that the brake pedal power must be fairly large to achieve maximum pressure.

The trailer brakes can be used also through the tipper hydraulics. The tipper hose is connected with brake hose through ball valve. Now you can choose the hydraulic function by ball valve either to brakes or to tipper.

To function, the brake needs one single-function hydraulics output equipped with a connector according to standard ISO-7441-1.

The system pressure is limited to 120 bars. Keep in mind that using brakes on general roads requires that the trailer brake lights function simultaneously with the brakes.

TYRES

They use STRO- (Scandinavia tires and rim organization) standard tyres in JUNKKARI trailers. STRO-standard defines tyretolerances and tyres have been carefully checked.

If the tyres still tremble there can be various reasons. One common reason is so called Flat-spot which appears when driving with load. Tyres warm up in use and cool down during breaks and the surface of tyre which stays against the ground cool down as flat. After driving again this spot trembles until the tyre has warm up and comes fully round. This is a normal phenomenon, which the tyre manufacturers has approved in construction machines and in slow drive. Speed, tyre pressure and load have all an effect on tyre to tremble and wear. Look chapters: 10. Checks (tyre pressure) and 11. Loading

10 CHECKS

- Check the tyre pressures regularly.

Tyre	Pressure kPa
400/60-15.5/14	350 (Mitas)
500/50-17/14	350 (Mitas)

- Check that the oil hose connectors are compatible with the tractor.
- Check the functioning of the lights. The rear, indicator and brake lights are connected according to a European standard. If the lights do not function correctly in the check, make sure that the tractor electric output has been connected according to the standard.
- Before using, the platform must be tipped when empty 2-3 times. The tipping cylinder has been test-pressurised on the factory, after which the oil has been removed.
- Check the tightness of the wheel nuts and screws (about 250Nm=25kpm) after three hours of driving. Re-check 2-3 times a year depending on the use. See the picture below.
- Tighten all screws and nuts twice during use season.
- Check the compatibility of the tractor brake output with the trailer if the tractor includes a separate brake output hydraulics.

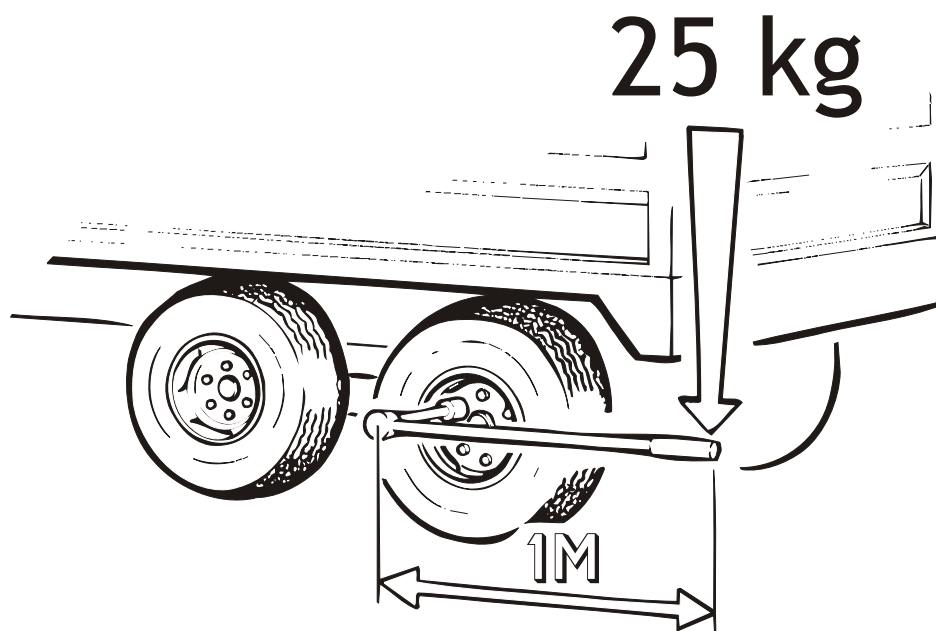

TIGHTENING THE WHEEL BOLTS

11 LOADING

1. Take into consideration the trailer carrying capacity and the road legislation, because then the warranty is also valid.

NOTE! THE TABLE 1 IS REFERENTIAL.

TABLE 1.

MATERIAL	VOLUME PP .. Kg/m	ALLOWED HEIGHT OF THE LOAD cm
FERTILIZER	1100	90
SAND	1900	52
CLAY	2000	50
ROCK	3000	33

2. Always make sure the load is fastened and stays on the platform.
The load and its transporting are always the driver's responsibility.

12 USE

WHEN THE TRAILER IS UNLOADED, FAMILIARIZE YOURSELF WITH ITS FUNCTIONS. MAKE SURE THAT THE TIPPING IS ALWAYS SUFFICIENTLY HARD AND STRAIGHT (NOT SLANTED).

12.1 NORMAL TIPPING

Be careful not to damage the rear plate. This can occur due to the large tipping angle. THE REAR PLATE MUST ALWAYS BE OPENED BEFORE TIPPING! When tipping moist grain, you must open both rear plates (grain platform).

WHEN TIPPING, THE TRAILER MUST ALWAYS BE CONNECTED TO THE TRACTOR.



THERE IS ALWAYS A DANGER IF THE TRAILER IS MOVED WHEN THE TIPPER IS UP.

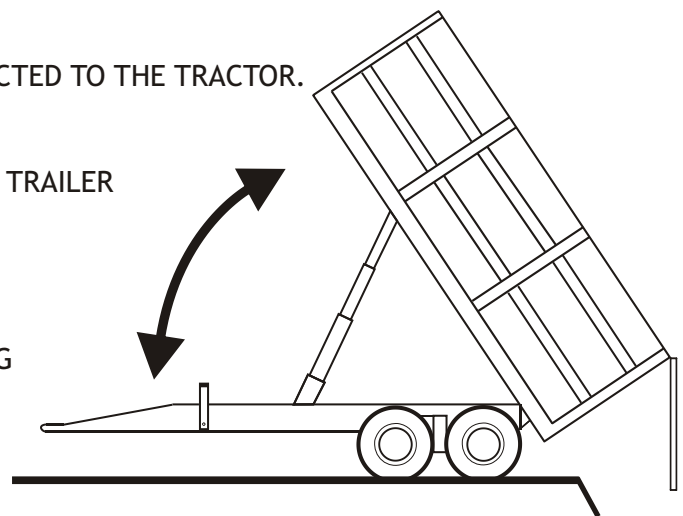

PAY ATTENTION TO THE RISKS INVOLVED WHEN TIPPING IN A LOCATION WHERE THERE IS AN ELECTRIC WIRE (OR SOME OTHER LIMITING BLOCKAGE) ABOVE THE TRAILER.

12.2 LOWERING THE PLATFORM

Lowering takes place in reverse order. If the service support has been raised, lower it. When lowering the platform, always make sure that there is nothing between the platform and the body, which would cause a danger or injury.

13 SERVICE

13.1 LUBRICATION DIAGRAM

LUBRICATION INSTRUCTIONS

1. Bogie bearings 4 times per use-season or every 500h.
2. Tippers fasteners 4 times per use-season.
3. Every joint pin in frame at least 4 times per use-season.
4. Adjust the brakes once per use-season or as needed. (See instructions)

When lubricating, you must make sure that the lubricant goes to the correct location. For example: when greasing the articulation bearings of the bogie swings, the trailer must first be lifted (e.g. 10cm) off the ground so that the grease goes to the pressurized sliding surfaces. When greasing the articulation bearings, the bogie swing must be swung periodically.

TARGET	LUBRICANT	SERVICE INTERVAL
A. BOGIE SWING AXLE	VASELINE	500 h
B. HYDRAULICS	HYDRAULICS OIL SAE20 WTAI SAE 10 W	See section 13.2
C. JOINT PINS OF FRAME	VASELINE	Use-seasonally 2-4 times
D. PLATFORM LOCKS	CRC OR CORRESPONDING.	Use-seasonally 2-4 times
E. HUB BEARINGS	VASELINE	1 year see section 13.4
F. COUPLING CLUTCH	VASELINE	500 h

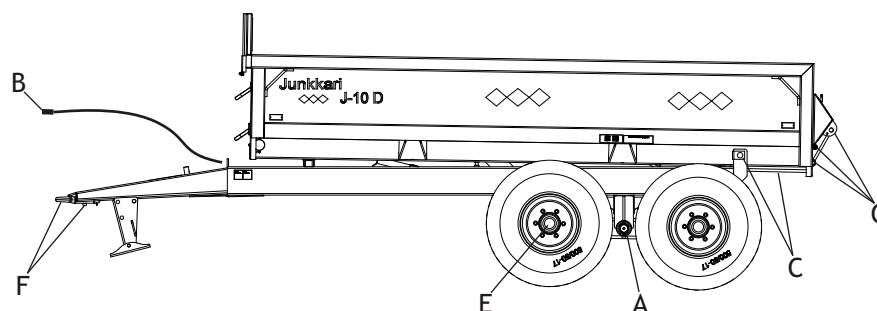
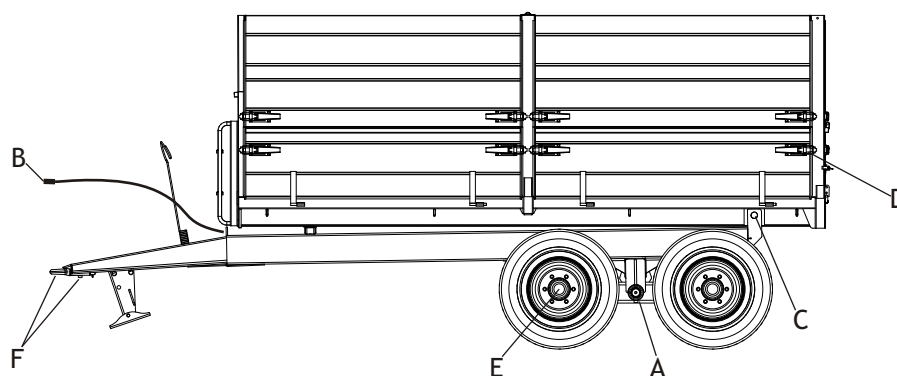

13.2 HYDRAULICS MAINTENANCE

Check the oil amount in the tractor after the first lifting and tipping and add oil if needed. During the first lifts, the cylinder may let out some oil to the cylinder surface; this is perfectly normal, and will disappear with time when the seals are honed to form.

13.3 ADJUSTING THE BRAKES

The brakes must be adjusted once per use season or as needed. The brakes are adjusted by turning the brake lever in the brake axle in the following way:

- A) Remove the fastening pin of the brake cylinder piston arm.
- B) Remove the brake lever.
- C) Turn the brake lever with the brake axle boron so that when braking, the free movement at the end of the brake lever is about 4cm.
- D) Lift the wheel into the air and, by turning with both hands, make sure that the brakes are not "on."

13.4 ADJUSTING AND TIGHTENING THE HUB

The castle nut is tightened until the hub no longer rotates by hand. After this, the nut must be loosened by one fifth of a turn. Then put the cotter pin in the slot nearest to the castle nut. Check that the wheel rotates freely by rotating by hand.

With the calculated loads, a suitable bearing clearance is 0.05-0.15mm.

Pay attention to the possible heating of the bearing during the first kilometres of driving; check the clearances after driving for three hours. Adjust when needed.

Change grease every year. Bearing must be full of grease.

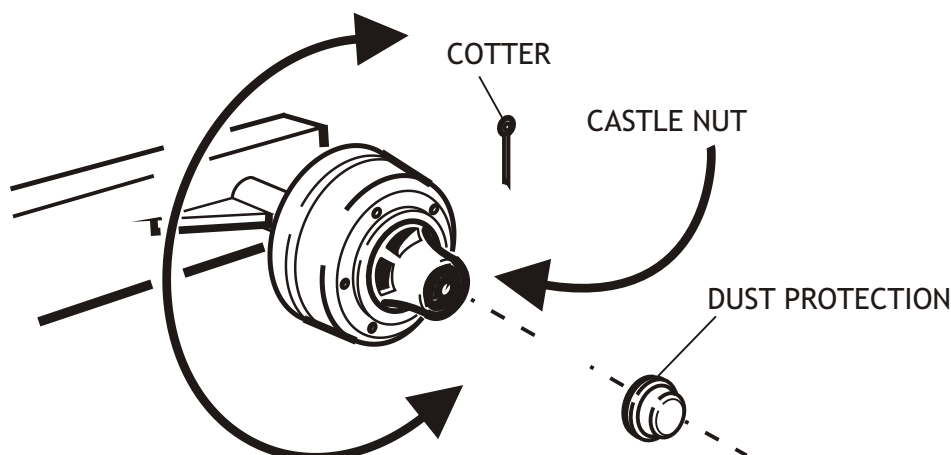

14 TROUBLESHOOTING DIAGRAM

FAULT	CAUSE	ACTION	NOTES
The hydraulics hoses do not come loose from the connectors	Hydraulics system pressure	Remove the pressure from the system	
Hub heats up	Bearing damaged, little grease in the hub, the hub is too loose/tight	Change the bearing when necessary. Lubricate the hub Adjust the tightness of the hub	See hub adjusting-instructions
The platform lowers with jerks	Air in the tipping cylinders	No actions needed	Air is removed with use over time from the hydraulics system
The tipper does not rise	The quick coupling of the tipper hose is not compatible with the tractor connector.	Change the quick coupling to a suitable one	Standard quick couplings are not necessarily compatible with each other, even though the couplings would attach to each other.
The tipper rises a little or badly.	There is little hydraulics oil leaks in the system	Check that there are no leaks in the hydraulics system. Also check the tractor hydraulics and the amount of hydraulics.	
The platform lowers very slowly	The tractor hydraulics uses other hydraulics as well (e.g. hydraulics switch etc.)	No actions needed	Counter-pressure is formed in the hydraulics hose from the tractor.
The platform will not lower	Hose breakdown valve is working	Check the condition of the hoses.	

The normal wearing of the tipper trailer takes place safely and does not cause dangerous situations.



You must take into consideration that if the machine is used against traffic rules and safety instructions, or if the machine is overloaded and not serviced, there is always a danger of unusual wear or breakdown that may harm both people and the environment.

15 WITHDRAWING THE PRODUCT FROM USE

READ SAFETY INSTRUCTIONS



Withdrawing the product from use is the responsibility of the end user of the product or the person or company that owns the product when it is decommissioned.

There are national laws, instructions and regulations regarding decommissioning the product and handling the different waste created, and these all must be followed.

Most parts of the trailer are non-decomposing materials, so the trailer must be disassembled and the different materials discarded according to national regulations.

- Iron and other metals are recycled through machine and device scrapping companies to be re-used.
- Waste oil, plastic and rubber parts other than tires are handled as problem waste and should be discarded either by recycling or by appropriately transporting them to a dump yard or discarded otherwise according to national regulations.
- Tyres must be discarded according to directives 83/189EEC, 182/88/EEC, 94/10/EU by taking the used tyres to recycling points or to recycling operators that deliver the tyres forward to be re-handled.

If needed, you can get additional information on disassembly and waste handling from the environmental authorities.

16 TERMS OF WARRANTY

- The warranty period is 12 months of agricultural use in the work that the device has been meant for.
- In a communal, industrial and professional contracting or corresponding use, the warranty time is 6 months.
- The warranty time begins when an authorised reseller delivers the new device.
- The warranty will cover manufacturing and material errors. The damaged parts are repaired or replaced to usable ones at the factory or at an agreed repair shop. The subcontracted parts have a guarantee given by their manufacturers.
- Warranty repair does not continue the warranty period.
- The warranty will not cover damages that are caused by erroneous use against the instruction manual or by erroneous service, excessive loading or normal wear. The warranty will not cover any consequential damage, days of stoppage, travel expenses, cargo payments, daily allowances, overtime work or changing the original structure of the machine.

For warranty issues we recommend that you turn to the sales point, who will then make a warranty claim. Before taking any action, the actions and their possible costs must be agreed upon beforehand with the manufacturer.

The warranty is valid only if the warranty card is returned appropriately filled to the manufacturer within 14 days of date of delivery.

17 RESPONSIBILITY AREAS

The manufacturer is not liable if the machine is used against laws, safety instructions or this manual. When using the machine, situations may occur that do not have related instructions or regulations; therefore, the user is recommended to act accordingly to common machine safety instructions and directives.

The manufacturer is not responsible for any damage caused by using components made by other manufacturers.

The manufacturer is not responsible for any damage caused to other machines or devices by using the trailer.

The manufacturer is not responsible for any damage caused by incorrect fodder.

The manufacturer is not responsible for damage caused by foreign objects and overfilling.

The manufacturer reserves the right to further develop or change the machine structure.

EY -VAATIMUSTENMUKAISUUSVAKUUTUS KONEESTA**(FI)**

Valmistaja Junkkari Oy
Osoite Pohjanmaanväylä 5, FIN-62375 YLIHÄRMÄ

Vakuutamme yksinomaan omalla vastuullamme, että markkinoille saatettu kone

JUNKKARI J10 KIPPIPERÄVAUNU

valmistenumeroista **101** alkaen on soveltuvilta osin rakennettu normatiivisten asiakirjojen ohjeiden mukaan ja noudattaa direktiivien 2006/42/EY määräyksiä

EG- FÖRSÄKRAN OM ÖVERENSSTÄMMELSE FÖR MASKINELL UTRUSTNING**(SE)**

Tilverkare Junkkari Oy
Adress Pohjanmaanväylä 5, FIN-62375 YLIHÄRMÄ

Försäkrar härmed enbart på vårt eget ansvar, att för marknader tillverkad maskin

JUNKKARI J10 SLÄPVAGN

f.o.m tillverkningsnummer **101** är tillverkad i tillämplig mängd i överensstämmelse med instruktioner av det normativa dokumentet följer bestämmelser av följande direktiver: 2006/42/EY

EC DECLARATION OF CONFORMITY FOR MACHINERY**(EN)**

Manufacture Junkkari Oy
Address Pohjanmaanväylä 5, FIN-62375 YLIHÄRMÄ

Herewith declare on our sole responsibility that for the market produced machine

JUNKKARI J10 TRAILER WAGON

from the manufacturing number **101** is manufactured, where applicable, in conformity with provisions of the instructions of the normative document according to the following directive: 2006/42/EY

DECLARATION CE DE CONFORMITE POUR LES MACHINES**(FR)**

Fabricant Junkkari Oy
Adresse Pohjanmaanväylä 5, FIN-62375 YLIHÄRMÄ

Certifions á nos propres risques, que la machine suivante commercialisée

JUNKKARI J10

et ce depuis le numéro de série **101** est en conformité avec les normes applicables et les dispositions de la directive 2006/42/EY

EG-KONFORMITÄTSEKTLÄRUNG FÜR MASCHINEN**(DE)**

Hersteller Junkkari Oy
Adresse Pohjanmaanväylä 5, FIN-62375 YLIHÄRMÄ

Erklären hiermit ausschließlic auf eigene Verantwortung, daß die Maschine

JUNKKARI J10

von der Herstellungsnummer **101** konform mit den einschlägigen Bestimmungen von dem normativen Document hergestellt ist und Bestimmungen von Direktiven: 2006/42/EU

EC SAMSVÆRSERKLÆRING OM MASKINER**(NO)**

Produsent Junkkari Oy
Adresse Pohjanmaanväylä 5, FIN-62375 YLIHÄRMÄ

Erkærer at produktet beskrevet heretter

JUNKKARI J10

f.o.m Tillverkningsnummer **101** Som omfattes av denne erklæringen, er i samsvar med instruksjonene i dokument samt bestemmelsene i følgende direktiv: 2006/42/EY.

TOEND MASINA NOU TELEVASTAVUSE KOHTA**(EE)**

Valmistaja Junkkari Oy
Address: Pohjanmaanväylä 5, FIN-62375 YLIHÄRMÄ

Kinnitamme ainuüksi omaenda vastutus el, et turule lastud masin

JUNKKARI J10 KIPPIPERÄVAUNU

valmistusnumbrid **101** on ehitatud normatiivsete dokumentide juhiste kohaselt ja vastab direktiivi 2006/42/EY nõustele

ZAPEWNIENIE ZGODNOSCI URZADZENIA Z WYMAGANIAMI**(PO)**

Producent Junkkari Oy
Adres: Pohjanmaanväylä 5, FIN-62375 YLIHÄRMÄ

Zapewniamy wylaczinie na wlasna odpowiedzialnosc, ze wprowadzona do sprzedazy

JUNKKARI J10

poczawszy od nr fabrycznego **101** jest skonstruowana w zakresie stosowalnosci zgodnie z normatywna dokumentacja i przepisami dyrektywy: 2006/42/EY

CEE DECLARACIÓN DE CONFORMIDAD PARA MAQUINARIA**(ES)**

Fabricante: Junkkari Oy
Dirección: Pohjanmaanväylä 5, FIN-62375 YLIHÄRMÄ

Declara en su misma responsabilidad que la máquina construida modelo:

JUNKKARI J10

con el numero de fabricación 101 está fabricada con conformidad a las prescripciones de la normativa referente a la siguiente directiva: 2006/42/EY

Kauhavalla 12.11.2015

**Junkkari**

Harri Hytönen
Toimitusjohtaja
Managing Director