

Junkkari

TRACTOR TRAILER J16JL J16JLD

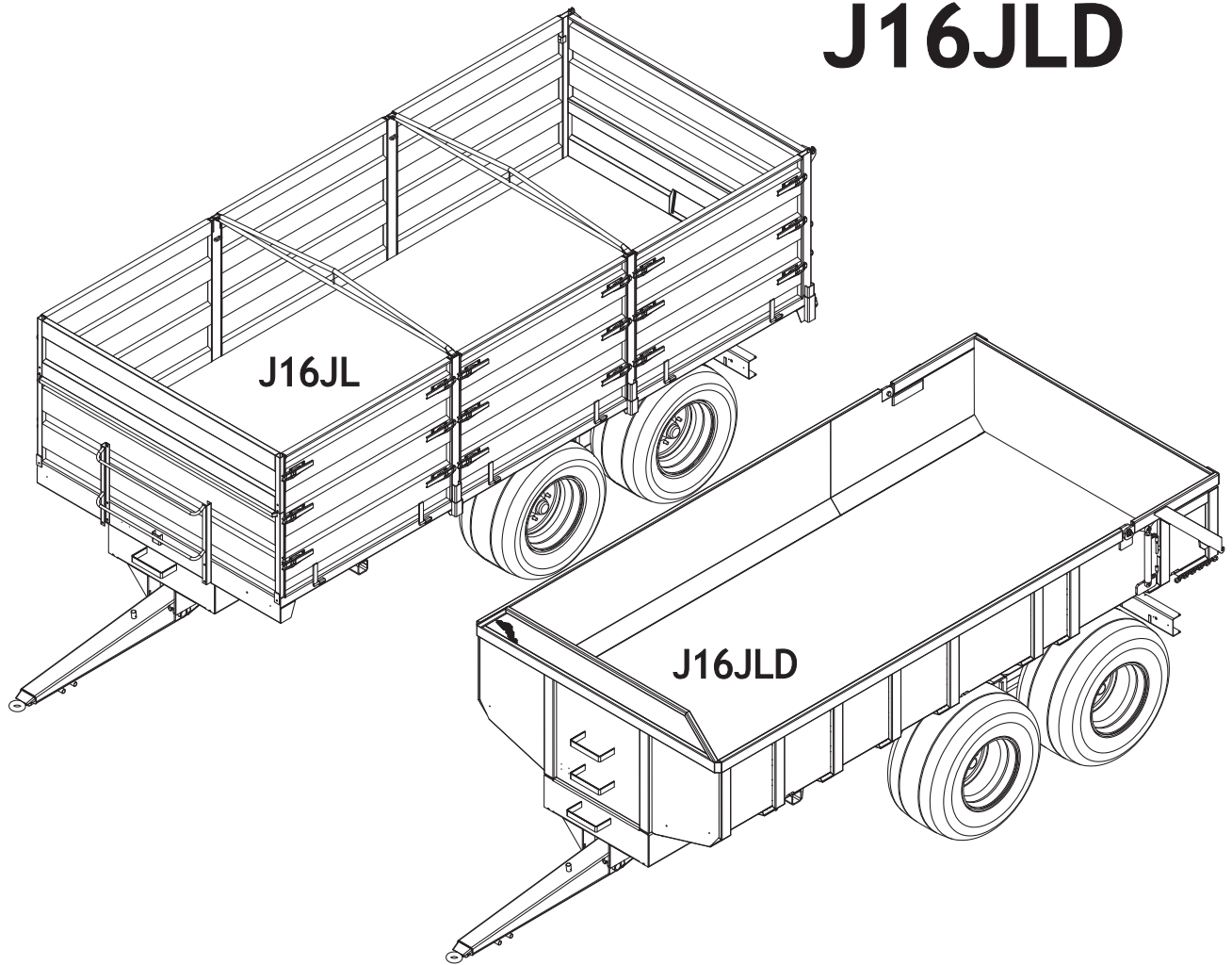

USER GUIDE SPARE PART LIST

J16-09EN

Junkkari Oy
62375 YLIHÄRMÄ FINLAND
TEL. +358-(0)6-4835111
FAX +358-(0)6-4846401
e-mail: junkkari@msk.fi
Internet: www.junkkari.fi

ENGLISH 

1 TABLE OF CONTENTS

	PAGE
2	INTRODUCTION..... 3
3	TECHNICAL SPECIFICATIONS..... 3
4	SAFETY INSTRUCTIONS..... 4
	4.1 GENERAL SAFETY INSTRUCTIONS..... 4
	4.2 SPECIFIC SAFETY INSTRUCTIONS FOR TIPPER TRAILERS..... 4
	4.3 TRANSPORT AND MOVING..... 5
	4.4 HYDRAULICS..... 5
	4.5 SERVICE AND REPAIRS..... 6
5	SAFETY LABELS AND COMPONENTS AND THE TYPE PLATE..... 6
	5.1 SAFETY MARKINGS..... 6
	5.2 LIGHTS AND SLOW VEHICLE SIGN..... 10
	5.3 BRAKES..... 10
	5.4 TYPE PLATE..... 11
6	OPERATING ENVIRONMENT..... 12
	6.1 PURPOSE OF USE..... 12
	6.2 USE RESTRICTIONS AND PROHIBITED FORMS OF USE 12
7	FUNCTIONING PRINCIPLE..... 12
8	TRANSPORTING, HANDLING AND STORING THE MACHINE..... 13
	8.1 TRANSPORTING..... 13
	8.2 HANDLING..... 13
	8.3 STORING..... 13
	8.4 SPECIFIC SAFETY INSTRUCTIONS FOR MACHINE TRANSPORT..... 13
9	PUTTING TO USE..... 14
	9.1 CONTENTS OF THE PACKAGE AND DISCARDING THE PACKAGING MATERIALS..... 14
	9.2 ASSEMBLY..... 14
	9.2.1 INSTALLATION INSTRUCTION FOR GRAVEL SIDE PLATES..... 15
	9.2.2 INSTALLATION INSTRUCTION FOR GRAIN SIDE PLATES..... 16
	9.2.3 LOCKING AND SEALING THE REAR PLATE..... 17
	9.3 ASSEMBLING THE ADDITIONAL SIDE PLATES..... 17
	9.4 CONNECTING TO THE TRACTOR 18
10	CHECKS..... 20
11	LOADING..... 21
12	USING..... 21
	12.1 NORMAL TIPPING..... 21
	12.2 LOWERING THE PLATFORM..... 21
13	SERVICE..... 22
	13.1 LUBRICATION DIAGRAM..... 22
	13.2 HYDRAULICS MAINTENANCE..... 23
	13.3 ADJUSTING THE BRAKES 23
	13.4 ADJUSTING AND TIGHTENING THE HUB..... 23
14	REMOVING THE PLATFORM..... 24
15	ATTACHING THE PLATFORM..... 27
16	TROUBLESHOOTING DIAGRAM..... 28
17	WITHDRAWING THE PRODUCT FROM USE..... 29
18	TERMS OF WARRANTY..... 30
19	AREAS OF RESPONSIBILITY..... 30
	DECLARATION OF CONFORMANCE TO EU REGULATIONS
	SPARE PART LIST



Warning sign

The manual always uses this sign to indicate danger to the user or others. This sign is also used to indicate danger to the environment or property.

2 INTRODUCTION

We thank you for your trust and wish you the best success with your work. We ask that you familiarize yourself with this user guide, to completely understand the machine, its correct adjustments, and careful maintenance. This will guarantee user safety and continuous machine operation on busy workdays. It is important to understand and follow the instructions of every section in this guide. Please contact the seller of this machine with any questions. We recommend returning the signed warranty card to the factory after reading the user guide.

3 TECHNICAL SPECIFICATIONS

		J 16 JL (grain trailer)	J 16 JLD (dumper trailer)
CARRYING	Kg	15 700	15 700
CAPACITY TYRE		560/45R22.5 or 600/50R22.5	
PLATFORM SIZE	cm	250x547 (WITHOUT SIDES)	80x242,5x515 (INSIDE)
VOLUME WITH GRAVEL SIDE PLATES	m ³	7	10
VOLUME WITH GRAIN SIDE PLATES	m ³	17	-
WITH GRAIN SIDE PLATES	m ³	21	-
TIPPING ANGLE	1°	51	51
TIPPING CYLINDERS/PIPES	kpl	2/5	2/5
CYLINDER OIL NEED	L	28.4	28.4
PLATFORM H. FROM THE GROUND	cm	120	120
GAUGE	cm	190	190

ACCESSORIES FOR J16JL GRAIN TRAILER

GRAVEL SIDE PLATES(51.5cm)	yes
ADDITIONAL SIDE PLATES FOR GRAIN SIDE PLATES (30 cm) FRESH FODDER EQUIPMENT (34 m3)	yes

Your machine data

Type: _____

Manufacturing: _____

Number: Model: _____

CONTENTS OF THE SUPPLIES PACKAGE (J1 6JL):	pcs	part number
Outside step	1	25124
Inside step	1	1107120
Grain side plates	6	25614
Grain plates on the front & back	1+1+1+1	25455, 25615, 25465, 25586
Poles for grain plates	1+1+4	
Intermediate bar	2	25144
Hatch in the basic rear plate	1	1785321
Hydraulics hose support	1	D14111
Rear plate opening lever	1	29236
Instuction manual	1	

4 SAFETY INSTRUCTIONS



4.1 GENERAL SAFETY INSTRUCTIONS

- **CLOTHING:** For your own safety, wear well-fitting clothes with no loose sections.
- **USE:** Before using the trailer, familiarize yourself with its connection, controls, and overall operation.
- **WARNINGS:** Follow all warnings and instructions attached to the trailer.
- **GUARD PANELS:** The trailer can be used only when all the guard panels are in place and in good condition.
- **CONNECTING TO A TRACTOR:** Use caution when connecting or disconnecting the trailer.
- **LOADING THE PULLING DEVICE:** Take into consideration the maximum capacity allowed for loads when using the drawbar and tractor.
- **PARKING:** Make sure the trailer is properly secured when in the parked position.
- **SAFETY DISTANCE:** Because of its operating principle, the trailer includes parts that are not fully protected. You must keep a sufficient distance from these parts at all times. The operator must also make sure that bystanders stay clear of these parts.
- **WORKING WITH THE TRAILER:** When working with the trailer, it is forbidden to be in the near vicinity.
 - ✍ Check the fastening of a new trailer's parts and that all parts rotate freely.
 - ✍ Trailer cleaning, lubrication or adjustments must not take place when the power output and hydraulics of the trailer are connected.
 - ✍ Before starting your work, you must make sure that no one is under or behind the trailer, or on its platform.
 - ✍ Before exiting the control cabin set the gear on neutral and engage the parking brake.
 - ✍ Do not let children or extra passengers in the cabin during use.
 - ✍ Check the tightness of the wheel bolts after the first three hours of driving.

4.2 SPECIFIC SAFETY INSTRUCTIONS FOR TIPPER TRAILERS

- ✍ The tipping direction of the platform must be selected so that the trailer's side is facing the tipping site and the trailer is horizontal.
- ✍ The manufacturer is not responsible for any damage caused by overloading the trailer.
- ✍ The support of the drawbar and frame must be in the upper position during driving.
- ✍ Remember to keep the hydraulics use lever in the emptying position long enough to release the pressure from all use targets.
- ✍ Being under a tipped platform or the intermediate frame is prohibited, unless they are supported.
- ✍ Vaulting the material to be transported can cause a danger of tipping over.
- ✍ When the side plates are turned down, tipping is absolutely forbidden.
- ✍ Service support is meant only to support an empty platform.
- ✍ Make sure that the tipper hydraulics is pressure-free when you use the service support and that the platform rests well on the service support.
- ✍ The intermediate position of the drawbar support is meant to be used only when the trailer is empty. Using it on a loaded trailer is prohibited.

4.3 TRANSPORTING AND MOVING



- ✎ Always follow traffic rules and regulations when driving on general roads.
- ✎ Before using the trailer, make sure that the brake system is connected and that it works properly.
- ✎ Inspect and install all necessary accessories needed to travel on general roads, such as lights, reflectors and slow vehicle warning sign.
- ✎ Take into consideration the allowed axle weights, total weights and transport measurements.
- ✎ When using maximum load, the trailer's allowed maximum driving speed is 40 km/h.
- ✎ When using the shredder frame, make sure that the drawbar locking is secured and that the trailer has been moved to travel in line with the tractor.
- ✎ It is important that you always follow the allowed axle and shaft weights, as the trailer load will affect the behaviour of the tractor during transport, how the tractor can be directed, and how the brakes function.
- ✎ Passengers may not be transported in the trailer
- ✎ The trailer can be lifted only from the places marked with instructions labels.
- ✎ Use only approved lifting straps or chains. Please check their condition before using.
- ✎ When transporting a trailer, it must be tied securely to the platform with chains or straps.
- ✎ When loading (e.g. with a forklift), you must make sure that the trailer is balanced and in no danger of dropping.

4.4 HYDRAULICS

- ✎ Connecting the hydraulics system causes high pressure to occur. Hydraulics oil bursting out with high pressure will permeate skin and may cause serious injury. A risk of injury exists also when leak points are searched for.
- ✎ Be careful with all hydraulics parts, as there is a danger of being pressed and cut by these parts.
- ✎ The hydraulics connectors must not be removed when the machine is on hydraulics only, because then pressure will remain in the system. First close the hydraulics faucets in the rear plate and lower the platform.
- ✎ When connecting the hydraulics hose to the tractor, the hydraulics must not be pressurised from the machine or tractor side.
- ✎ Do not exceed the hydraulics oil maximum pressure of 210 bar.

PROTECTING FROM OILS AND GREASES

- ✎ When handling oil or grease, always use appropriate protective clothing and oil-proof gloves.
- ✎ Avoid skin exposure to oil and grease. The skin may be damaged.
- ✎ Never use oil or lubrication grease to clean the skin! These substances may contain small metal fragments that cause cuts to hands and the oil will make the cuts worse.
- ✎ Follow the handling instructions and safety regulations of the lubricant manufacturers.
- ✎ Synthetic oils are often corrosive and cause strong skin irritation.

WASTE OIL

Waste oil must be collected and disposed of according to national regulations.

ACCIDENTS

- ✎ If oil enters the soil, you must stop it from spreading and collect it (e.g. by absorbing it to peat).
- ✎ If oil or lubricant cause skin injuries, contact a physician immediately.



HUOM ! Kiristä pultit 3 tunnin ajon jälkeen.

OBS ! Spänn bultarna efter 3 h körning.

NOTE ! Tighten the bolts after 3 operating hours

38070

Tyre pressure

400/60-15.5	14ply	350 kPa
500/50 -17	14ply	350 kPa
560/45 R22.5	146D	320 kPa
600/50 R22.5	156D	360 kPa
650/50 R22.5	163D	400 kPa
710/45 R22.5	156D	280 kPa



Machine lifting point



Danger of being pressed



Do not go under an unsupported platform

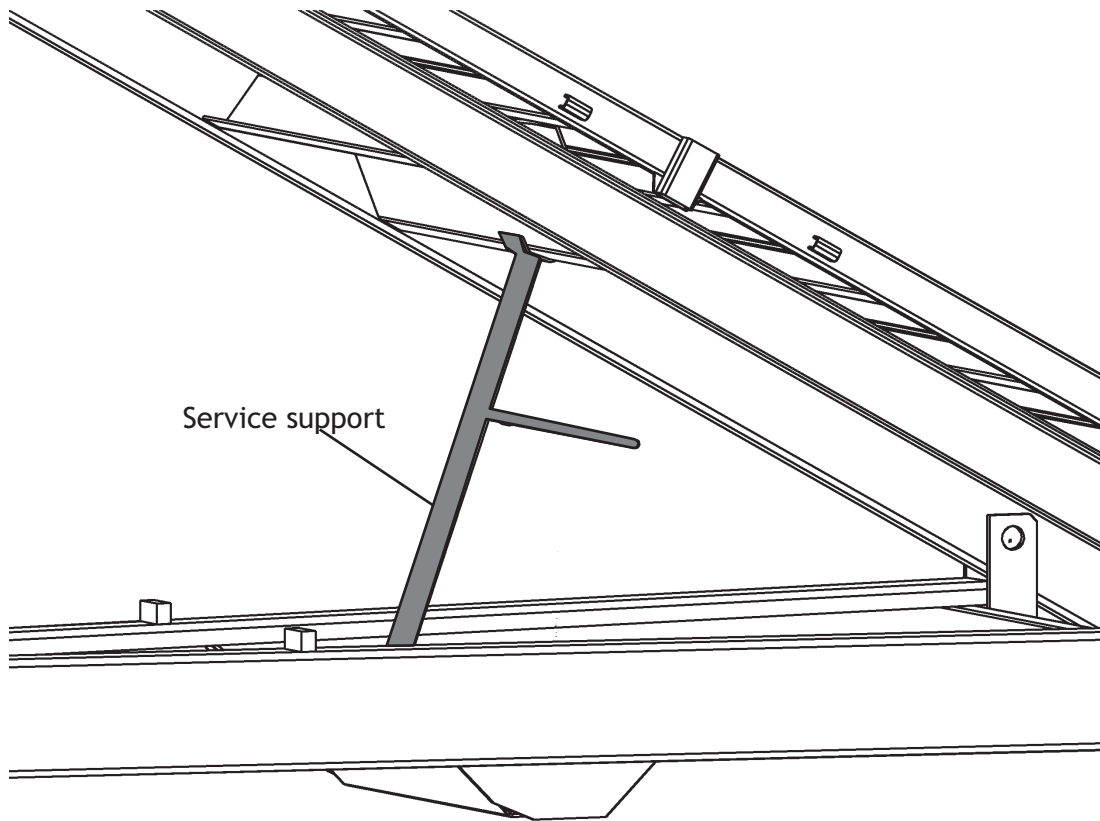

ALWAYS USE SERVICE SUPPORT WHEN WORKING UNDER A LIFTED PLATFORM

NOTE! SERVICE SUPPORT IS MEAN ONLY TO SUPPORT AN EMPTY PLATFORM.

4.5 SERVICE AND REPAIRS



- ✎ Before doing any cleaning, lubrication, installation or adjustment work, always make sure that power take-off is disabled and that the engine is stopped. Remove the ignition key to prevent inadvertent start of the tractor or machine.
- ✎ The trailer must be properly supported before starting service.
- ✎ When working under a lifted tipper platform you must absolutely support the platform with the service support.

5 SAFETY LABELS AND COMPONENTS AND THE TYPE PLATE

5.1 SAFETY MARKINGS



Danger of being pressed

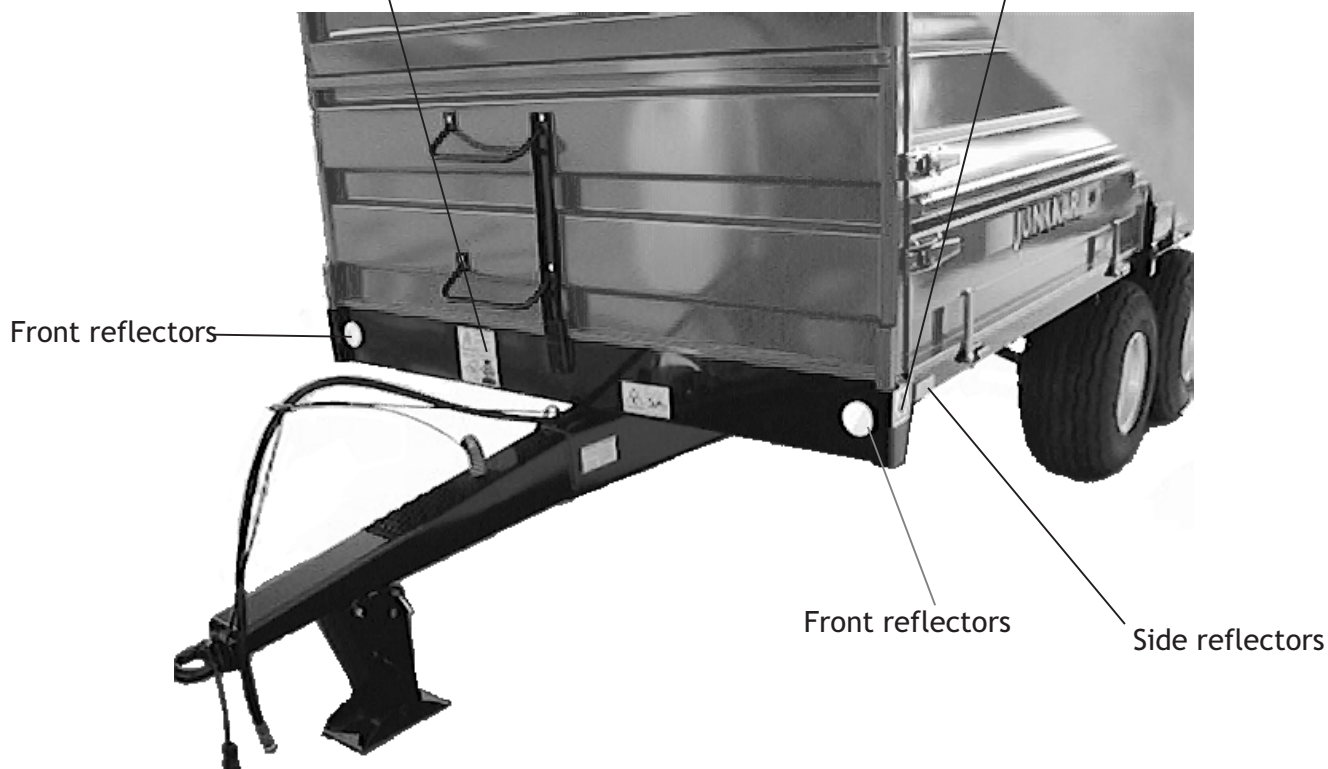



Transporting people is prohibited



14131

Do not go under an unsupported platform



62328



Machine lifting point

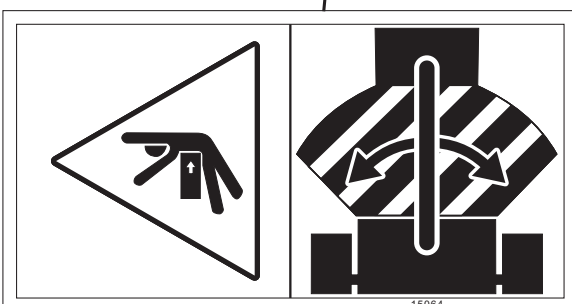

15064

Danger of being pressed between the machine and tractor

WARNING

Do not go under the tipped platform when it is unsupported. The platform support is meant only for supporting an empty

VARNING

LUTA ER EJ IN UNDER UPPTIPPAT FLAK UTAN ATT DETTA ÄR SPÄRRAT FLAKSTÖDET ÄR DIMENSIONERAT ENDAST FÖR TOMT FLAK

4-9226

5.2 LIGHTS AND SLOW VEHICLE SIGN



THE JUNKKARI TIPPER TRAILER BY DEFAULT INCLUDES LIGHT AND REFLECTOR DEVICES ACCORDING TO EU DIRECTIVES. THESE FUNCTION THROUGH THE TRACTOR 7-POLE PLUG. LIGHTS MUST BE USED ALWAYS WHEN DRIVING ON GENERAL ROADS.

ONE SLOW VEHICLE SIGN IS AT THE BACK OF THE MACHINE

REAR LIGHTS, INDICATORS AND BRAKE LIGHTS

THERE ARE TWO RED REFLECTOR TRIANGLES AT THE BACK.

THERE ARE TWO YELLOW SIDE REFLECTORS ON BOTH SIDES. THERE ARE TWO WHITE REFLECTORS IN THE FRONT. SEE THE PICTURE ON PAGE 6



5.3 BRAKES

The Junkkari J16 trailer is equipped with brakes powered by the brake valve installed in the tractor. The quick coupling in the trailer is equipped with a connector according to ISO 5676 standard.

Brakes must be used always when the national legislation so requires.

More information about brake use is on page 19.

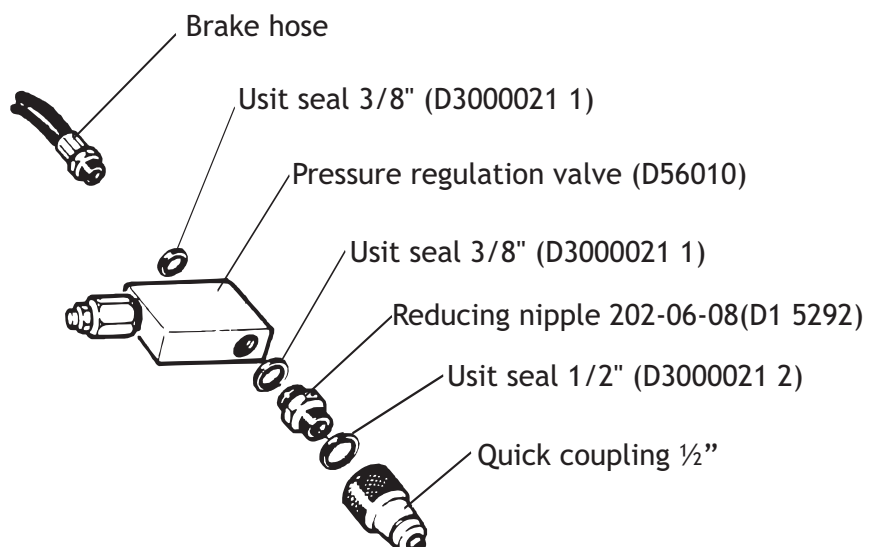

ACCESSORY:

If it is not possible to install the brake valve in the tractor, a special pressure reduction valve can be installed in the brake hose (maximum pressure = 120 bar).



5.4 TYPE PLATE

Malli	<input type="text"/>	Type
Valm.n:o	<input type="text"/>	Mfg n:o
Valm.vuos	<input type="text"/>	Year
Kantavuus	<input type="text"/>	Carr. cap
Kok. paino	<input type="text"/>	Total weight
Aks. paino	<input type="text"/>	Axle weight
Max.aisapaino	<input type="text"/>	Max.boomload

JUNKKARI OY

 62375 YLIHÄRMÄ FINLAND

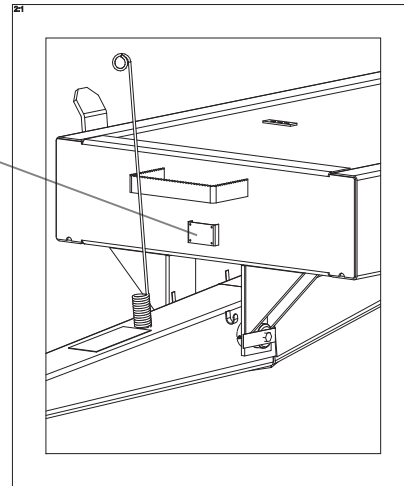

6 OPERATING ENVIRONMENT

6.1 PURPOSE OF USE

Junkkari tipper trailers are meant for transporting bulk goods and parcelled goods. The trailer can be used as a tipper trailer to transport soil and other materials, taking into consideration the set carrying capacity, recommendations and safety instructions. The grain platform provides full payload for transporting grain.

The grain platform can be equipped with additional fresh fodder side plates, so the trailer can be used effectively in transporting fresh fodder.

The soil transport platform is meant for transporting soil and gravel.

6.2 USE RESTRICTIONS AND PROHIBITED FORMS OF USE

Limitations for user

- ✍ The user must not be under the influence of drugs, alcohol or strong medicine.
- ✍ In sickness or disability cases, permission to use the device can be given by the treating physician.
- ✍ The use of the device is prohibited for all persons that lack appropriate information and skills of agriculture and for anyone fewer than 15 years of age.

Prohibited forms of use

- ✍ Any material that may corrode or erode may not be left in the trailer for an extended period of time.
- ✍ The tipper trailer must not be used in any instances where the trailer will tip over.
- ✍ Transporting people and animals or lifting them with the tipper trailer is prohibited.
- ✍ Transporting unfastened big bales is prohibited.
- ✍ Change loaded platform is prohibited.

7 FUNCTIONING PRINCIPLE

The tipper trailer is meant to be connected at the rear end of the tractor. The tipper trailer can be used to move and unload different solid materials and parcelled goods. The tipper of the grain trailer J16JLV works with the help of the tractor hydraulics. The tipper of the soil transport trailer J16JLD and the rear plate work with the help of tractor hydraulics.

8 TRANSPORTING, HANDLING AND STORING THE MACHINE

(IMPORTER, CENTRAL FIRM AND RE-SELLER)

8.1 TRANSPORTING

- ✍ The delivery term of the device is ex works, unless otherwise agreed.
- ✍ The buyer (central firm) agrees with the manufacturer regarding the time the product is ready for pick up.
- ✍ The manufacturer is responsible for loading the product.
- ✍ The transport company is responsible for the product during its transport.

8.2 HANDLING

- ✍ The product must be handled as a standard agricultural machine, carefully and without damage.
- ✍ No other products can be loaded on the product.
- ✍ The product is sent from the factory carefully packaged.

8.3 STORING

- ✍ The trailer must be stored protectively from sunlight and rain.
- ✍ When storing outside, you must check periodically that no water remains in the trailer.
- ✍ More long-term storage should always take place indoors.
- ✍ The trailer must be stored with the tipper in the lower position, to avoid rusting on the tipping cylinder pipes.

8.4 SPECIAL SAFETY INSTRUCTIONS FOR TRANSPORTING THE MACHINE



- ✍ The machine can be lifted only from the places marked with instructions labels.
- ✍ Make sure the lifting device is sufficient and that there is no danger of tipping over or falling.
- ✍ It is prohibited to lift the machine with the forks of a forklift; you must always use either straps or chains. ~ Use only approved straps or chains.
- ✍ Before lifting, always make sure the straps and chains are in good condition.
- ✍ When lifting the machine, the straps or chains must be kept tight, so that the machine cannot swing and cause a danger.
- ✍ Always check the lifting distance when using the lifts.
- ✍ For the duration of transport, the machine must be tied to the platform.

9 PUTTING TO USE

The customer is responsible for putting the trailer into use, unless otherwise agreed when purchased.

READ SAFETY INSTRUCTIONS



9.1 CONTENTS OF THE PACKAGE AND DISCARDING THE PACKAGING

Grain platform trailer J16JL:

The package includes a basic trailer, which makes one container. The instruction manual is attached at the front of the trailer under the platform. The side plates are in their own packaging.

The wooden and cardboard packaging material can be discarded by burning or by taking them to a dumpyard. The plastic bags and straps included in the packaging should be disposed of according to national regulations, by recycling or by taking them to the dump yard. Metal packaging materials should be taken to an iron collection point or to the dump yard.

Metal packaging materials should be taken either to iron collection point or to the dump yard.

9.2 ASSEMBLY

Tipper trailer J 16 JL:

The trailer is delivered with side plates removed, packed on a platform. The side plates can be installed easily. See the side plate installation instruction later on.

9.2.1 GRAVEL SIDE PLATE INSTALLATION INSTRUCTION

For trailer J16JL.

1. Unpack the materials.
2. Install the basic front side plate. It can be recognised from two vertical poles. Attach the side plate at the lower end of the poles with M10 screws. The side plate is 75cm high.
3. Attach the steps to the front side plate with screws. The separate step is meant for the inside. Install the steps opposite to each other sloping downwards.

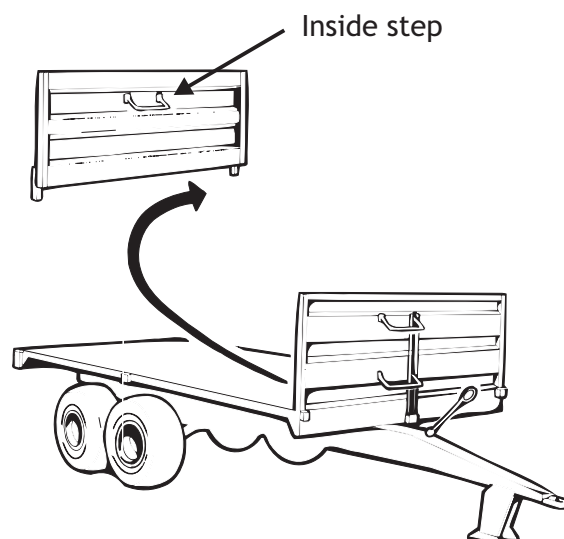
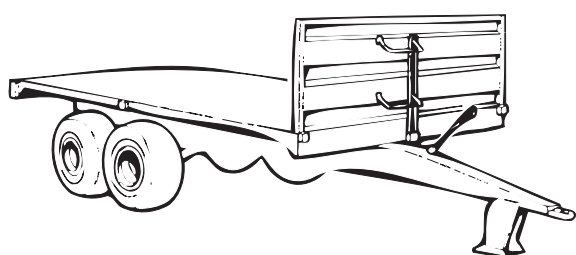

4. Install the corner and middle poles of the basic side plates.

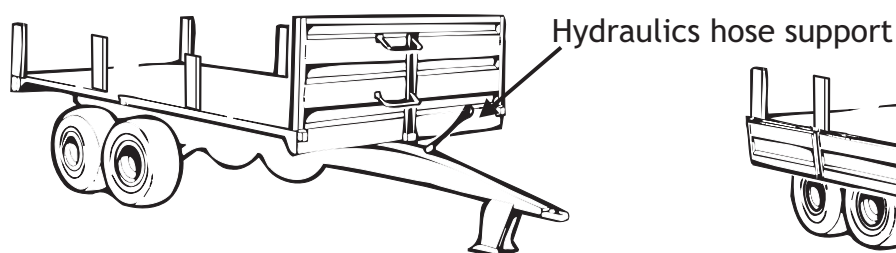

5. Install the 51 cm high gravel side plates into the trailer by pushing the hinge pegs into the hinge sleeves in the platform.

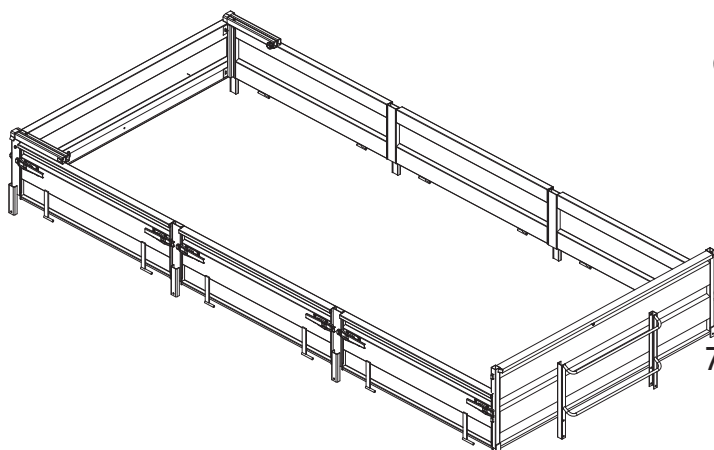
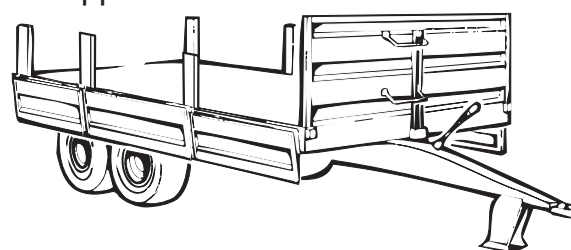

6. Install the basic rear plate and lift the side plates up. Install the hydraulics hose support to the peg in the drawbar by rotating the spring spiral in the support to the opposite direction.
7. The included loose axle pegs are used with the basic side plates. Push the pegs through the holes in the rear plate upper corners and rear poles and secure them with a ring cotter.

9.2.2 INSTALLATION INSTRUCTION FOR GRAIN SIDE PLATES

1. Unpack the materials.
2. Install the basic basic side plate. It can be recognized from two vertical poles. Attach the side plate at the lower end of the poles with screws. The side plate is 75cm high.
3. Screw the steps to the front side plate with screws. The separate step is meant for the inside. Install the steps opposite of each other, slanting downwards. Install the hydraulics hose support to the peg in the drawbar by turning the spring spiral to the opposite direction in the support.

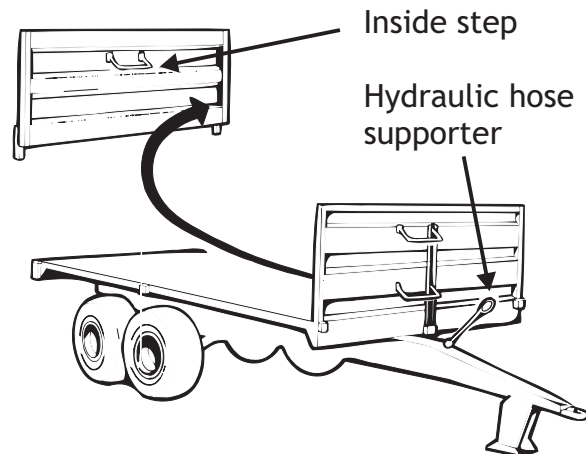
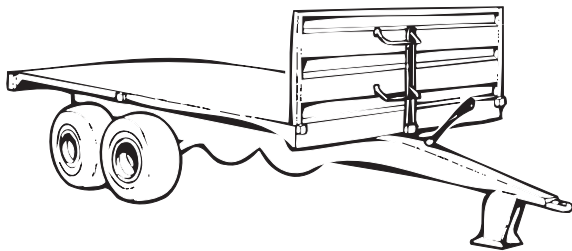

4. Install the grain side plate corner and middle poles as well as the 40cm high front grain side plate. Stand on the platform when lifting the side plate to its place. The 125cm high grain side plates are installed in the trailer from the side by pushing the hinge pegs to hinge sleeves.

5. Hang the rear grain plate to the holders at the end of the poles. The side plate is 74.5cm high and its lower edge includes two 74.5cm hinge pegs.

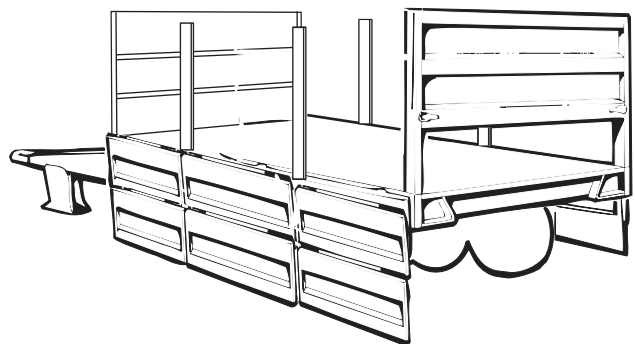
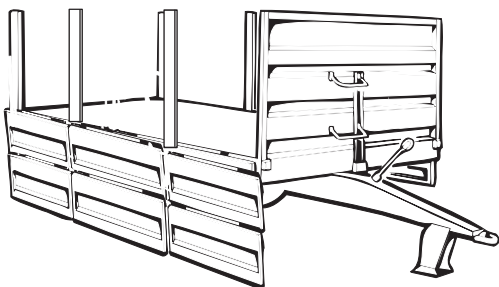

6. Attach the intermediate bars.

7. Hang the rear basic side plate to the pegs on the grain plate. The rear basic plate is equipped with a grain hatch.

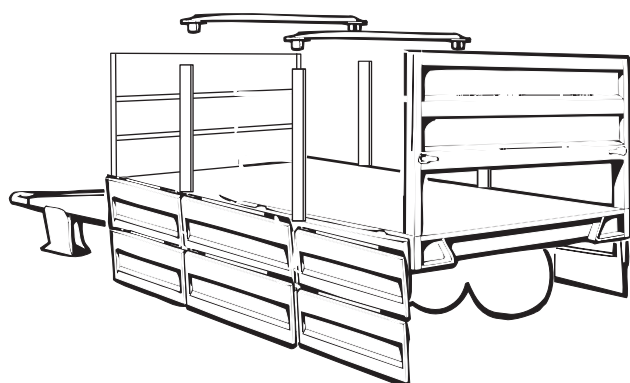

8. Close the side plates by turning them up. Close all side plate locks.

9.2.3 REAR PLATE LOCKING AND SEALING

The rear plate is sealed tight when the locking bar has been locked.
 Note! The rear plate rises a little before locking, due to the hinge points. The locking bar is easy to use with the use lever on the side of the trailer.

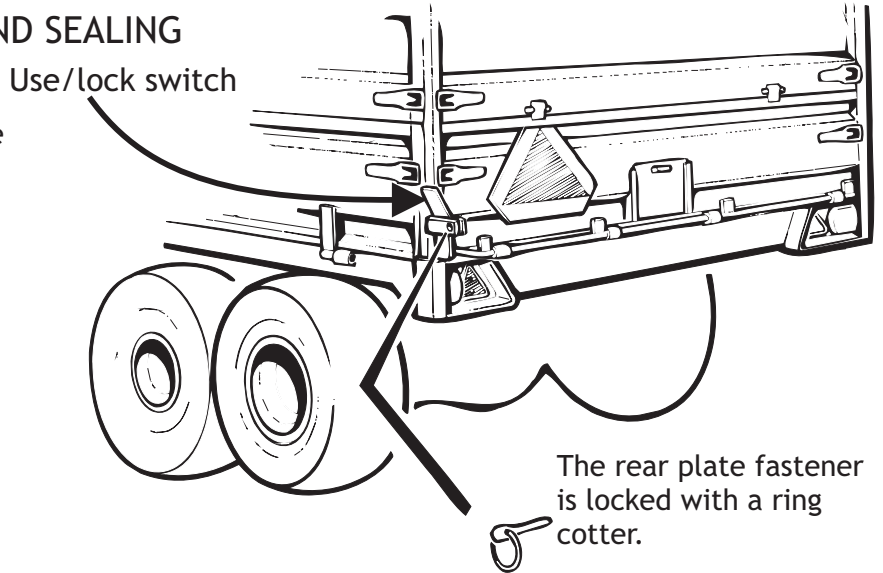

WHEN OPENING AND CLOSING THE EMPTYING PORTS, BE CAREFUL NOT TO GET YOUR FINGERS AND HANDS CRUSHED.

9.3 ASSEMBLY OF THE ADDITIONAL SIDE PLATES

ADDITIONAL SIDE PLATES FOR GRAIN SIDE PLATES

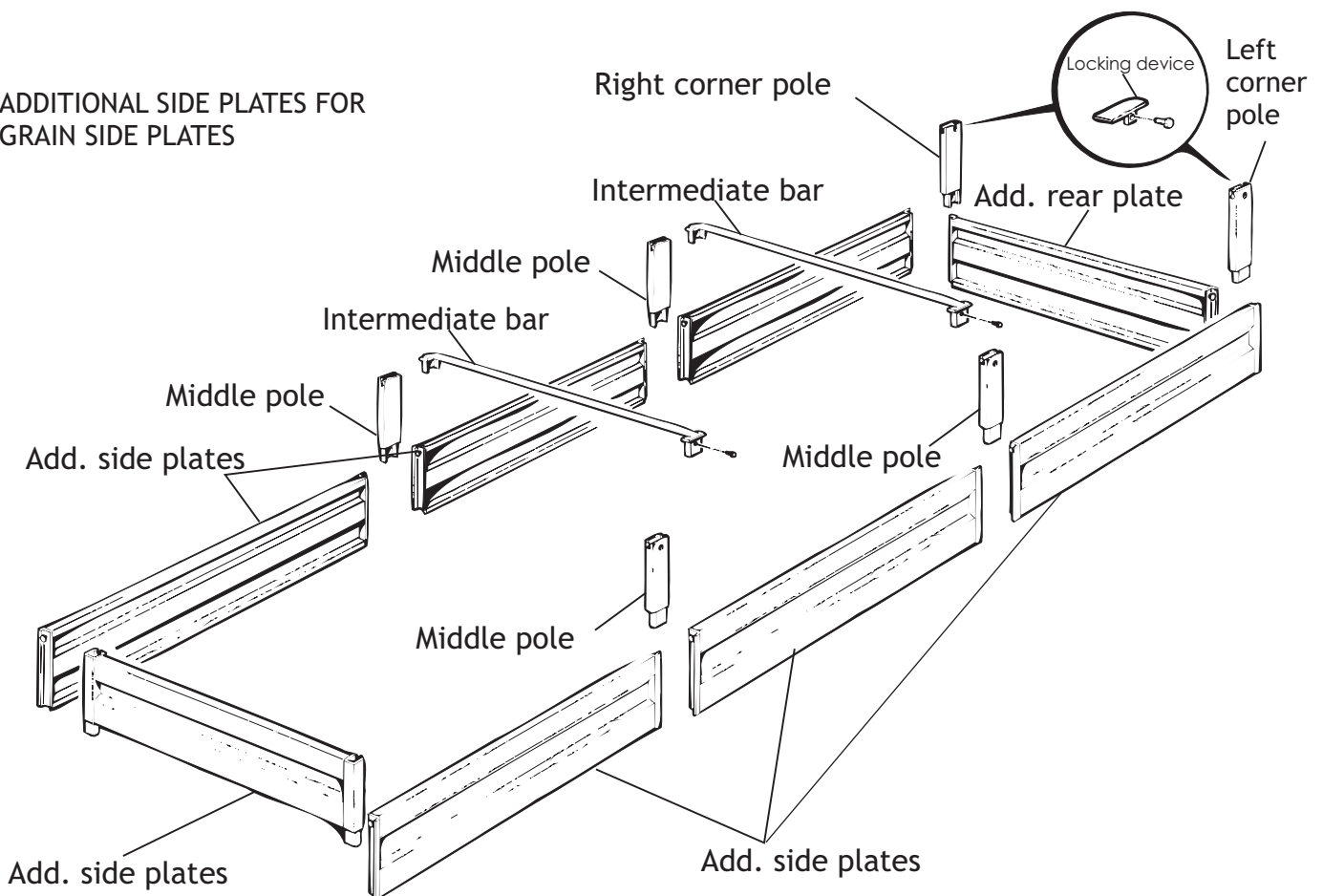

1. First install the additional front plate.
2. Put the extensions of the middle poles in place. (Remove the middle bar from the grain side plate middle poles.)
3. Install the extension of the right and left rear corner pole on top of the old ones. Take into consideration the attachment slots required by the side plates.
4. Lift the additional rear plate to its place.
5. Place the additional side plates.
6. Install the middle bar on the middle poles and lock it with screws.
7. Lock the side plates and rear plate with the locking device. See the picture on the previous page.
8. Attach the intermediate chain to the grain poles.

Additional side plates installed in place

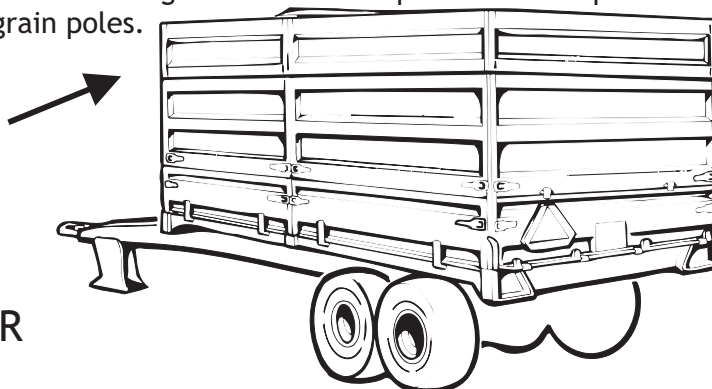

9.4 ATTACHING TO A TRACTOR

The trailer is connected to the tractor towing hook (ISO 6489/1). If the tractor includes an automatic towing hook, secure the connection.



NOTE! CONNECTING AND DISCONNECTING THE TRAILER MAY BE DANGEROUS. THE TRAILER MAY BE LOADED SO THAT THE SHAFT WEIGHT IS NEGATIVE; OR IT MAY BE SO LARGE THAT THE CARRYING CAPACITY OF THE CHASSIS IS EXCEEDED.

HYDRAULICS

The J16JL trailer needs 1 single-function hydraulics output equipped with a quick coupling according to standard ISO 7241-1. Trailer J16JLD needs 1 single-function and 1 dual-function hydraulics output.

INSTALLATION

NOTE! DURING INSTALLATION THE PLATFORM MUST BE IN THE LOWER POSITION.

TAKING INTO USE

We recommend that if the trailer is used with more than one tractor, that you use the same type of oil, because when used the oils will mix together.
The hydraulics oil filled at the factory is NESTE 32.

USE

The tipper hose is connected with a quick coupling. The end of the hose is connected normally to the tractor. After this the trailer can be used normally as a tipper trailer with the tractor hydraulics.



NOTE! HYDRAULICS HOSES CANNOT BE DISCONNECTED FROM THE TRACTOR, THE TIPPING CYLINDERS OR CONNECTORS WHEN THE PLATFORM IS RAISED.

It is recommended that the hydraulics of the loaded trailer is not disconnected from the tractor, even if the platform is in the lower position. Pressure may remain in the system due to the trailer's structure. Pressure can be removed so that you may drive with the trailer while keeping the tipping lever in the down position.



PRESSURISED HOSES CAN NEVER BE EMPTIED BY RUBBING OR PRESSING ON THE QUICK COUPLING, BECAUSE THERE IS ALWAYS A DANGER OF PERSONAL INJURY AND SOIL CONTAMINATION.

DO NOT EXCEED THE MAXIMUM PRESSURE OF THE HYDRAULICS SYSTEM, 210 bar.

LIGHT DEVICES

Light devices are connected to the trailer connecting terminal of the tractor. The connecting terminal must be 7-pin according to standards SFS 24272 and DIN ISO 3732. The light devices work with direct current with the nominal voltage of 12V.

BRAKES

Compatibility with the tractor

Generally, modern tractors have the ability to use the trailer's brakes with the tractor's own brake system. In these cases the tractor must include its own brake block and output connector for the trailer brakes. This equipment are usually accessories, so for a standard agricultural tractor they must be ordered either at the time of purchase or later as a separate accessory package.

The brake pressure the tractor provides usually depends on the pedal power; in a tractor the maximum limit is 150 bar.

In this case the compatibility depends on the relative pressure difference between the tractor and the trailer.

In tractors where the trailer brake pressure can be selected, the pressure difference is given as ratios, e.g. 1/5.44. The ratio means that the trailer brake system has 5.44-times the pressure of the tractor brake system. In these systems the maximum pressure produced by the tractor is usually also limited to 150 bar.

A suitable brake ratio depends on the use of the trailer, but generally a fairly low ratio is the best. In practice this means that the brake pedal power must be fairly large to achieve maximum pressure.

The trailer brakes can be used also through the tipper hydraulics.

To function, the brake needs one single-function hydraulics output equipped with a connector according to standard ISO-7441-1.

The system pressure is limited to 120 bars with a pressure regulation valve sold as an accessory. Keep in mind that using brakes on general roads requires that the trailer brake lights function simultaneously with the brakes.

10 CHECKS

- ✎ Check the tyre pressures regularly.

Tyre	Pressure kPa
560/45 R 22.5 146D ELS TL	320
600/50 R 22.5 156D ELS TL	360

- ✎ Check that the oil hose connectors are compatible with the tractor. The trailer includes an Aeroquip ½" connector.
- ✎ Check the functioning of the lights. The rear, indicator and brake lights are connected according to a European standard. If the lights do not function correctly in the check, make sure that the tractor electric output has been connected according to the standard.
- ✎ Before using, the platform must be tipped when empty 2-3 times. The tipping cylinder has been test-pressurised on the factory, after which the oil has been removed.
- ✎ Check the tightness of the wheel nuts and screws (about 400Nm=40kpm) after three hours of driving. Re-check 2-3 times a year depending on the use. See the picture below.
- ✎ Tighten all screws and nuts twice during use season.
- ✎ Check the compatibility of the tractor brake output with the trailer if the tractor includes a separate brake output hydraulics.

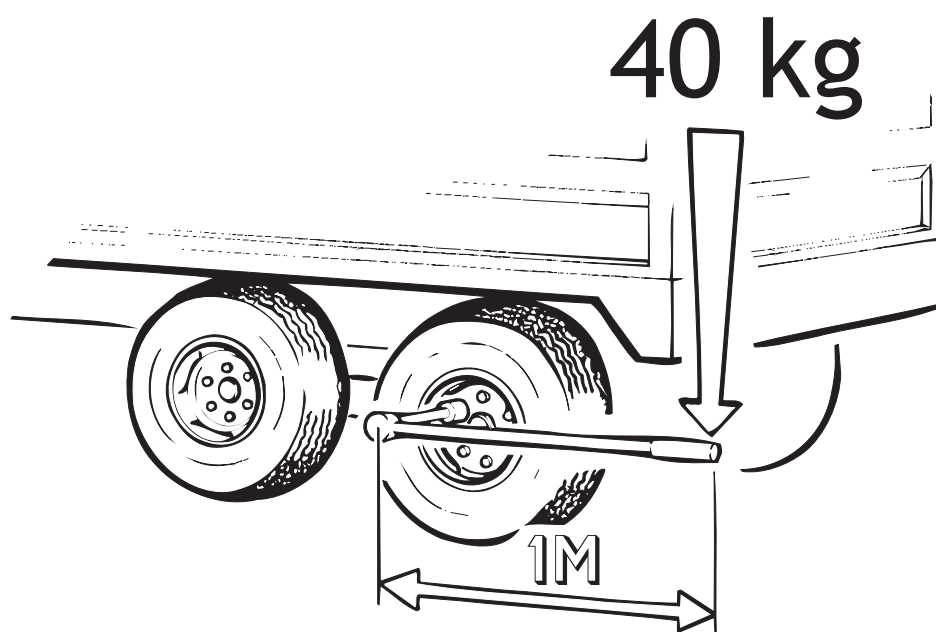

TIGHTENING THE WHEEL BOLTS

11 LOADING

1. Take into consideration the trailer carrying capacity and the road legislation, because then the warranty is also valid.

NOTE! THE TABLE 1 IS REFERENTIAL.

TABLE 1.

MATERIAL	VOLUME PP .. Kg/m	ALLOWED HEIGHT OF THE LOAD cm
FERTILIZER	1100	98
SAND	1500 - 1900	57- 72
CLAY	1700 - 2000	54 - 63
ROCK	2200 - 3000	36 - 49

2. Always make sure the load is fastened and stays on the platform. The load and its transporting are always the driver's responsibility.

12 USE

WHEN THE TRAILER IS UNLOADED, FAMILIARIZE YOURSELF WITH ITS FUNCTIONS. MAKE SURE THAT THE TIPPING IS ALWAYS SUFFICIENTLY HARD AND STRAIGHT (NOT SLANTED).

12.1 NORMAL TIPPING

Be careful not to damage the rear plate. This can occur due to the large tipping angle. The tipper can be used only when no one is on the tipping area and when there is no strong side wind during the tipping. The tipper is allowed to be used only with the controller at the driver's seat. In addition such hydraulics output of the tractor must be used which can be controlled with a positive driven controller. THE REAR PLATE MUST ALWAYS BE OPENED BEFORE TIPPING! When tipping moist grain, you must open both rear plates (grain platform).

WHEN TIPPING, THE TRAILER MUST ALWAYS BE CONNECTED TO THE TRACTOR.



THERE IS ALWAYS A DANGER IF THE TRAILER IS MOVED WHEN THE TIPPER IS UP.

PAY ATTENTION TO THE RISKS INVOLVED WHEN TIPPING IN A LOCATION WHERE THERE IS AN ELECTRIC WIRE (OR SOME OTHER LIMITING BLOCKAGE) ABOVE THE TRAILER.

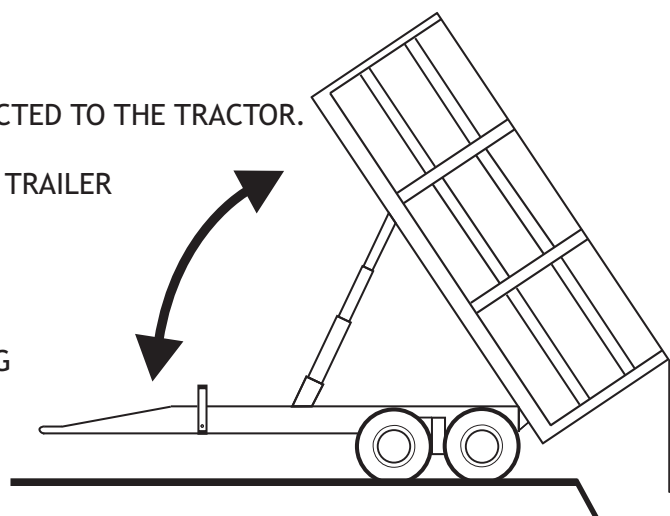

12.2 LOWERING THE PLATFORM

Lowering takes place in reverse order. If the service support has been raised, lower it. When lowering the platform, always make sure that there is nothing between the platform and the body, which would cause a danger or injury.

13 SERVICE

13.1 LUBRICATION DIAGRAM

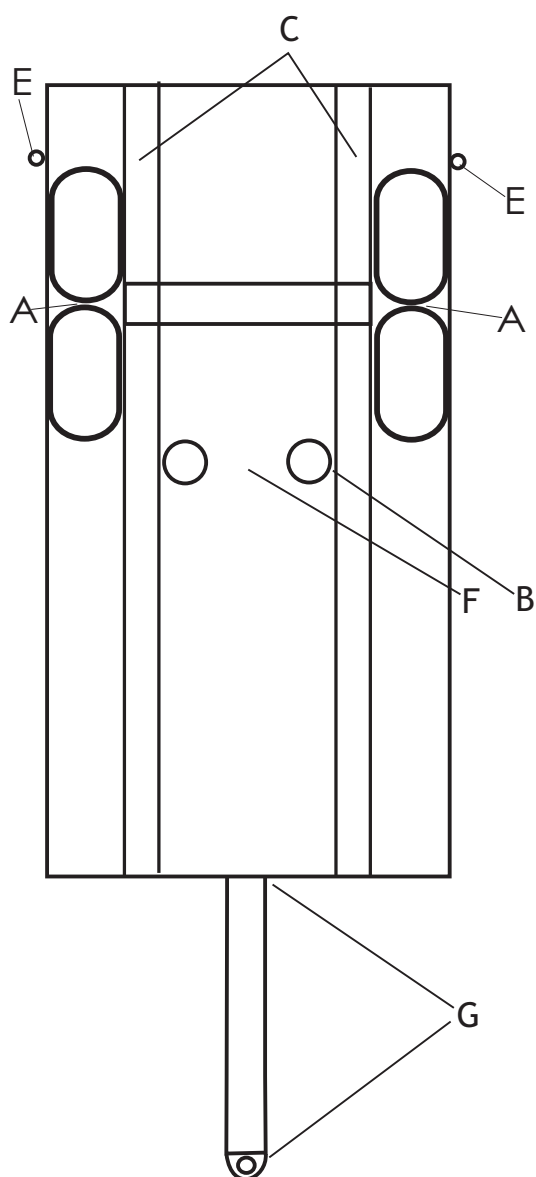

TARGET	LUBRICANT	SERVICE INTERVAL
A. BOGIE SWING AXLE	VASELINE	500 h
B. HYDRAULICS	HYDRAULICS OIL SAE20 WTAI SAE 10 W	See section 13.2
C. SWINGING HINGE	VASELINE	Once a week
D. PLATFORM LOCKS (J16JLV)	CRC OR CORRESPONDING.	Use-seasonally 2-4 times
E. REAR PLATE CYL. ARTICULATION BEARINGS (J16JLD)	VASELINE	Use-seasonally 2-4 times
F. TIPPER PLATE	VASELINE	Platform change
G. DRAWBAR	VASELINE	500 h

LUBRICATION INSTRUCTIONS

When lubricating, you must make sure that the lubricant goes to the correct location. For example: when greasing the articulation bearings of the bogie swings, the trailer must first be lifted (e.g. 10cm) off the ground so that the grease goes to the pressurized sliding surfaces. When greasing the articulation bearings, the bogie swing must be swung periodically.

13.2 HYDRAULICS MAINTENANCE

Check the oil amount in the tractor after the first lifting and tipping and add oil if needed. During the first lifts, the cylinder may let out some oil to the cylinder surface; this is perfectly normal, and will disappear with time when the seals are honed to form.

13.3 ADJUSTING THE BRAKES

The brakes must be adjusted once per use season or as needed. The brakes are adjusted by turning the brake lever in the brake axle in the following way:

- A) Remove the fastening pin of the brake cylinder piston arm.
- B) Remove the brake lever.
- C) Turn the brake lever with the brake axle boron so that when braking, the free movement at the end of the brake lever is about 4cm.
- D) Lift the wheel into the air and, by turning with both hands, make sure that the brakes are not "on."

13.4 ADJUSTING AND TIGHTENING THE HUB

The castle nut is tightened until the hub no longer rotates by hand. After this, the nut must be loosened by one fifth of a turn. Then put the cotter pin in the slot nearest to the castle nut. Check that the wheel rotates freely by rotating by hand.

With the calculated loads, a suitable bearing clearance is 0.05-0.15mm.

Pay attention to the possible heating of the bearing during the first kilometres of driving; check the clearances after driving for three hours. Adjust when needed.

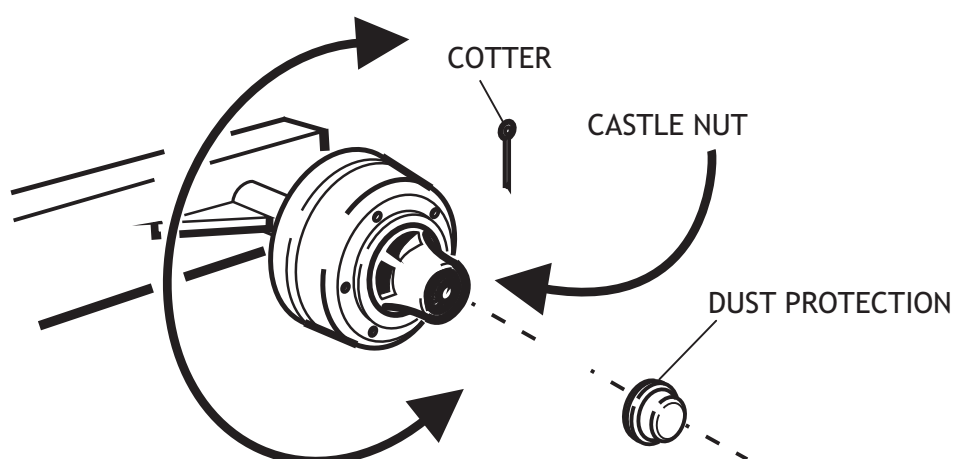

14 REMOVING THE PLATFORM

The trailer is structured so that the **empty** platform can be left supported by the legs. It is extremely important that you work in the order given in the instructions when removing the platform because the work is dangerous. The structure of the trailer is designed so that changing the platform takes place a few times per year. An experienced user will spend about one hour to change the platform.

You must always remember stay out from under a lifted platform, unless the platform support or legs have been installed to support the platform!

1. Store the platform in a hard-base and dry location where the soil will not soften even during hard rains and frost. Note: Never leave the platform on a slope in a cross direction, as the platform may fall. The location must be such that when looking from the back, the platform is straight.
2. Remove the hydraulics quick couplings of the rear plate (under the dumper platform at the back of the trailer).
3. Lift the empty platform by tipping it to about a 10o angle. The space between the platform front and body should then be about 93cm.
4. Lower the tractor drawhook to its lowest position, so that the trailer drive link lowers to about 15 cm from the ground. The trailer front lowers more and the back raises a little.
5. Put plates at the leg positions on the ground. A suitable plate is veneer of size 15x400x400mm or a steel plate of size 6x400x400mm. These stop the legs from pressing into the ground.
6. Install the legs in the pipe beams on the platform. Adjust the threaded screws of the leg's lower ends so that 1cm of the thread remains visible. A rough adjustment of the leg length should be done so that the peg is placed in the lowest possible hole.
7. Screw the threaded screws so that each leg takes an even amount of the load.
8. Remove the locking pegs from the upper end of the tipper.
9. Lift and lower the tractor drawhook a few times, after which the tipping cylinders should come out of the cradle at the bottom of the platform. If the cylinders do not easily come out of the platform cradle, bar off the tipping plate at the upper end of the cylinders away from the hole flats. The cylinders must be removed completely from the platform.
10. Remove the locking plates from the swing hinge.
11. Lift up the tractor drawhook and drive the trailer base away carefully.

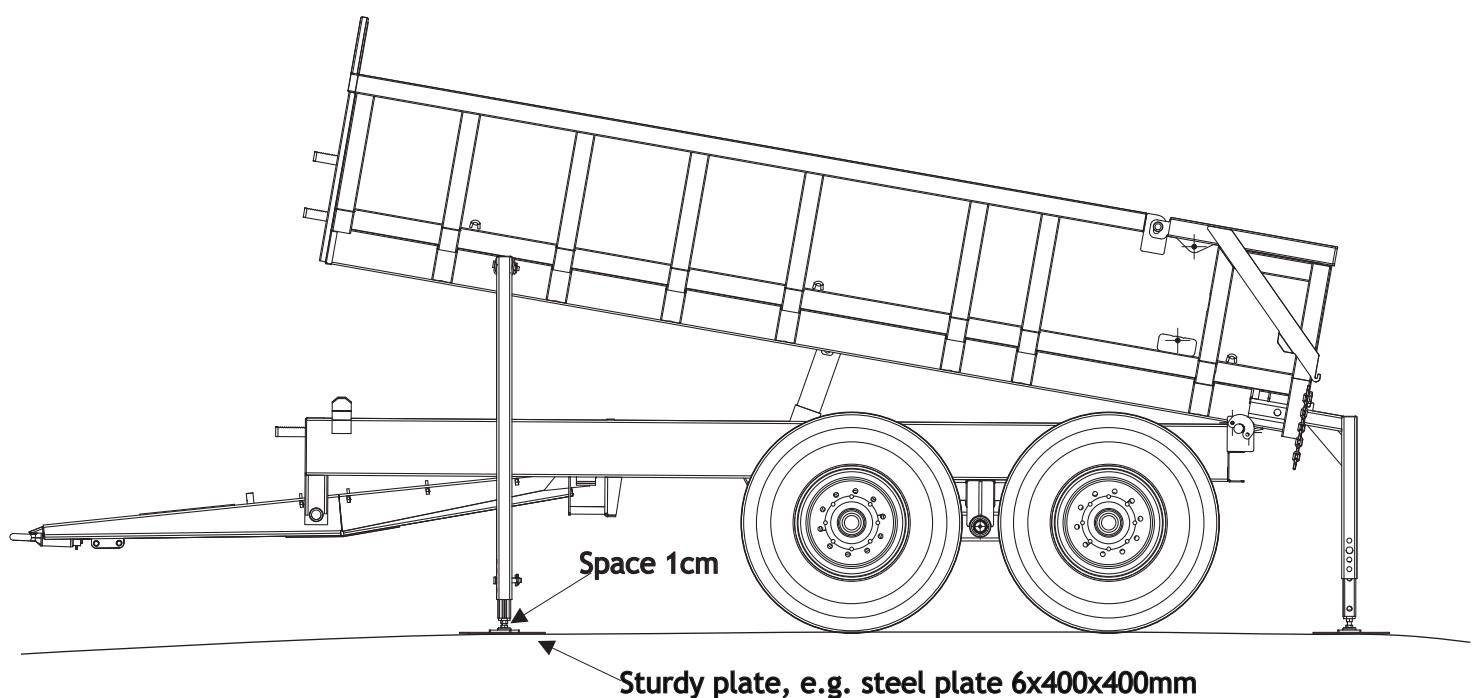

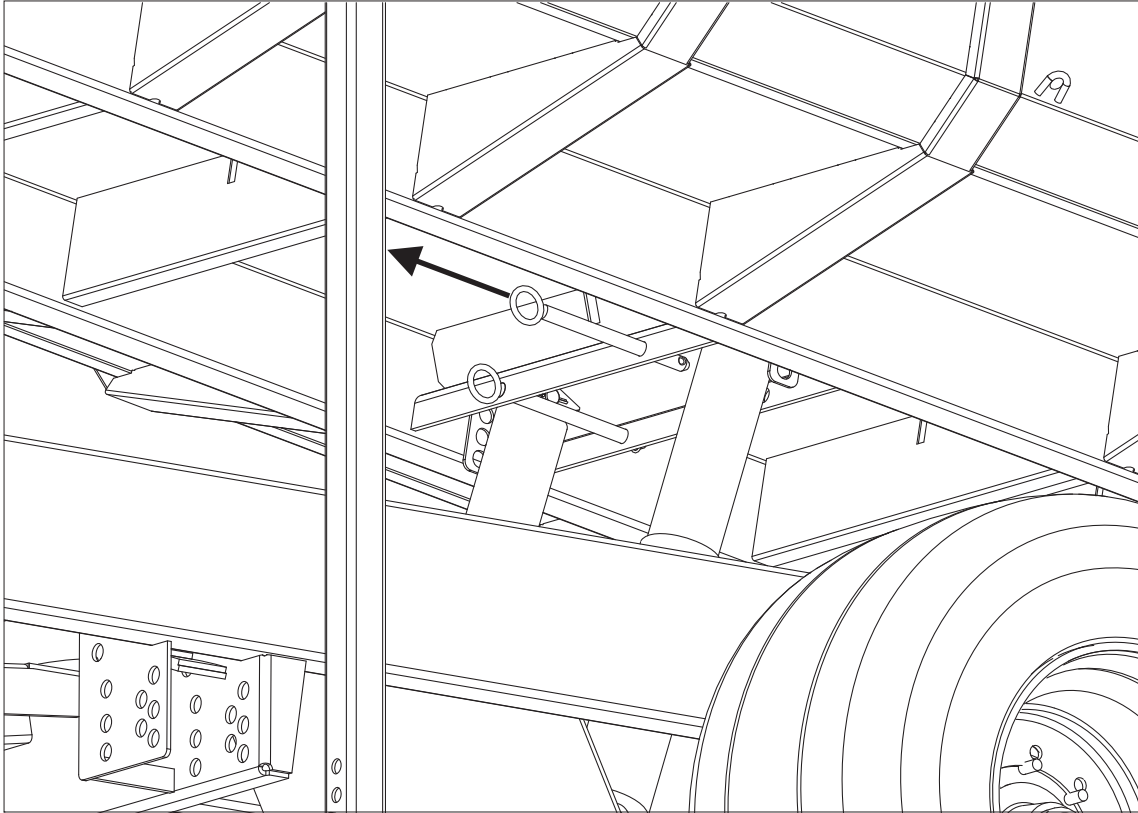

Removing the locking pins at the upper end of the tipper.

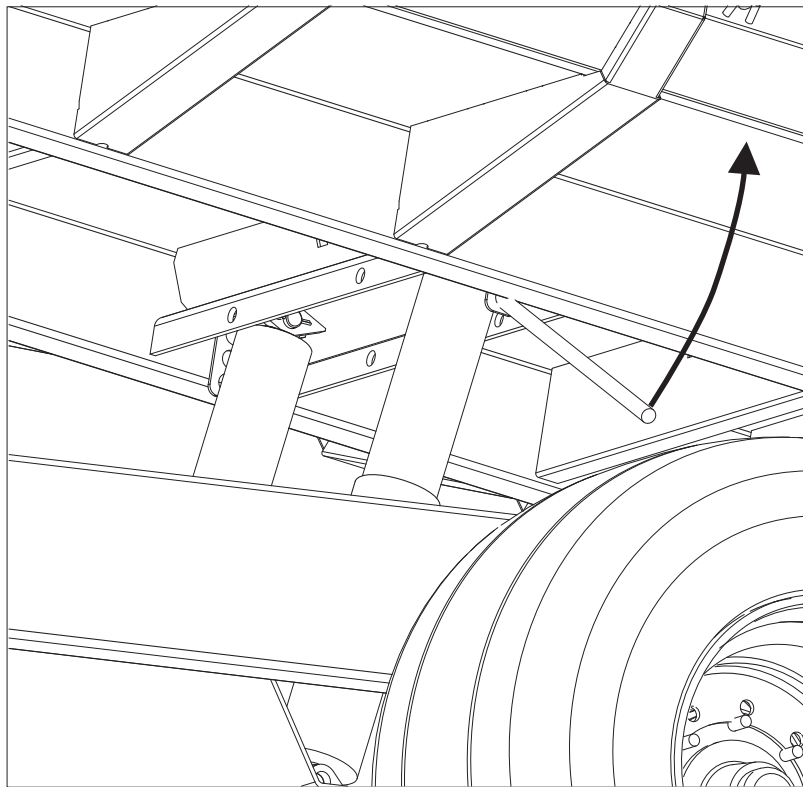

When barring off the tipper plate of the upper end of the tipper, be careful not to scratch the cylinder.

2:1

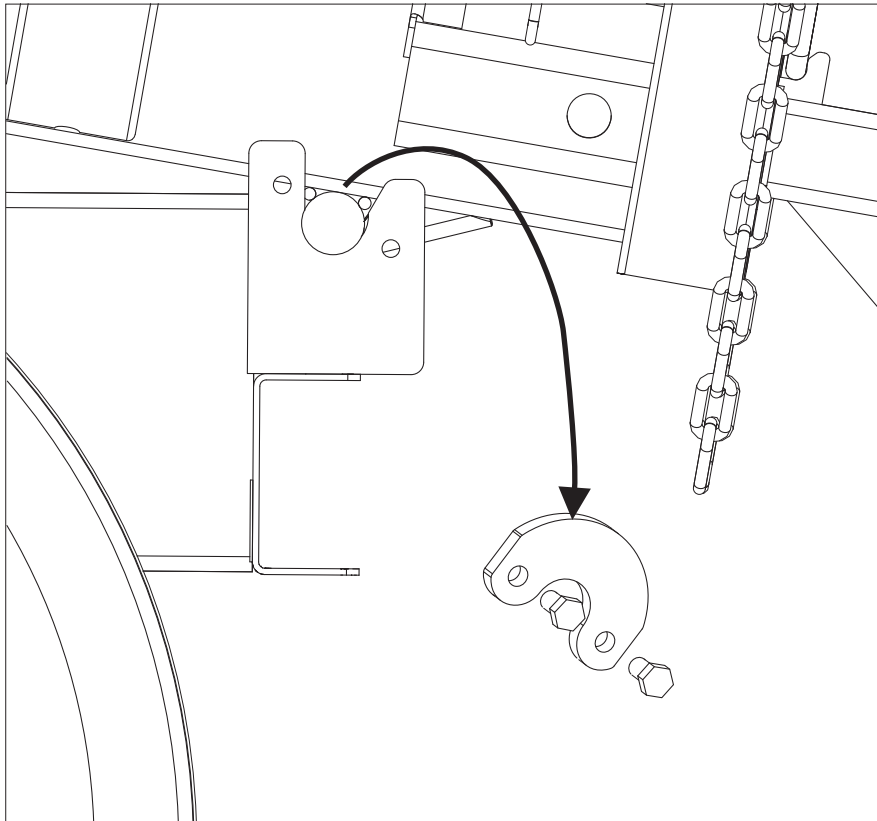

Removing the locking plates swing hinge.

Lavan irrotus järjestys
Ordning för lösgörande av flak
Order for platform detachment

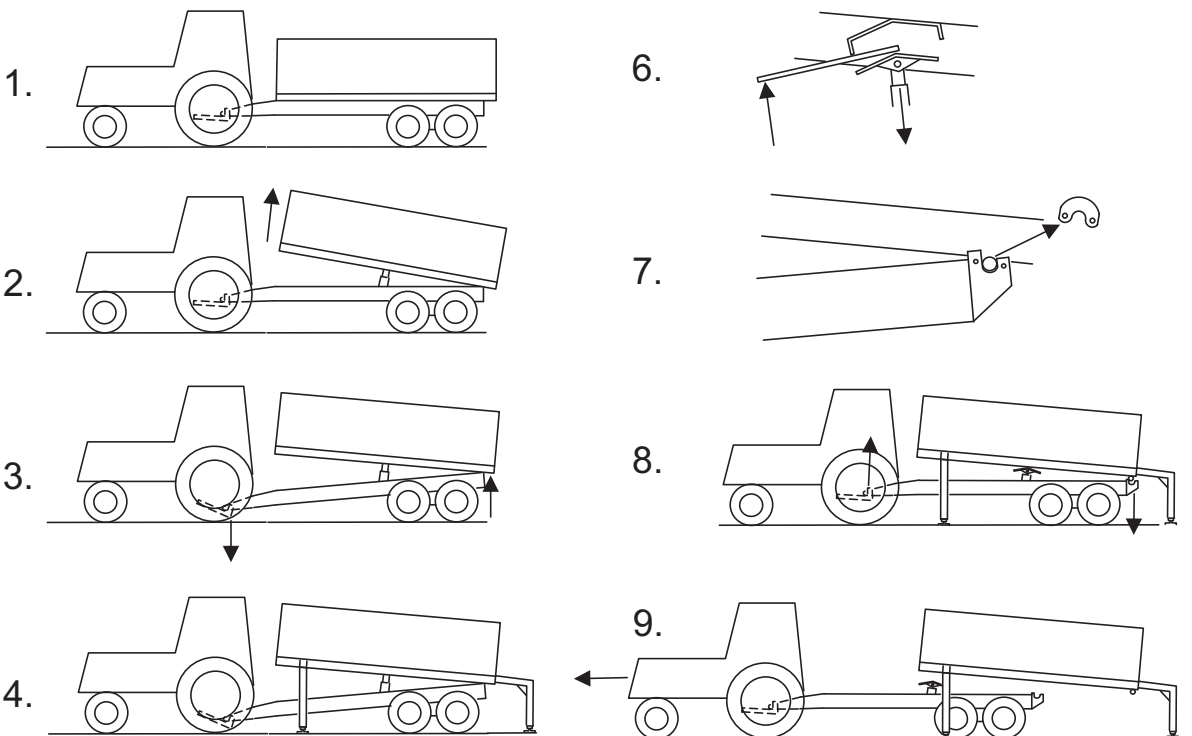

26537

15 REMOVING THE PLATFORM

If the platform has been on its legs (e.g. over winter), you must first check that the platform is in a good position. If the platform is slanted, you must straighten it by adjusting the legs.

1. Back the trailer base carefully under the platform standing on its legs.
2. When you have succeeded to back the base to the correct location, so that the slots of the body's back end are at the swing axle, then lower the tractor drawbar. Then the back end of the trailer rises higher and the swing axle goes into the slots on the body.
3. Attach the locking plates of the swing hinge.
4. Lift the tipping cylinders carefully to the cradle on the bottom of the platform so that the tipper plate of the upper ends goes to the bottom, but does not yet lift the platform.
5. Install the locking pins of the tipper upper end.
6. Lift the tipper about 3cm higher. Then remove the front legs from the platform.
7. Lower the tipper and then remove the back legs.
8. Connect the quick couplings of the rear plate hydraulics (under the dumper platform at the back of the trailer).
9. Grease the swing hinges and lubricate the moving parts of the legs.
10. Move the legs and base plates to a dry storage location.

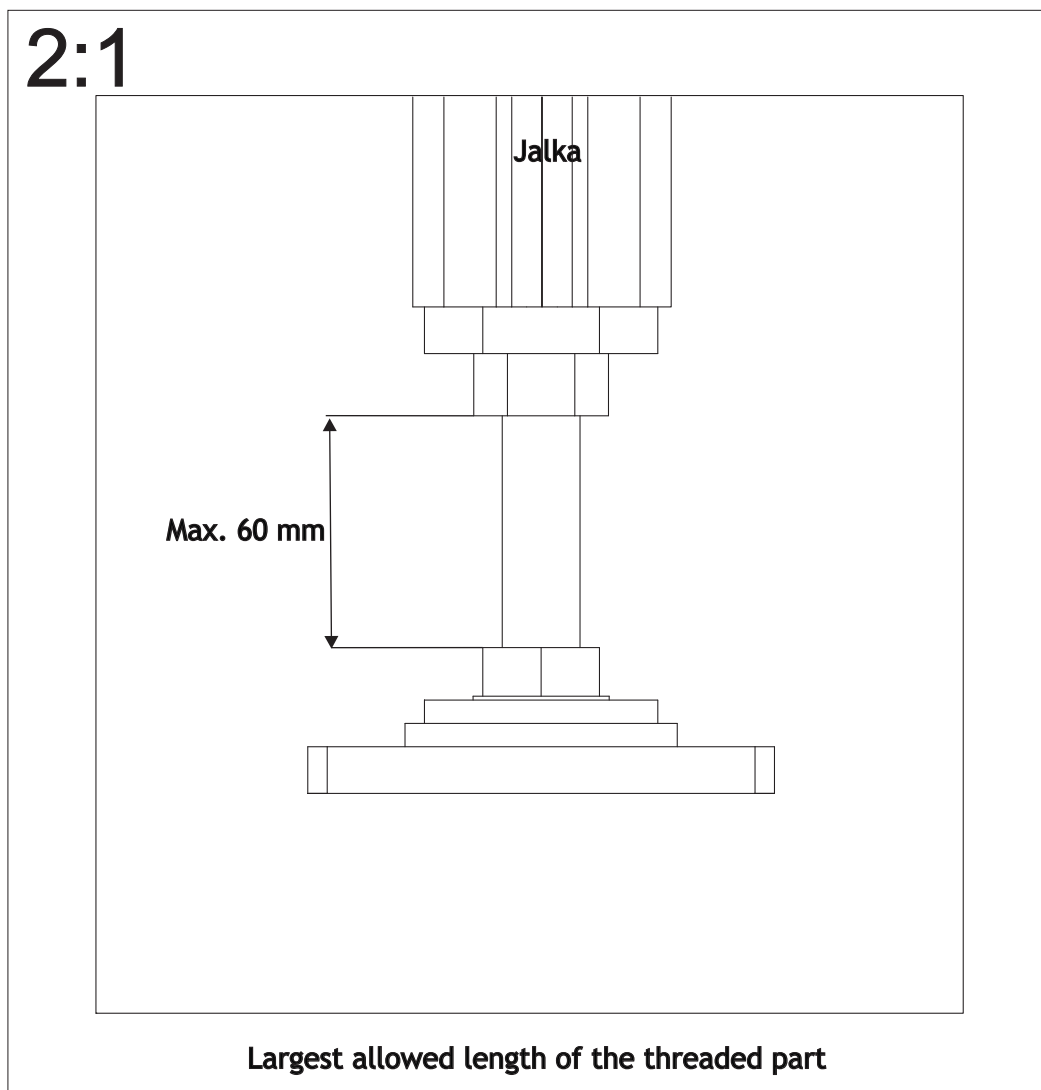

16 TROUBLESHOOTING DIAGRAM

FAULT	CAUSE	ACTION	NOTES
The hydraulics hoses do not come loose from the connectors	Hydraulics system pressure	Remove the pressure from the system	First close the possible ball faucets (J16JLD)
Hub heats up	Bearing damaged, little grease in the hub, the hub is too loose/tight	Change the bearing when necessary. Lubricate the hub Adjust the tightness of the hub	See hub adjusting-instructions
The platform lowers with jerks	Air in the tipping cylinders	No actions needed	Air is removed with use over time from the hydraulics system
The tipper does not rise	The quick coupling of the tipper hose is not compatible with the tractor connector.	Change the quick coupling to a suitable one	Standard quick couplings are not necessarily compatible with each other, even though the couplings would attach to each other.
The tipper rises a little or badly.	There is little hydraulics oil leaks in the system	Check that there are no leaks in the hydraulics system. Also check the tractor hydraulics and the amount of hydraulics.	
The platform lowers very slowly	The tractor hydraulics uses other hydraulics as well (e.g. hydraulics switch etc.)	No actions needed	Counter-pressure is formed in the hydraulics hose from the tractor.
The platform will not lower	Hose breakdown valve is working Quick coupling is damaged	Check the condition of the hoses. Change the quick coupling	Platform lowers at too great-Speed. Choke the oil return flow

The normal wearing of the tipper trailer takes place safely and does not cause dangerous situations.



You must take into consideration that if the machine is used against traffic rules and safety instructions, or if the machine is overloaded and not serviced, there is always a danger of unusual wear or breakdown that may harm both people and the environment.

17 WITHDRAWING THE PRODUCT FROM USE

READ SAFETY INSTRUCTIONS



Withdrawing the product from use is the responsibility of the end user of the product or the person or company that owns the product when it is decommissioned.

There are national laws, instructions and regulations regarding decommissioning the product and handling the different waste created, and these all must be followed.

Most parts of the trailer are non-decomposing materials, so the trailer must be disassembled and the different materials discarded according to national regulations.

- ✍ Iron and other metals are recycled through machine and device scrapping companies to be re-used.
- ✍ Waste oil, plastic and rubber parts other than tires are handled as problem waste and should be discarded either by recycling or by appropriately transporting them to a dump yard or discarded otherwise according to national regulations.
- ✍ Tyres must be discarded according to directives 83/189EEC, 182/88/EEC, 94/10/EU by taking the used tyres to recycling points or to recycling operators that deliver the tyres forward to be re-handled.

If needed, you can get additional information on disassembly and waste handling from the environmental authorities.

18 TERMS OF WARRANTY

- ✍ The warranty period is 12 months of agricultural use in the work that the device has been meant for.
- ✍ In a communal, industrial and professional contracting or corresponding use, the warranty time is 6 months.
- ✍ The warranty time begins when an authorised reseller delivers the new device.
- ✍ The warranty will cover manufacturing and material errors. The damaged parts are repaired or replaced to usable ones at the factory or at an agreed repair shop. The subcontracted parts have a guarantee given by their manufacturers.
- ✍ Warranty repair does not continue the warranty period.

The warranty will not cover damages that are caused by erroneous use against the instruction manual or by erroneous service, excessive loading or normal wear. The warranty will not cover any consequential damage, days of stoppage, travel expenses, cargo payments, daily allowances, overtime work or changing the original structure of the machine.

For warranty issues we recommend that you turn to the sales point, who will then make a warranty claim. Before taking any action, the actions and their possible costs must be agreed upon beforehand with the manufacturer.

The warranty is valid only if the warranty card is returned appropriately filled to the manufacturer within 14 days of date of delivery.

19 RESPONSIBILITY AREAS

The manufacturer is not liable if the machine is used against laws, safety instructions or this manual. When using the machine, situations may occur that do not have related instructions or regulations; therefore, the user is recommended to act accordingly to common machine safety instructions and directives.

The manufacturer is not responsible for any damage caused by using components made by other manufacturers.

The manufacturer is not responsible for any damage caused to other machines or devices by using the trailer.

The manufacturer is not responsible for any damage caused by incorrect fodder.

The manufacturer is not responsible for damage caused by foreign objects and overfilling.

The manufacturer reserves the right to further develop or change the machine structure.

EY -VAATIMUSTENMUKAISUUSVAKUUTUS KONEESTA**(FI)**

Valmistaja Junkkari Oy
Osoite Pohjanmaanväylä 5, FIN-62375 YLIHÄRMÄ

Vakuutamme yksinomaan omalla vastuullamme, että markkinoille saatettu kone

JUNKKARI J16

valmistenumeroista **101** alkaen on soveltuville osin rakennettu normatiivisten asiakirjojen ohjeiden mukaan ja noudattaa direktiivien 98/37/EY määräyksiä

EG- FÖRSÄKRAN OM ÖVERENSSTÄMMELSE FÖR MASKINELL UTRUSTNING**(SE)**

Tillverkare Junkkari Oy
Adress Pohjanmaanväylä 5, FIN-62375 YLIHÄRMÄ

Försäkrar härmed enbart på vårt eget ansvar, att för marknader tillverkad maskin

JUNKKARI J16

f.o.m tillverkningsnummer **101** är tillverkad i tillämpig mängd i överensstämmelse med instruktioner av det normativa dokumentet följer bestämmelser av följande direktiver: 98/37/EY

EC DECLARATION OF CONFORMITY FOR MACHINERY**(EN)**

Manufacture Junkkari Oy
Address Pohjanmaanväylä 5, FIN-62375 YLIHÄRMÄ

Herewith declare on our sole responsibility that for the market produced machine

JUNKKARI J16

from the manufacturing number **101** is manufactured, where applicable, in conformity with provisions of the instructions of the normative document according to the following directive: 98/37/EY

DECLARATION CE DE CONFORMITE POUR LES MACHINES**(FR)**

Fabricant Junkkari Oy
Adresse Pohjanmaanväylä 5, FIN-62375 YLIHÄRMÄ

Certifions á nos propres risques, que la machine suivante commercialisée

JUNKKARI J16

et ce depuis le numéro de série **101** est en conformité avec les normes applicables et les dispositions de la directive 98/37/EY

EG-KONFORMITÄTSEKTLÄRUNG FÜR MASCHINEN**(DE)**

Hersteller Junkkari Oy
Adresse Pohjanmaanväylä 5, FIN-62375 YLIHÄRMÄ

Erklären hiermit ausschließlích auf eigene Verantwortung, daß die Maschine

JUNKKARI J16

von der Herstellungsnummer **101** konform mit den einschlägigen Bestimmungen von dem normativen Document hergestellt ist und Bestimmungen von Direktiven: 98/37/EU

EC SAMSVÆRSERKLÆRING OM MASKINER**(NO)**

Produsent Junkkari Oy
Adresse Pohjanmaanväylä 5, FIN-62375 YLIHÄRMÄ

Erkærer at produktet beskrevet heretter

JUNKKARI J16

f.o.m Tillverkningsnummer **101** Som omfattes av denne erklæringen, er i samsvar med instruksjonene i dokument samt bestemmelsene i følgende direktiv: 98/37/EY.

Declaration of Conformance to EU

TOEND MASINA NOUTELEVASTAVUSE KOHTA

(EE)

Valmistaja Junkkari Oy
Aadress: Pohjanmaanväylä 5, FIN-62375 YLIHÄRMÄ

Kinnitamme ainuüksi omaenda vastutus el, et turule lastud masin

JUNKKARI J16

valmistusnumbrid 101 on ehitatud normatiivsete dokumentide juhiste kohaselt ja vastab direktiivi 98/37/EY nõustele

ZAPEWNIENIE ZGODNOSCI URZADZENIA Z WYMAGANIAMI

(PO)

Producent Junkkari Oy
Adres: Pohjanmaanväylä 5, FIN-62375 YLIHÄRMÄ

Zapewniamy wyłacznie na własna odpowiedzialnosc, ze wprowadzona do sprzedazy

JUNKKARI J16

począwszy od nr fabrycznego 101 jest skonstruowana w zakresie stosowalnosci zgodnie z normatywna dokumentacja i przepisami dyrektywy: 98/37/EY

CEE DECLARACIÓN DE CONFORMIDAD PARA MAQUINARIA

(ES)

Fabricante: Junkkari Oy
Dirección: Pohjanmaanväylä 5, FIN-62375 YLIHÄRMÄ

Declara en su misma responsabilidad que la máquina construida modelo:

JUNKKARI J16

con el numero de fabricación 101 está fabricada con conformidad a las prescripciones de la normativa referente a la siguiente directiva: 98/37/EY

Ylihärmässä 24.10.2007



Arto Aro
Tekninen Johtaja
Technical Director