

Junkkari



A GOOD WAY TO WORK HARD

**VARAOSAKIRJA
SPARE PARTS CATALOGUE
JUNKKARI S-M-D
COMBI DRILLS**

2015-2016

SISÄLLYSLUETTELO

1.	SÄILIÖ	6
1.1	SÄILIÖ SMD, LANNOITE SAMAA RIVIIN	6
1.2	KONEISTO SMD, LANNOITE SAMAA RIVIIN	10
1.3	SÄILIÖ SM, LANNOITE ERI RIVIIN	13
1.4	KONEISTO SM, LANNOITE ERI RIVIIN	16
1.5	SÄILIÖ SMD, SEED	18
1.6	KONEISTO SMD, SEED	20
1.7	VAIHDELAATIKKO, SIEMEN	22
1.8	VAIHDELAATIKKO, LANNOITE	23
1.9	MAAPYÖRÄ	24
1.10	SYÖTTÖKOTELO, SIEMEN	26
1.11	SYÖTTÖKOTELO, LANNOITE	27
1.12	RUISKUTUSURAKYTKIN	28
2.	RUNKO JA VANTAAT	30
2.1	RUNKO S, LANNOITE ERI RIVIIN	30
2.1.1	LANNOITEVANNAS, S-PIIKKI	32
2.1.2	LANNOITEVANNAS, S-KAKSOISKIEKKO	33
2.1.3	LANNOITEVANNAS, KUMIPATUKKA	34
2.2	RUNKO S, COMBI	36
2.3	RUNKO S, SEED	38
2.4	SIEMENVANNAS S	40
2.5	VANNASPAINATUKSEN KESKUSSÄÄTÖ S, MEKAANINEN	41
2.6	VANNASPAINATUKSEN KESKUSSÄÄTÖ S, HYDRAULINEN	42
2.7	RUNKO M, LANNOITE ERI RIVIIN/SEED	44
2.7.1	LANNOITEVANTAISTO M	46
2.7.2	LANNOITEVANNAS M	48
2.8	RUNKO M, COMBI	50
2.9	SIEMENVANNAS M	52
2.10	VANNASPAINATUKSEN KESKUSSÄÄTÖ M	53
2.11	RUNKO D	54
2.11.1	VANNAS D	56
2.12	VETOLAITE S	58
2.13	VETOLAITE SMD	60
3.	JYRÄPYÖRÄSTÖ	62
3.1	JYRÄPYÖRÄSTÖN RUNKO SMD	62
3.2	JYRÄPYÖRÄSTÖN KEINU SMD	64
3.3	JYRÄPYÖRÄSTÖN SYLINTERI JA HUOLTOTUKI	66
3.4	JÄLKIHARA SMD	68

4.	AJOTIETOKONE	70
4.1	KOMPONENTIT	71
4.2	PINTA-ALAMITTARI	72
5.	VETOAISA	73
5.1	VETOAISA S, VETOKOUKULLE	73
5.2	VETOAISA S, VETOKIDALLE	73
5.3	VETOAISA S, PAKKERILLE	74
5.4	VETOAISA SMD, VETOKOUKULLE	75
5.5	VETOAISA SMD, PAKKERILLE	76
5.6	VETOAISOJEN LETKUTUKSET	77
5.7	PAKKERI PIENI SMD	78
5.8	PAKKERI ISO SMD	80
6.	LISÄVARUSTEET	82
6.1	ETULATA SMD, 1-RIVINEN	82
6.2	ETULATA M, 1-RIVINEN, ERILLISET LANN. VANTAAT	84
6.3	ETULATA MD, 2-RIVINEN	86
	S-PIIKKIMUOKKAIN MD, 2-RIVINEN	86
6.4	KIEKKOMUOKKAIN MD	88
	6.4.1 KIEKKOMUOKKAIN	90
6.5	RIVIMERKITSIN SMD	92
6.6	RIVIMERKITSIMEN PÄÄ	95
6.7	PIENSIEMENLAITE SMD, SÄILIÖ	96
6.8	PIENSIEMENLAITE SMD, KONEISTO	98
6.9	SIEMENSEULAT SMD	100
6.10	PUOLENKONEEN SULKU	101
6.11	LISÄOSAT KULJETUSTA VARTEN SMD	102

CONTENTS

1.	HOPPER	6
1.1	HOPPER SMD, FERT INTO THE SAME ROW	6
1.2	GEAR SMD, FERT INTO THE SAME ROW	10
1.3	HOPPER SM, FERT INTO A SEPARATE ROW	13
1.4	GEAR SM, FERT INTO A SEPARATE ROW	16
1.5	HOPPER SMD, SEED	18
1.6	GEAR SMD, SEED	20
1.7	GEARBOX, SEED	22
1.8	GEARBOX, FERTILIZER	23
1.9	FRICITION WHEEL	24
1.10	FEEDING HOPPER, SEED	26
1.11	FEEDING HOPPER, FERTILIZER	27
1.12	TRAMLIN SWITCH	28
2.	FRAME AND COULTERS	30
2.1	FRAME S, FERT INTO A SEPARATE ROW	30
	2.1.1 FERT COULTER, S-TINE	32
	2.1.2 FERT COULTER, S-DOUBLE-DISC COULTER	33
	2.1.3 FERT COULTER, RUBBER STICK	34
2.2	FRAME S, COMBI	36
2.3	FRAME S, SEED	38
2.4	SEED COULTER S	40
2.5	CENTRAL ADJUSTMENT OF THE COULTER PRESSURE S, MECHANICAL	41
2.6	CENTRAL ADJUSTMENT OF THE COULTER PRESSURE S, HYDRAULIC	42
2.7	FRAME M, FERT INTO A SEPARATE ROW/SEED	44
	2.7.1 FERTILIZER COULTERS	46
	2.7.2 FERTILIZER COULTER M	48
2.8	FRAME M, COMBI	50
2.9	SEED COULTER M	52
2.10	CENTRAL ADJUSTMENT OF THE COULTER PRESSURE M	53
2.11	FRAME D	54
	2.11.1 COULTER D	56
2.12	DRAWBAR S	58
2.13	DRAWBAR SMD	60
3.	WHEEL SET	62
3.1	FRAME OF THE WHEEL SET SMD	62
3.2	ROCKER SHAFT OF THE WHEEL SET SMD	64
3.3	CYLINDER AND MAINTENANCE SUPPORT OF THE WHEEL SET	66
3.4	FOLLOWING HARROW SMD	68

4	CONTROL UNIT	70
4.1	COMPONENTS	71
4.2	SURFACE AREA METER	72
5.	DRAW BOOM	73
5.1	DRAW BOOM S, FOR TOW BAR	73
5.2	DRAW BOOM S, FOR MAW	73
5.3	DRAW BOOM S, FOR PACKER	74
5.4	DRAW BOOM SMD, FOR TOW BAR	75
5.5	DRAW BOOM SMD, FOR PACKER	76
5.6	HOSES OF THE DRAW BOOMS	77
5.7	PACKER SMALL SMD	79
5.8	PACKER BIG SMD	81
6.	ACCESSORIES	82
6.1	FRONT LEVELLER SMD, 1-ROW	82
6.2	FRONT LEVELLER M, 1-ROW	84
6.3	FRONT LEVELLER, 2-ROW	86
	S-TINE MD, 2-ROW	86
6.4	DISC CULTIVATOR MD	88
	6.4.1 DISC CULTIVATOR	90
6.5	TRACKMARKER SMD	92
6.6	TRACKMARKER DISC	95
6.7	SMALL SEED DEVICE SMD, HOPPER	96
6.8	SMALL SEED DEVICE SMD, GEAR	98
6.9	SIEVES FOR SEED SMD	100
6.10	HALF CLOSE	101
6.1	ACCESSORIES FOR TRANSPORTING SMD	102

1.SÄILIÖ HOPPER

1.1 SÄILIÖ SMD, LANNOITE SAMAN RIVIIN HOPPER SMD, FERT INTO THE SAME ROW

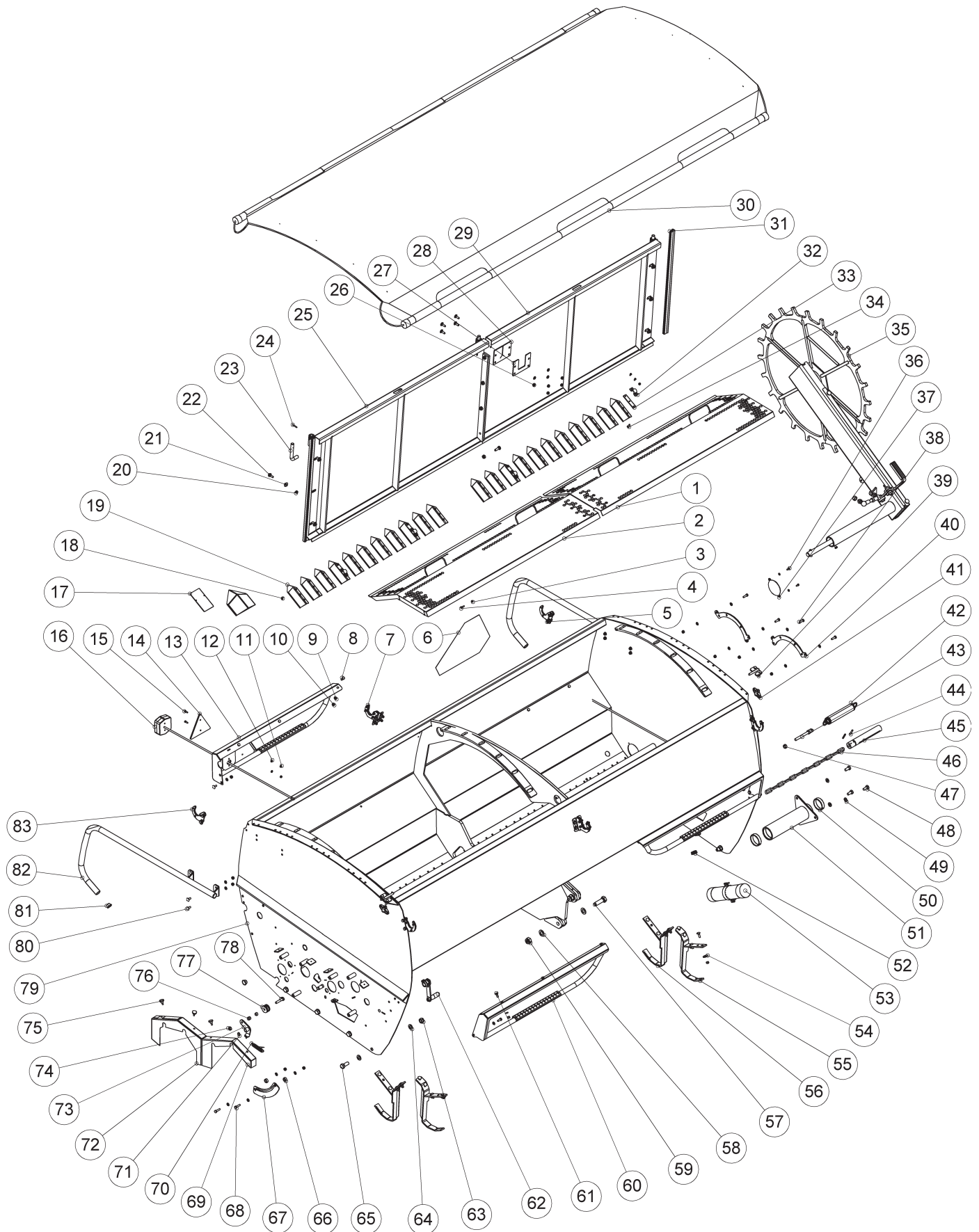

OSA PART CODE	KOODI	NIMITYS	DESCRIPTION	SM300		SM400		D300		D400	
				ECO	PLUS	ECO	PLUS	ECO	PLUS	ECO	PLUS
1	31864	LANN. SEULA VAS. 300 SAMARIVI	SIEVE, FERTILIZER LEFT	1	1			1	1		
	31921	SEULA LANN.PUOLI KP VAS.	SIEVE, FERTILIZER LEFT			1	1			1	1
2	31863	LANNOITEP. SEULA .KP OIK. SAMA	SIEVE, FERTILIZER RIGHT	1	1			1	1		
	31922	SEULA LANN.PUOLI KP OIK.	SIEVE, FERTILIZER RIGHT			1	1			1	1
3	A50451	6-MUTTERI II M6 DIN985 AISI	NUT	12	12	12	12	12	12	12	12
4	A0434	6-RUUVI M6X20 A2 DIN 933 AISI	SCREW	12	12	12	12	12	12	12	12
5	33077	KANNAKE2 KP	HOLDER	2	2	2	2	2	2	2	2
6	CF6000	TARRA HITANAANAJONEUVONKOLMIO	SMV STICKER	1	1	1	1	1	1	1	1
7	33075	LUKITSIN KP	LOCK	2	2	2	2	2	2	2	2
8	A080L1514	6-RUUVI M8X20 8.8 DIN 933 ZN	SCREW	8	8	8	8	8	8	8	8
9	B580H1624	ALUSLAATTA M 8 DIN125A ZN	WASHER	36	36	36	36	36	36	36	36
10	AG8113014	6-MUTTERI II M 8 DIN985-8 ZN	NUT	44	44	44	44	44	44	44	44
11	AG6113014	6-MUTTERI II M 6 DIN985-8 ZN	NUT	4	4	4	4	4	4	4	4
12	B560E1524	ALUSLAATTA M 6 DIN125A ZN	WASHER	2	2	2	2	2	2	2	2
13	31595	TAKAVALO PANEELI OIK. HITS	TAILLIGHT PANEL, RIGHT	1	1	1	1	1	1	1	1
	31592	TAKAVALO PANEELI VAS. HITS.	TAILLIGHT PANEL, LEFT	1	1	1	1	1	1	1	1
14	D50000385	HEIJASTIN KOLMIO 8301	REFLECTOR	2	2	2	2	2	2	2	2
15	A060G2024	URARUUVI M6X16 4.8 DIN 84 ZN	SCREW	4	4	4	4	4	4	4	4
16	CP4498R	VALOSARJA OIK.	LIGHTS RIGHT	1	1	1	1	1	1	1	1
	CP4498L	VALOSARJA VAS.	LIGHTS LEFT	1	1	1	1	1	1	1	1
17	33643	PEITELEVY D	PLATE D					12	12	16	16
18	A670G9824	X-LEVYR . 4.8X16 A2 DIN7981C POZ	SCREW	30	30	38	38	42	42	54	54
19	D17941	MAESTRON POHJAKARTIO 17941	BOTTOM CONE	22	22	30	30	10	10	14	14
	33623	SULKUKARTIO D	BOTTOM CONE D					12	12	16	16
20	A50710	6-MUTTERI II M8 A2 DIN985 AISI	NUT	10	10	10	10	10	10	10	10
21	B5A0V1525	KORILAATTA M8 DIN9021 A2	WASHER	6	6	6	6	6	6	6	6
22	A080F3014	LUKKOR. M8X25 4.6 RUOSTUMATON	LOCK SCREW	18	18	18	18	18	18	18	18
23	31819	LUKKOTAPPI VÄLISEINÄÄN	LOCK PIVOT	3	3	3	3	3	3	3	3
24	B85120001	JOUSISOKKA 5X32 DIN1481 ZNC	TUBULAR PIN	3	3	3	3	3	3	3	3
25	31460	VÄLISEINÄ HITS. OIK.	PARTITION WALL, RIGHT	1				1			
	31490	VÄLISEINÄ HITS., ISOSÄILIÖ	PARTITION WALL, RIGHT							1	
	33141	VÄLISEINÄ HITS. OIK. 400	PARTITION WALL, RIGHT			1					
	31916	VÄLISEINÄ HITS.	PARTITION WALL, RIGHT								1
26	B60649	ALUSLAATTA M 8 DIN125A A2 AISI	WASHER	4	4	4	4	4	4	4	4
27	31829	VASTALEVY	RESPONSE PLATE	1	1	1	1	1	1	1	1
28	31817	KUMITIVISTE	RUBBER JOINT	1	1	1	1	1	1	1	1
29	31816	VÄLISEINÄ HITS. VAS.	PARTITION WALL, LEFT	1				1			
	31835	VÄLISEINÄ HITS. VAS.	PARTITION WALL, LEFT							1	
	33139	VÄLISEINÄ HITS. VAS.	PARTITION WALL, LEFT								1
	31920	VÄLISEINÄ HITS. VAS.	PARTITION WALL, LEFT								1
30	33071	KANSIPEITE KP	LID	1		1		1			

OSA PART	KOODI CODE	NIMITYS	DESCRIPTION	SM300 ECO	SM300 PLUS	SM400 ECO	SM400 PLUS	D300 ECO	D300 PLUS	D400 ECO	D400 PLUS
31	33065	KANSIPEITE KP	LID	2	1	1	1		1		
	33142	KANSIPEITE KP	LID			1				1	
	33070	KANSIPEITE KP	LID				1				1
	31469	TIIVISTE	SEAL	2		2		2		2	
	31495	TIIVISTE	SEAL				2		2		
32	160828	LAAKERIN YLEMPI PUOLIKAS	BEARING, UPPER	4	4	4	4	4	4	4	4
33	20861	LAAKERIN ALEMPI PUOLIKAS	BEARING, LOWER	4	4	4	4	4	4	4	4
34	A060L1524	6-RUUVI M6X20 8.8 DIN 933 ZN	SCREW	4	4	4	4	4	4	4	4
35	31850	MAAPYÖRÄ KP	FRICITION WHEEL	1	1	1	1	1	1	1	1
36	A060C1024	6-RUUVI M6X12 8.8 DIN 933 ZN	SCREW	2	2	2	2	2	2	2	2
37	21204	LISÄSUOJA SEKOITINAKSELILLE	COVER PLATE	1	1	1	1	1	1	1	1
38	A080S1514	6-RUUVI M8X25 8.8 DIN933 ZN	SCREW	4	4	4	4	4	4	4	4
39	33074	KIINNITIN HITS.	LID HOLDER	2	2	2	2	2	2	2	2
40	31821	ASTEIKKOLEVY	SCALE PLATE	2	2	2	2	2	2	2	2
41	D30142	SIIPIVÄÄNNIN + TULPPA 80105	KNOB	2	2	2	2	2	2	2	2
42	D14711600	VETOJOUSI 5*40*250 4-7116S	TENSION SPRING	1	1	1	1	1	1	1	1
43	707510	KIRISTYSRUUVI KIRISTYPANT HITS	SCREW	1	1	1	1	1	1	1	1
44	B861A0001	JOUSISOKKA 6X40 DIN1481 ZNC	TUBULAR PIN	2	2	2	2	2	2	2	2
45	17252	LIUKUPUTKI	TUBE	1	1	1	1	1	1	1	1
46	17723	VETOKETTINKI MAAPYÖRÄÄN	CHAIN, FRICTION WHEEL	1	1	1	1	1	1	1	1
47	AGC111014	6-MUTTERI M12 DIN934-8 ZN	NUT	1	1	1	1	1	1	1	1
48	A0C0S1512	6-RUUVI M12X25 8.8 DIN933 ZN	SCREW	3	3	3	3	3	3	3	3
49	B5C0R2024	ALUSLAATTA M12 DIN125A ZN	WASHER	3	3	3	3	3	3	3	3
50	17400	LIUKUHOLKKI	BUSHING	2	2	2	2	2	2	2	2
51	17398	MAAPYÖRÄN KIINNIKE	HOLDER, FRICTION WHEEL	1	1	1	1	1	1	1	1
52	21248	TULPPA SFL32X0,8-2,0	PLUG	4	4	4	4	4	4	4	4
53	27014	OHJEKIRJAN SUOJAPUTKI KOOTTU	CASING TUBE FOR MANUAL	1	1	1	1	1	1	1	1
54	B580V1544	KORILAATTA M 8 DIN440R ZN	WASHER	16	16	16	16	16	16	16	16
55	31861	ASENTOLEVY HITS.	POSITION PLATE	2	2	2	2	2	2	2	2
56	17676	ASENTOLEVY HITS.	POSITION PLATE	2	2	2	2	2	2	2	2
57	A13700	6-RUUVI M20X65 8.8 DIN933 ZNC	SCREW	4	4	4	4	4	4	4	4
58	B5L173024	ALUSLAATTA M20 DIN125A ZN	WASHER	8	8	8	8	8	8	8	8
59	AGL113014	6-MUTTERI II M20 DIN985-8 ZN	NUT	4	4	4	4	4	4	4	4
60	31597	ETUPANEELI OIK.	FRONT PANEL, RIGHT	1	1	1	1	1	1	1	1
	31599	ETUPANEELI VAS.	FRONT PANEL, LEFT	1	1	1	1	1	1	1	1
61	A04355	6-RUUVI M8X20 A2-80 DIN 933 AI	SCREW	6	6	6	6	6	6	6	6
62	33485	KIERTOKOEVEIVI KP	CRANK	1	1	1	1	1	1	1	1
63	AGG113014	6-MUTTERI II M16 DIN985-8 ZN	NUT	8	8	8	8	8	8	8	8
64	B5G102524	ALUSLAATTA M16 DIN125A ZN	WASHER	16	16	16	16	16	16	16	16
65	A0G1A1514	6-RUUVI M16X40 8.8 DIN933 ZN	SCREW	8	8	8	8	8	8	8	8
66	13445	HOLKKI KETJUNKIRISTÄJÄÄN	SPACER	2	2	2	2	2	2	2	2
67	21114	ASTEIKKOKAARI LANNOITEP.	POSITION PLATE, FERTILIZER	1	1	1	1	1	1	1	1
68	A08101514	6-RUUVI M8X30 8.8 DIN933 ZNC	SCREW	2	2	2	2	2	2	2	2

OSA PART	KOODI CODE	NIMITYS	DESCRIPTION	SM300 ECO	SM300 PLUS	SM400 ECO	SM400 PLUS	D300 ECO	D300 PLUS	D400 ECO	D400 PLUS
69	31859	SUOJALEVY LANN.PUOLI	COVER PLATE, FERTILIZER	1	1	1	1	1	1	1	1
70	D14105	VETOJOUSI 2.25*18*90 SINK9208S	TENSION SPRING	1	1	1	1	1	1	1	1
71	BH0H11L16	SEGER-RENGAKS 16X1 471	CIRCLIP	1	1	1	1	1	1	1	1
72	31869	SUOJALEVY SIEM.PUOLI	COVER PLATE, SEED	1	1	1	1	1	1	1	1
73	19081	KETJUNKIRISTÄJÄ HITS	TIGHTEN FOR CHAIN	1	1	1	1	1	1	1	1
74	AGA111014	6-MUTTERI M10 DIN934-8 ZN	NUT	1	1	1	1	1	1	1	1
75	A01560	SORMIRUUVI M*6X10 /32799900	SCREW	6	6	6	6	6	6	6	6
76	D15186	PAINEHOLK SINK.KELTAP.4-15186	BUSHING	2	2	2	2	2	2	2	2
77	137224	RULLA KETJUNKIRISTÄJÄÄN	ROLL	1	1	1	1	1	1	1	1
78	A0A1L1014	6-RUUVI M10X50 8.8 DIN933 ZN	SCREW	1	1	1	1	1	1	1	1
79	31779	SÄILIÖ HITS. LYHYT VÄLI	HOPPER	1				1			
	31471	SÄILIÖ ISO, LYHYT SYÖTTÖVÄLI	HOPPER		1				1		
	33178	SÄILIÖ HITS. LYHYT VÄLI	HOPPER			1				1	
	31810	SÄILIÖ HITS. LYHYT VÄLI	HOPPER				1				1
80	A05150	LUKKORUUVI M8X20 A2 DIN 603	SCREW	10	10	10	10	10	10	10	10
81	010425	MUOVITULPPA MUSTA	PLUG	6	6	6	6	6	6	6	6
82	33284	KAIDE OIK.	HANDRAIL, RIGHT	1	1	1	1	1	1	1	1
	33283	KAIDE VAS.	HANDRAIL, LEFT	1	1	1	1	1	1	1	1
83	33076	KANNAKE1KP	HOLDER	2	2	2	2	2	2	2	2

1.2 KONEISTO SMD, LANNOITE SAMAN RIVIIN GEAR SMD, FERT INTO THE SAME ROW

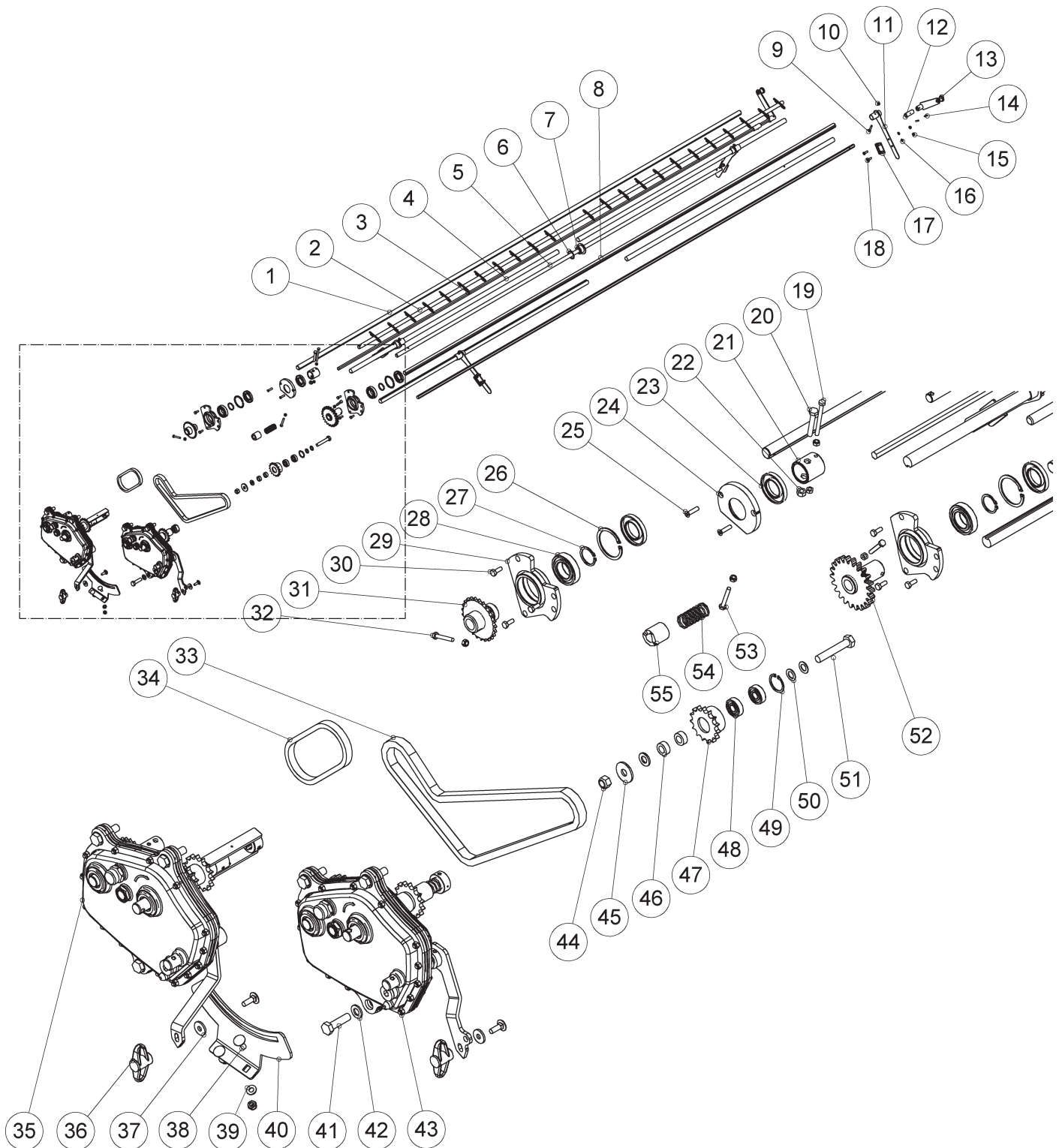

OSA PART	KOODI CODE	NIMITYS	DESCRIPTION	SM300		SM400		D300		D400	
				ECO	PLUS	ECO	PLUS	ECO	PLUS	ECO	PLUS
1	31867	SYÖTTÖAKSELI SIEM.PUOLI	FEED SHAFT, SEED	1	1			1	1		
	31937	SYÖTTÖAKSELI SIEM.PUOLI	FEED SHAFT, SEED			1	1			1	1
2	21206	SEKOITINAKSELI HITSATTU	MIXER SHAFT	1	1						
	21245	SEKOITINAKSELI HITSATTU	MIXER SHAFT			1	1				
	33644	SEKOITINAKSELI HITSATTU	MIXER SHAFT					1	1		
	33647	SEKOITINAKSELI HITSATTU	MIXER SHAFT							1	1
3	31865	PIKKULÄPÄN AKSELI	LITTLE FLAP SHAFT	2	2			2	2		
	31939	PIKKULÄPÄN AKSELI	LITTLE FLAP SHAFT			2	2			2	2
4	17563	POHJÄLÄPÄN AKSELI	BOTTOM FLAP SHAFT	4	4			4	4		
	18140	POHJÄLÄPÄN AKSELI 4000	BOTTOM FLAP SHAFT			4	4			4	4
5	31855	KARDAANIASELI	DRIVE SHAFT	1	1			1	1		
	33004	KARDAANIASELI	DRIVE SHAFT			1	1			1	1
6	BH1511L12	SEGER-RENG AKS 34X1.5 471	CIRCLIP	1	1	1	1	1	1	1	1
7	18459	TUKILAAKERI KARDANILLE	BEARING FOR DRIVE SHAFT	1	1	1	1	1	1	1	1
8	31866	SYÖTTÖAKSELI LANN.PUOLI	FEED SHAFT, FERTILIZER	1	1			1	1		
	31934	SYÖTTÖAKSELI LANN.PUOLI	FEED SHAFT, FERTILIZER			1	1			1	1
9	A06151514	6-RUUVI M6X35 8.8 DIN 933 ZN	SCREW	4	4	4	4	4	4	4	4
10	AG6113014	6-MUTTERI II M 6 DIN985-8 ZN	NUT	5	5	5	5	5	5	5	5
11	17671	VIPU HITS.	LEVER	4	4	4	4	4	4	4	4
12	33158	HOLKKI	BUSHING	2	2	2	2	2	2	2	2
13	31713	SÄÄTÖVIPU KOOTTU	LEVER	2	2	2	2	2	2	2	2
14	B840N0001	JOUSISOKKA 4X22 DIN1481 ZNC	TUBULAR PIN	4	4	4	4	4	4	4	4
15	A50452	6-MUTTERI M6 A2 DIN934 AISI	NUT	8	8	8	8	8	8	8	8
16	B560B1615	JOUSIALUSL. M6 DIN127B A2 AISI	SPRING WASHER	8	8	8	8	8	8	8	8
17	161505	LUKITSIN SÄÄTÖVIPUUN	LOCK FOR LEVER	4	4	4	4	4	4	4	4
18	A02100	URARUUVI M6X16 A2 DIN 7985 POZ	SCREW	8	8	8	8	8	8	8	8
19	A03655	6-RUUVI M6X70 8.8 DIN931 ZN	SCREW	1	1	1	1	1	1	1	1
20	A05101812	6-RUUVI M5X50 DIN 933	SCREW	1	1	1	1	1	1	1	1
21	21129	HOLKKI SEK.AKSELIIN	BUSHING	1	1	1	1	1	1	1	1
22	AG8113014	6-MUTTERI II M 8 DIN985-8 ZN	NUT	3	3	3	3	3	3	3	3
23	D49009	STEFA 30*55*7 CRW1R	SHAFT SEAL	1	1	1	1	1	1	1	1
24	19922	TIIVISTEPESA	HOUSING	1	1	1	1	1	1	1	1
25	A060L2025	URAR. M6X25 4.8 DIN 84 ZN	SCREW	2	2	2	2	2	2	2	2
26	BH1S1S0J1	SEGER-RENG REI 55X2 472	CIRCLIP	2	2	2	2	2	2	2	2
27	BH1011L11	SEGER-RENG AKS 30X1.5 471	CIRCLIP	2	2	2	2	2	2	2	2
28	CE60062RS	KUULALAAKERI 6006 2 RS	BEARING	2	2	2	2	2	2	2	2
29	17185	LAAKERIPESÄ VIISTETTY	BEARING HOUSING	2	2	2	2	2	2	2	2
30	A060G1024	6-RUUVI M6X16 8.8 DIN 933 ZN	SCREW	6	6	6	6	6	6	6	6
31	21130	KETJUP. HITS. Z25 3/8"	PINION	1	1	1	1	1	1	1	1
32	A061A1524	6-RUUVI M6X40 8.8 DIN 933 ZN	SCREW	2	2	2	2	2	2	2	2
33	31987	RULLAKETJU	CHAIN	1	1	1	1	1	1	1	1

OSA PART	KOODI CODE	NIMITYS	DESCRIPTION	SM300 ECO	SM300 PLUS	SM400 ECO	SM400 PLUS	D300 ECO	D300 PLUS	D400 ECO	D400 PLUS
34	21239	KETJU SYÖTTÖAKSELILLE	CHAIN FOR FEED SHAFT	1	1	1	1	1	1	1	1
35	31889	VAIHDELAATIKKO KOOTTU SP	GEARBOX, SEED	1	1	1	1	1	1	1	1
36	D30142	SIIPIVÄÄNNIN + TULPPA 80105	KNOB	2	2	2	2	2	2	2	2
37	19848	KUMIPRIKKA 9*25	WASHER	2	2	2	2	2	2	2	2
38	A080S3014	LUKKOR. M8X25 4.6 DIN 603 ZN	SCREW	4	4	4	4	4	4	4	4
39	B580H1624	ALUSLAATTA M 8 DIN125A ZN	WASHER	2	2	2	2	2	2	2	2
40	31347	KAARILEVY SIEMENUOLI	POSITION PLATE, SEED	1	1	1	1	1	1	1	1
41	A0C1F1024	6-RUUVI M12X45 8.8 DIN933 ZN	SCREW	6	6	6	6	6	6	6	6
42	B5C0R2024	ALUSLAATTA M12 DIN125A ZN	WASHER	7	7	7	7	7	7	7	7
43	31870	VAIHDELAATIKKO LANN.PUOLI KP	GEARBOX, FERTILIZER	1	1	1	1	1	1	1	1
44	AGC113014	6-MUTTERI II M12 DIN985-8 ZN	NUT	1	1	1	1	1	1	1	1
45	B5C0R2124	KORILAATTA M12 DIN9021.ZN	WASHER	1	1	1	1	1	1	1	1
46	13445	HOLKKI KETJUNKIRISTÄJÄÄN	SOCKET	2	2	2	2	2	2	2	2
47	137351	KETJUPYÖRÄ Z15 1/2"	PINION	1	1	1	1	1	1	1	1
48	CE62012RS	KUULALAAKERI 62012 RS	BEARING	2	2	2	2	2	2	2	2
49	BH1210L11	SEGER-RENG REI 32X1.2 472	CIRCLIP	1	1	1	1	1	1	1	1
50	120427	ALUSLAATTA	WASHER	2	2	2	2	2	2	2	2
51	A0C2A1514	6-RUUVI M12X70 8.8 DIN931 ZNC	SCREW	1	1	1	1	1	1	1	1
52	21136	HP. Z22 HITS.	PINION	1	1	1	1	1	1	1	1
53	A061F1014	6-RUUVI M6X45 8.8 DIN 931 ZN	SCREW	1	1	1	1	1	1	1	1
54	31975	PURISTUSJOUSI	PRESS SPRING	1	1	1	1	1	1	1	1
55	31976	KYTKINHOLKKI	CLUTCH SOCKET	1	1	1	1	1	1	1	1

1.3 SÄILIÖ SM, LANNOITE ERI RIVIIN HOPPER SM, FERT INTO A SEPARATE ROW

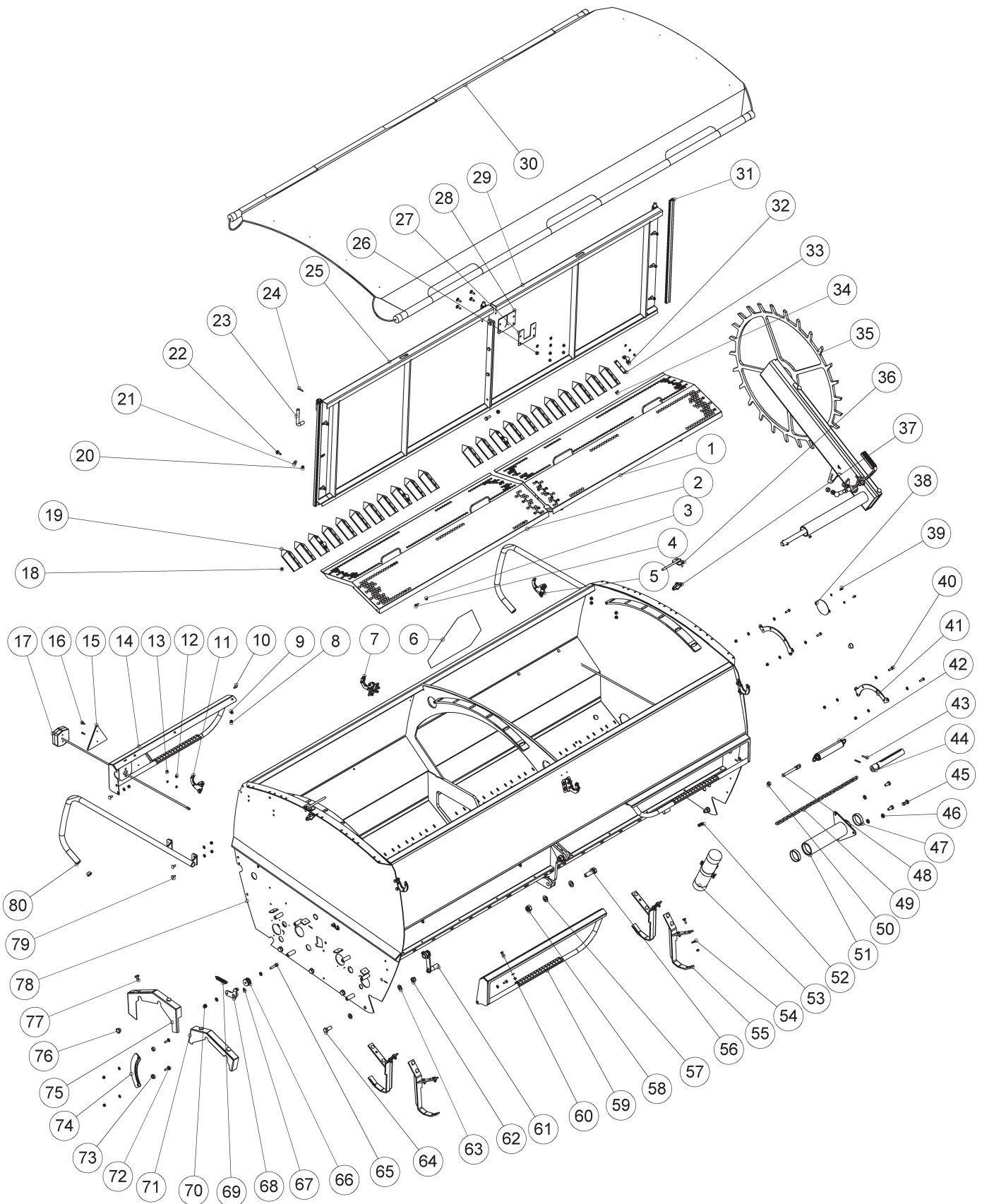

A GOOD WAY TO WORK HARD

OSA PART	KOODI CODE	NIMITYS	DESCRIPTION	SM300	SM300	SM400	SM400
				ECO	PLUS	ECO	PLUS
1	31423	LANN. SEULA VAS. ERI	SIEVE, FERTILIZER LEFT	1	1		
	33135	SEULA VAS. 400 KP	SIEVE, FERTILIZER LEFT			1	1
2	31421	LANN. SEULA OIK. ERI	SIEVE, FERTILIZER LEFT	1	1		
	33134	SEULA OIK. 400 KP	SIEVE, FERTILIZER RIGHT			1	1
3	A50451	6-MUTTERI II M6 DIN985 AISI	NUT	12	12	12	12
4	A0434	6-RUUVI M6X20 A2 DIN 933 AISI	SCREW	12	12	12	12
5	33077	KANNAKE2 KP	HOLDER	2	2	2	2
6	CF6000	TARRA HITANAJO.KOLMIO	SMV STICKER	1	1	1	1
7	33075	LUKITSIN KP	LOCK	2	2	2	2
8	AG8113014	6-MUTTERI II M 8 DIN985-8 ZN	NUT	44	44	44	44
9	B580H1624	ALUSLAATTA M 8 DIN125A ZN	WASHER	36	36	36	36
10	A080L1514	6-RUUVI M8X20 8.8 DIN 933 ZN	SCREW	8	8	8	8
11	33076	KANNAKE1 KP	HOLDER	2	2	2	2
12	AG6113014	6-MUTTERI II M 6 DIN985-8 ZN	NUT	8	8	8	8
13	B560E1524	ALUSLAATTA M 6 DIN125A ZN	WASHER	2	2	2	2
14	31595	TAKAVALO PANEELI OIK. HITS.	TAILLIGHT PANEL, RIGHT	1	1	1	1
	31592	TAKAVALO PANEELI VAS. HITS.	TAILLIGHT PANEL, LEFT	1	1	1	1
15	D50000385	HEIJASTIN KOLMIO 8301	REFLECTOR	2	2	2	2
16	A060G2024	URARUUVI M6X16 4.8 DIN 84 ZN	SCREW	4	4	4	4
17	CP4498R	VALOSARJA OIK.	LIGHTS ,RIGHT	1	1	1	1
	CP4498L	VALOSARJA VAS.	LIGHTS ,LEFT	1	1	1	1
18	A670G9824	X-LEVYR.4.8X16 A2 DIN7981C POZ MAESTRON POHJAKARTIO	SCREW BOTTOM CONE	30 22	30 22	38 30	38 30
19	D17941	17941					
20	A50710	6-MUTTERI II M8 A2 DIN985 AISI	NUT	10	10	10	10
21	B5A0V1525	KORILAATTA M8 DIN9021 A2	WASHER	6	6	6	6
22	A080F3014	LUKKOR. M8X25 4.6 RUOSTUM.	SCREW	18	18	18	18
23	31819	LUKKOTAPPI VÄLISEINÄÄN	LOCK PIVOT	3	3	3	3
24	B85120001	JOUSISOKKA 5X32 DIN1481 ZNC	TUBULAR PIN	3	3	3	3
25	31460	VÄLISEINÄ HITS. OIK.	PARTITION WALL, RIGHT	1			
	31490	VÄLISEINÄ HITS., ISOSÄILIÖ	PARTITION WALL, RIGHT		1		
	33141	VÄLISEINÄ HITS. OIK. 400	PARTITION WALL, RIGHT			1	
	31916	VÄLISEINÄ HITS.	PARTITION WALL, RIGHT				1
26	B60649	ALUSLAATTA M 8 DIN125A A2 AISII	WASHER	4	4	4	4
27	31829	VASTALEVY	RESPONSE PLATE	1	1	1	1
28	31817	KUMITIIIVISTE	RUBBER JOINT	1	1	1	1
29	31816	VÄLISEINÄ HITS. VAS.	PARTITION WALL, LEFT	1			
	31835	VÄLISEINÄ HITS. VAS.	PARTITION WALL, LEFT		1		
	33139	VÄLISEINÄ HITS. VAS.	PARTITION WALL, LEFT			1	
	31920	VÄLISEINÄ HITS. VAS	PARTITION WALL, LEFT				1
30	33071	KANSIPEITE KP	LID	1			
	33065	KANSIPEITE KP	LID		1		
	33142	KANSIPEITE KP	LID			1	
	33070	KANSIPEITE KP	LID				1
31	31469	TIIVISTE	SEAL	2		2	
	31495	TIIVISTE	SEAL		2		2
32	160828	LAAKERIN YLEMPI PUOLIKAS	BEARING, UPPER	4	4	4	4
33	20861	LAAKERIN ALEMPI PUOLIKAS	BEARING, LOWER	4	4	4	4
34	A060L1524	6-RUUVI M6X20 8.8 DIN 933 ZN	SCREW	4	4	4	4
35	31850	MAAPYÖRÄ KP	FRICTION WHEEL	1	1	1	1
36	33074	KIINNITIN HITS.	LID HOLDER	2	2	2	2
37	D30142	SIIPIVÄÄNNIN + TULPPA 80105	KNOB	4	4	4	4
38	21204	LISÄSUOJA SEKOITINAKS.	COVER PLATE	1	1	1	1
39	A060C1024	6-RUUVI M6X12 8.8 DIN 933 ZN	SCREW	2	2	2	2
40	A080S1514	6-RUUVI M8X25 8.8 DIN933 ZN	SCREW	4	4	4	4
41	31821	ASTEIKKOLEVY	POSITION PLATE	2	2	2	2
42	D14711600	VETOJOUSI 5*40*250 4-7116S	TENSION SPRING	1	1	1	1
43	B861A0001	JOUSISOKKA 6X40 DIN1481 ZNC	TUBULAR PIN	2	2	2	2

A GOOD WAY TO WORK HARD

OSA PART	KOODI CODE	NIMITYS	DESCRIPTION	SM300	SM300	SM400	SM400
				ECO	PLUS	ECO	PLUS
44	17252	LIUKUPUTKI	TUBE	1	1	1	1
45	A0C0S1512	6-RUUVI M12X25 8.8 DIN933 ZN	SCREW	3	3	3	3
46	B5C0R2024	ALUSLAATTA M12 DIN125A ZN	WASHER	9	9	9	9
47	17400	LIUKUHOLKKI	BUSHING	2	2	2	2
48	707510	KIRISTYSRUUVI KIR.PANT HITS	SCREW	1	1	1	1
49	17723	VETOKETTINKI MAAPYÖRÄÄN	CHAIN, FRICTION WHEEL	1	1	1	1
50	AGC111014	6-MUTTERI M12 DIN934-8 ZN	NUT	1	1	1	1
51	17398	MAAPYÖRÄN KIINNIKE	HOLDER, FRICTION WHEEL	1	1	1	1
52	21248	TULPPA SFL32X0,8-2,0	PLUG	4	4	4	4
53	27014	OHJEKIRJAN SUOJAPUTKI	CASING TUBE FOR MANUAL	1	1	1	1
54	B580V1544	KOOTTU					
54	B580V1544	KORILAATTA M 8 DIN440R ZN	WASHER	16	16	16	16
55	17676	ASENTOLEVY HITS.	POSITION PLATE	4	4	4	4
56	A13700	6-RUUVI M20X65 8.8 DIN933	SCREW	4	4	4	4
57	B5L173024	ZNC					
57	B5L173024	ALUSLAATTA M20 DIN125A ZN	WASHER	8	8	8	8
58	AGL113014	6-MUTTERI II M20 DIN985-8 ZN	NUT	4	4	4	4
59	31597	ETUPANEELI OIK.	FRONT PANEL, RIGHT	1	1	1	1
59	31599	PANEELI VAS.	FRONT PANEL, LEFT	1	1	1	1
60	A04355	6-RUUVI M8X20 A2-80 DIN 933	SCREW	6	6	6	6
61	33485	AI					
61	33485	KIERTOKOEVEIVI KP	CRANK	1	1	1	1
62	AGG113014	6-MUTTERI II M16 DIN985-8 ZN	NUT	8	8	8	8
63	B5G102524	ALUSLAATTA M16 DIN125A ZN	WASHER	16	16	16	16
64	A0G1A1514	6-RUUVI M16X40 8.8 DIN933 ZN	SCREW	8	8	8	8
65	A0A1A4524	6-KOLOR.M10X40 8.8 DIN912 ZN	SCREW	1	1	1	1
66	137224	RULLA KETJUNKIRISTÄJÄÄN	ROLL	1	1	1	1
67	BH0H11L16	SEGER-RENG AKS 16X1 471	CIRCLIP	1	1	1	1
68	19081	KETJUNKIRISTÄJÄ HITS	TIGHTEN FOR CHAIN	1	1	1	1
69	D14105	VETOJOUSI 2.25*18*90 SIN-K9208S	TENSION SPRING	1	1	1	1
70	AGA113014	6-MUTTERI II M10 DIN985-8 ZN	NUT	1	1	1	1
71	31912	SUOJALEVY LANN.PUOLI	COVER PLATE, FERTILIZER	1	1	1	1
72	A08103014	LUKKOR. M8X30 8.8 DIN 603 ZN	SCREW	2	2	2	2
73	13445	HOLKKI KETJUNKIRISTÄJÄÄN	SPACER	2	2	2	2
74	21114	ASTEIKKOKAARI LANNOITEP.	POSITION PLATE, FERTILIZER	1	1	1	1
75	31869	SUOJALEVY SIEM.PUOLI	COVER PLATE, SEED	1	1	1	1
76	010425	MUOVITULPPA MUSTA	PLUG	6	6	6	6
77	A01560	SORMIRUUVI M*6X10 /32799900	SCREW	4	4	4	4
78	31430	PIKKUSÄILIÖ HITS. ISOVÄLI	HOPPER	1			
78	31730	SÄILIÖ HITS. ISOVÄLI	HOPPER		1		
79	A05150	LUKKORUUVI M8X20 A2 DIN 603	SCREW	10	10	10	10
80	33284	KAIDE OIK.	HANDRAIL, RIGHT	1	1	1	1
80	33283	KAIDE VAS.	HANDRAIL, LEFT	1	1	1	1

1.4 KONEISTO SM, LANNOITE ERI RIVIIN GEAR SM, FERT INTO A SEPARATE ROW

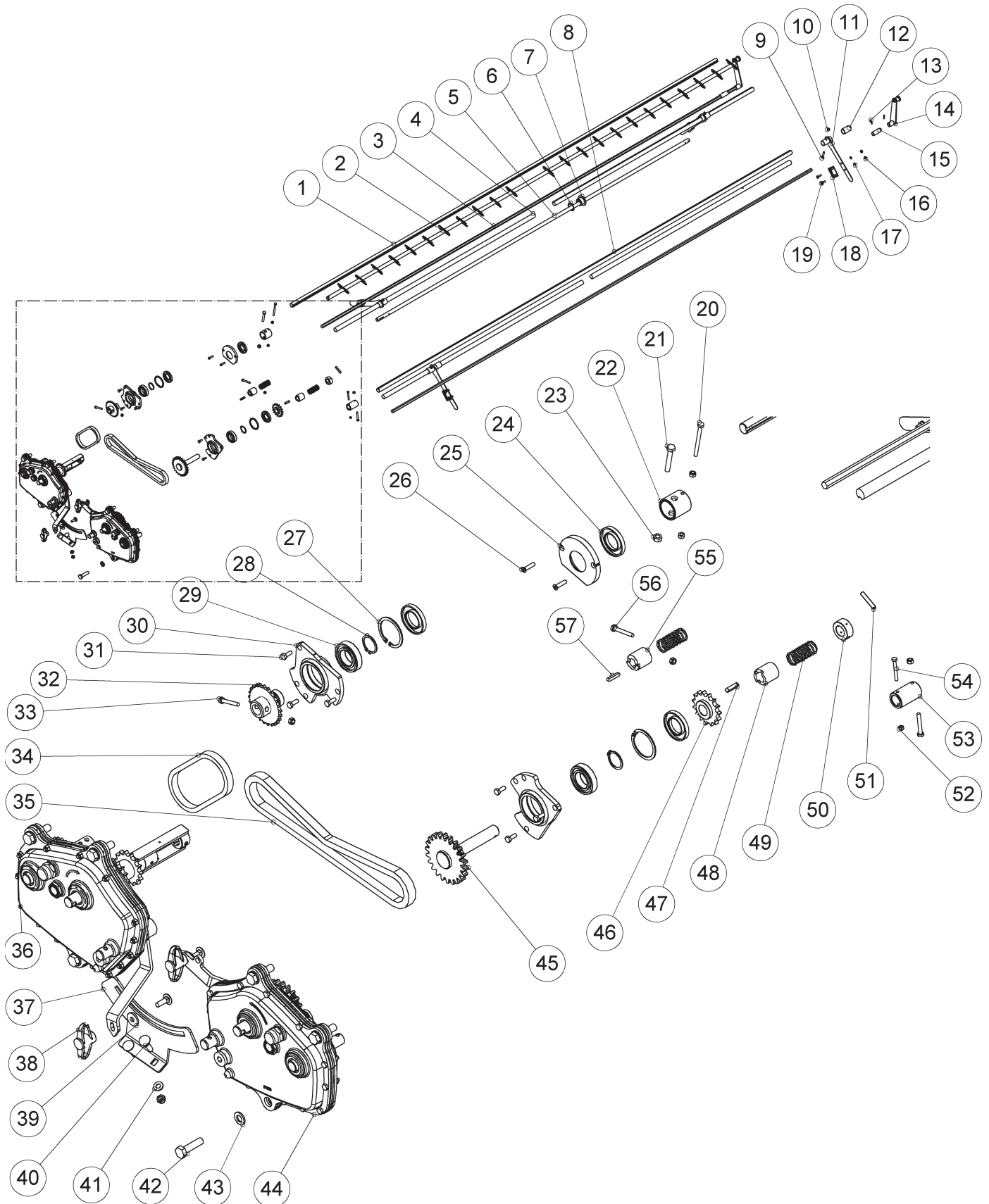

A GOOD WAY TO WORK HARD

OSA PART	KOODI CODE	NIMITYS	DESCRIPTION	SM300	SM300	SM400	SM400
				ECO	PLUS	ECO	PLUS
1	31867	SYÖTTÖAKSELI SIEM.PUOLI	FEED SHAFT, SEED	1	1		
	31937	SYÖTTÖAKSELI SIEM.PUOLI	FEED SHAFT, SEED			1	1
2	21206	SEKOITINAKSELI HITSATTU	MIXER SHAFT	1	1		
	21245	SEKOITINAKSELI HITSATTU	MIXER SHAFT			1	1
3	31865	PIKKULÄPÄN AKSELI	LITTLE FLAP SHAFT	2	2		
	31939	PIKKULÄPÄN AKSELI	LITTLE FLAP SHAFT			2	2
4	17563	POHJÄLÄPÄN AKSELI	BOTTOM FLAP SHAFT	4	4		
	18140	POHJÄLÄPÄN AKSELI 4000	BOTTOM FLAP SHAFT			4	4
5	31855	KARDAANIAKSELI	DRIVE SHAFT	1	1		
	33004	KARDAANIAKSELI	DRIVE SHAFT			1	1
6	BH1511L12	SEGER-RENG AKS 34X1.5 471	CIRCLIP	1	1	1	1
7	18459	TUKILAAKERI KARDANILLE	BEARING FOR DRIVE SHAFT	1	1	1	1
8	31866	SYÖTTÖAKSELI LANN.PUOLI	FEED SHAFT, FERTILIZER	1	1		
	31934	SYÖTTÖAKSELI LANN.PUOLI	FEED SHAFT, FERTILIZER			1	1
9	A06151514	6-RUUVI M6X35 8.8 DIN 933 ZN	SCREW	1	1	1	1
10	AG6113014	6-MUTTERI II M 6 DIN985-8 ZN	NUT	5	5	5	5
11	17671	VIPU HITS.	LEVER	4	4	4	4
12	33143	HOLKK	BUSHING	2	2	2	2
13	B840L0001	JOUSISOKKA 4X20 DIN1481 ZNC	TUBULAR PIN	2	2	2	2
14	31713	SÄÄTÖVIPU KOOTTU	LEVER	2	2	2	2
15	33158	HOLKKI	BUSHING	2	2	2	2
16	A50452	6-MUTTERI M6 A2 DIN934 AISI	NUT	8	8	8	8
		JOUSIALUSL. M6 DIN127B A2					
17	B560B1615	AISI	SPRING WASHER	8	8	8	8
18	161505	LUKITSIN SÄÄTÖVIPUUN	LOCK FOR LEVER	4	4	4	4
		URARUUVI M6X16 A2 DIN 7985					
19	A02100	POZ	SCREW	8	8	8	8
20	A03655	6-RUUVI M6X70 8.8 DIN931 ZN	SCREW	1	1	1	1
21	A05101812	6-RUUVI M5X50 DIN 933	SCREW	1	1	1	1
22	21129	HOLKKI SEK.AKSELIIN	BUSHING	1	1	1	1
23	AG8113014	6-MUTTERI II M 8 DIN985-8 ZN	NUT	3	3	3	3
24	D49009	STEFA 30*55*7 CRW1R	SHAFT SEAL	1	1	1	1
25	19922	TIIVISTEPESÄ	HOUSING	1	1	1	1
26	A060L2025	URAR. M6X25 4.8 DIN 84 ZN	SCREW	2	2	2	2
27	BH1S1S0J1	SEGER-RENG REI 55X2 472	CIRCLIP	2	2	2	2
28	BH1011L11	SEGER-RENG AKS 30X1.5 471	CIRCLIP	2	2	2	2
29	CE60062RS	KUULALAAKERI 6006 2 RS	BEARING	2	2	2	2
30	17185	LAAKERIPESÄ VIISTETTY	BEARING HOUSING	2	2	2	2
31	A060G1024	6-RUUVI M6X16 8.8 DIN 933 ZN	SCREW	6	6	6	6
32	21130	KETJUP. HITS. Z25 3/8"	PINION	1	1	1	1
33	A061A1524	6-RUUVI M6X40 8.8 DIN 933 ZN	SCREW	2	2	2	2
34	21239	KETJU SYÖTTÖAKSELILLE	CHAIN FOR FEED SHAFT	1	1	1	1
35	33006	RULLAKETJU	CHAIN	1	1	1	1
36	31889	VAIHDELAATIKKO KOOTTU SP	GEARBOX	1	1	1	1
37	31347	KAARILEVY SIEMENPUOLI	POSITION PLATE	1	1	1	1
38	D30142	SIIPIVÄÄNNIN + TULPPA 80105	KNOB	2	2	2	2
39	19848	KUMIPRIKKA 9*25	WASHER	2	2	2	2
40	A08153014	LUKKOR. M8X35 4.6 DIN 603 ZN	SCREW	2	2	2	2
41	B580H1624	ALUSLAATTA M 8 DIN125A ZN	WASHER	2	2	2	2
42	A0C1F1024	6-RUUVI M12X45 8.8 DIN933 ZN	SCREW	6	6	6	6
43	B5C0R2024	ALUSLAATTA M12 DIN125A ZN	WASHER	6	6	6	6
44	31394	VAIHDELAATIKKO LANN. KP	GEARBOX	1	1	1	1
45	31907	HP Z22 HITS.	PINION	1	1	1	1
46	31909	KETJUP.HITS.	PINION	1	1	1	1
47	31878	KIILA 6X6-28	COTTER	1	1	1	1
48	31877	KYTKINHOLKKI URALLINEN	CLUTCH SOCKET	1	1	1	1
49	31975	PURISTUSJOUSI	PRESS SPRING	2	2	2	2
50	33147	HOLKKI	BUSHING	1	1	1	1
51	B86160001	JOUSISOKKA 6X36 DIN1481 ZNC	TUBULAR PIN	1	1	1	1
52	AG5113014	6-MUTTERI II M 5 DIN985-8 ZN	NUT	1	1	1	1
53	31911	HOLKKI	BUSHING	1	1	1	1
54	A01270	6-RUUVI M5X40 8.8 DIN 933	SCREW	1	1	1	1
		ZNC					
55	31976	KYTKINHOLKKI	CLUTCH SOCKET	1	1	1	1

OSA PART	KOODI CODE	NIMITYS	DESCRIPTION	SM300	SM300	SM400	SM400
				ECO	PLUS	ECO	PLUS
56	A061F1014	6-RUUVI M6X45 8.8 DIN 931 ZN	SCREW	1	1	1	1
57	33005	KIILA 5X5	COTTER	1	1	1	1

1.5 SÄILIÖ SMD, SEED
HOPPER SMD, SEED

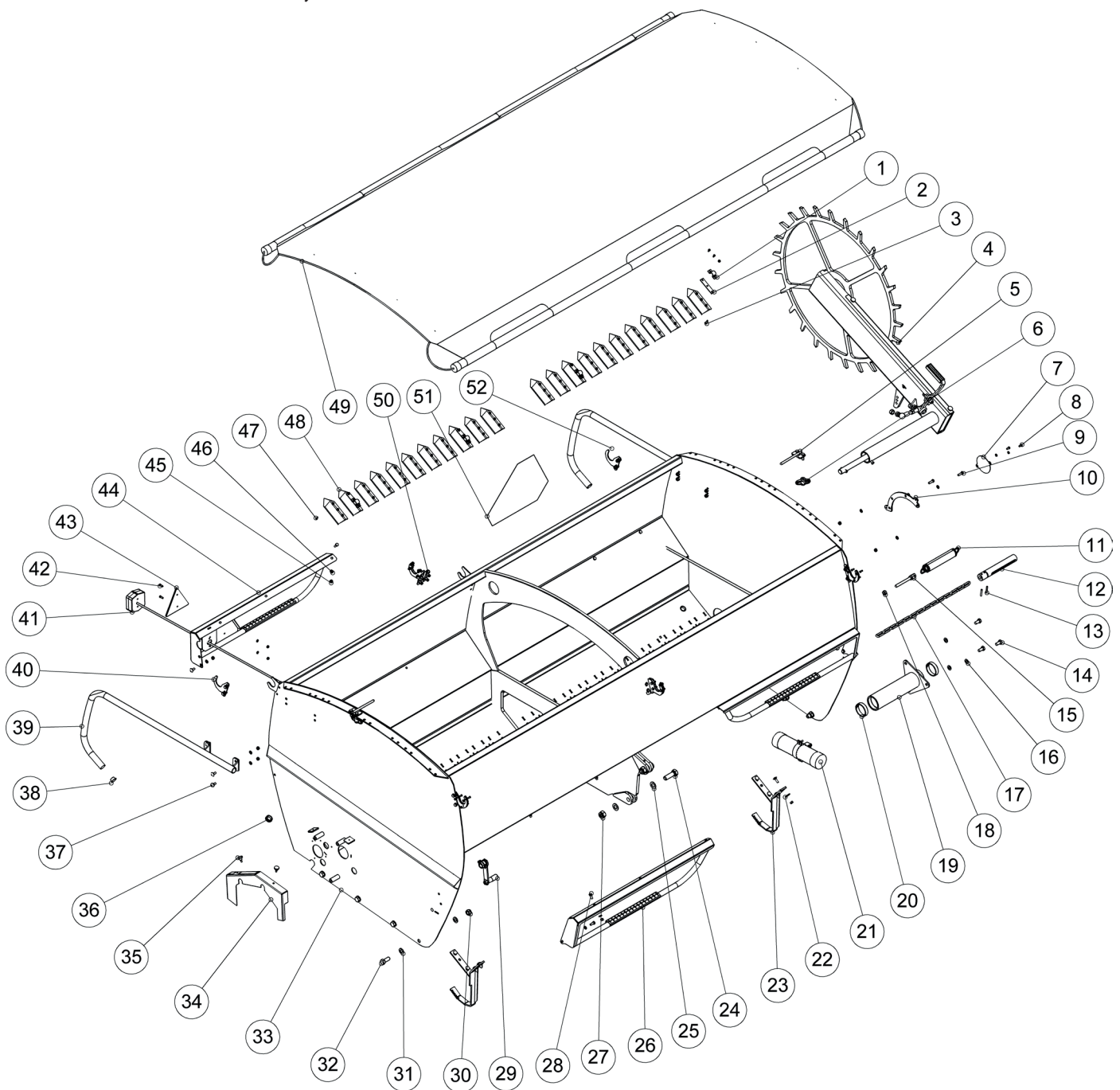

A GOOD WAY TO WORK HARD

OSA PART	KOODI CODE	NIMITYS	DESCRIPTION	SMD300	SMD400
				ECO	ECO
1	160828	LAAKERIN YLEMPI PUOLIKAS	BEARING, UPPER	4	4
2	20861	LAAKERIN ALEMPI PUOLIKAS	BEARING, LOWER	4	4
3	A060L1524	6-RUUVI M6X20 8.8 DIN 933 ZN	SCREW	4	4
4	31850	MAAPYÖRÄ KP	FRICTION WHEEL	1	1
5	33074	KIINNITIN HITS.	HOLDER	2	2
6	D30142	SIIPIVÄÄNNIN + TULPPA 80105	KNOB	3	3
7	21204	LISÄSUOJA SEKOITINAKSELILLE	COVER PLATE	1	1
8	A060C1024	6-RUUVI M6X12 8.8 DIN 933 ZN	SCREW	2	2
9	A080S1514	6-RUUVI M8X25 8.8 DIN933 ZN	SCREW	2	2
10	31821	ASTEIKKOLEVY	POSITION PLATE	1	1
11	D14711600	VETOJOUSI 5*40*250 4-7116S	TENSION SPRING	1	1
12	17252	LIUKUPUTKI	TUBE	1	1
13	B861A0001	JOUSISOKKA 6X40 DIN1481 ZNC	TUBULAR PIN	2	2
14	A0C0S1512	6-RUUVI M12X25 8.8 DIN933 ZN	SCREW	3	3
15	707510	KIRISTYSRUUVI KIRISTYPANT HITS	SCREW	1	1
16	B5C0R2024	ALUSLAATTA M12 DIN125A ZN	WASHER	6	6
17	17723	VETOKETTINKI MAAPYÖRÄÄN	CHAIN, FRICTION WHEEL	1	1
18	AGC111014	6-MUTTERI M12 DIN934-8 ZN	NUT	1	1
19	17398	MAAPYÖRÄN KIINNIKE	HOLDER, FRICTION WHEEL	1	1
20	17400	LIUKUHOLKKI	BUSHING	2	2
21	27014	OHJEKIRJAN SUOJAPUTKI KOOTTU	CASING TUBE FOR MANUAL	1	1
22	B580V1544	KORILAATTA M 8 DIN440R ZN	WASHER	8	8
23	17676	ASENTOLEVY HITS.	POSITION PLATE	2	2
24	A13700	6-RUUVI M20X65 8.8 DIN933 ZNC	SCREW	4	4
25	B5L173024	ALUSLAATTA M20 DIN125A ZN	WASHER	8	8
26	31597	ETUPANEELI OIK.	FRONT PANEL, RIGHT	1	1
	31599	ETUPANEELI VAS.	FRONT PANEL, LEFT	1	1
27	AGL113014	6-MUTTERI II M20 DIN985-8 ZN	NUT	4	4
28	A080L1514	6-RUUVI M8X20 8.8 DIN 933 ZN	SCREW	14	14
29	33485	KIERTOKOEVEIVI KP	CRANK	1	1
30	AGG113014	6-MUTTERI II M16 DIN985-8 ZN	NUT	8	8
31	B5G102524	ALUSLAATTA M16 DIN125A ZN	WASHER	16	16
32	A0G1A1514	6-RUUVI M16X40 8.8 DIN933 ZN	SCREW	8	8
33	31760	SÄILIÖ HITS. 300 SEED	HOPPER	1	
	33161	SÄILIÖ HITS. 400 ECO SEED	HOPPER		1
34	31869	SUOJALEVY SIEM.PUOLI	COVER PLATE	1	1
35	A01560	SORMIRUUVI M*6X10 /32799900	SCREW	2	2
36	21248	TULPPA SFL32X0,8-2,0	PLUG	2	2
37	A05150	LUKKORUUVI M8X20 A2 DIN 603	SCREW	10	10
38	010425	MUOVITULPPA MUSTA	PLUG	4	4
39	33284	KAIDE OIK.	HANDRAIL, RIGHT	1	1
	33283	KAIDE VAS.	HANDRAIL, LEFT	1	1
40	33076	KANNAKE1 KP	HOLDER	2	2
41	CP4498R	VALOSARJA OIK.	LIGHTS, RIHGT	1	1
	CP4498L	VALOSARJA VAS.	LIGHTS, LEFT	1	1
42	A060G2024	URARUUVI M6X16 4.8 DIN 84 ZN	SCREW	4	4
43	D50000385	HEIJASTIN KOLMIO 8301	REFLECTOR	2	2
44	31595	TAKAVALO PANEELI OIK. HITS.	TAILLIGHT PANEL, RIGHT	1	1
	31592	TAKAVALO PANEELI VAS. HITS.	TAILLIGHT PANEL, LEFT	1	1
45	AG8113014	6-MUTTERI II M 8 DIN985-8 ZN	NUT	34	34
46	B580H1624	ALUSLAATTA M 8 DIN125A ZN	WASHER	46	46
47	A670G9824	X-LEVYR.4.8X16 A2 DIN7981C POZ	SCREW	30	38
48	D17941	MAESTRON POHJAKARTIO 17941	BOTTOM CONE	22	30
49	33071	KANSIPEITE KP	LID	1	
	33142	KANSIPEITE KP	LID		1
50	33075	LUKITSIN KP	LOCK	2	2
51	CF6000	TARRA HITAAAJON.KOLMIO	SMV STICKER	1	1
52	33077	KANNAKE2 KP	HOLDER	2	2

1.6 KONEISTO SMD, SEED GEAR SMD, SEED

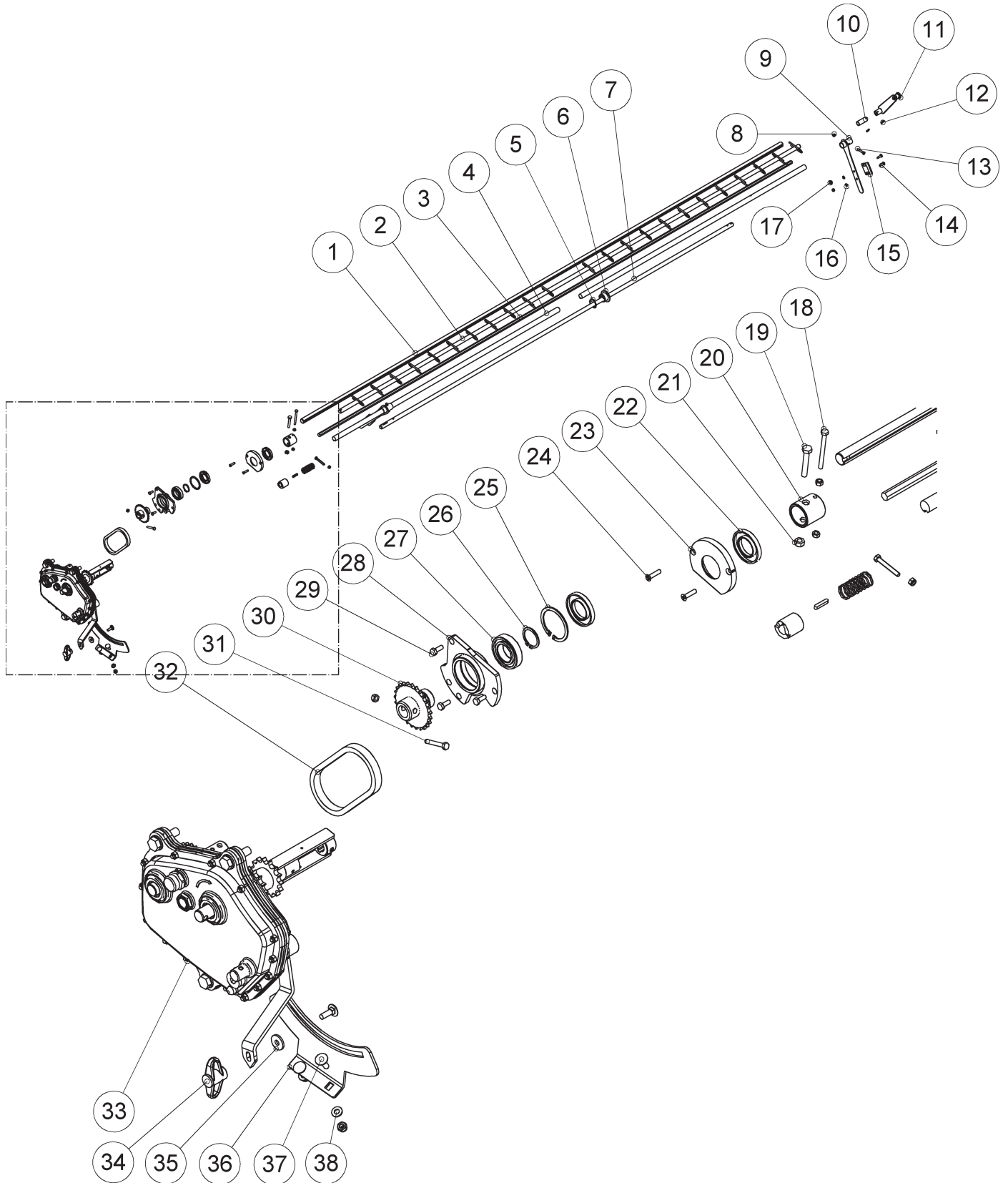

A GOOD WAY TO WORK HARD

OSA PART	KOODI CODE	NIMITYS	DESCRIPTION	SMD300 ECO	SMD400 ECO
1	31867	SYÖTTÖAKSELI SIEM.PUOLI	FEED SHAFT, SEED	1	
	31937	SYÖTTÖAKSELI SIEM.PUOLI	FEED SHAFT, SEED		1
2	21206	SEKOITINAKSELI HITSATTU	MIXER SHAFT	1	
	21245	SEKOITINAKSELI HITSATTU	MIXER SHAFT		1
3	31865	PIKKULÄPÄN AKSELI	LITTLE FLAP SHAFT	1	
	31939	PIKKULÄPÄN AKSELI	LITTLE FLAP SHAFT		1
4	17563	POHJÄLÄPÄN AKSELI	BOTTOM FLAP SHAFT	2	
	18140	POHJÄLÄPÄN AKSELI 4000	BOTTOM FLAP SHAFT		2
5	BH1511L12	SEGER-RENG AKS 34X1.5 471	CIRCLIP	1	1
6	18459	TUKILAAKERI KARDANILLE	BEARING FOR DRIVE SHAFT	1	1
7	31855	KARDAANIASELI	DRIVE SHAFT	1	
	33004	KARDAANIASELI	DRIVE SHAFT		1
8	AG6113014	6-MUTTERI II M 6 DIN985-8 ZN	NUT	4	4
9	17671	VIPU HITS.	LEVER	2	2
10	33158	HOLKKI	BUSHING	1	1
11	31713	SÄÄTÖVIPU KOOTTU	LEVER	1	1
12	B840N0001	JOUSISOKKA 4X22 DIN1481 ZNC	TUBULAR PIN	1	1
13	A06151514	6-RUUVI M6X35 8.8 DIN 933 ZN	SCREW	2	2
14	A02100	URARUUVI M6X16 A2 DIN 7985 POZ	SCREW	4	4
15	161505	LUKITSIN SÄÄTÖVIPUUN	LOCK	2	2
16	B560B1615	JOUSIALUSL. M6 DIN127B A2 AISI	SPRING WASHER	4	4
17	A50452	6-MUTTERI M6 A2 DIN934 AISI	NUT	4	4
18	A03655	6-RUUVI M6X70 8.8 DIN931 ZN	SCREW	1	1
19	A05101812	6-RUUVI M5X50 DIN 933	SCREW	1	1
20	21129	HOLKKI SEK.AKSELIIN	BUSHING	1	1
21	AG8113014	6-MUTTERI II M 8 DIN985-8 ZN	NUT	3	3
22	D49009	STEFA 30*55*7 CRW1R	SHAFT SEAL	1	1
23	19922	TIIVISTEPESÄ	HOUSING	1	1
24	A060L2025	URAR. M6X25 4.8 DIN 84 ZN	SCREW	2	2
25	BH1S1S0J1	SEGER-RENG REI 55X2 472	CIRCLIP	1	1
26	BH1011L11	SEGER-RENG AKS 30X1.5 471	CIRCLIP	1	1
27	CE60062RS	KUULALAAKERI 6006 2 RS	BEARING	1	1
28	17185	LAAKERIPESÄ VIISTETTY	HOUSING	1	1
29	A060G1024	6-RUUVI M6X16 8.8 DIN 933 ZN	SCREW	3	3
30	21130	KETJUP. HITS. Z25 3/8"	PINION	1	1
31	A061A1524	6-RUUVI M6X40 8.8 DIN 933 ZN	SCREW	1	1
32	21239	KETJU SYÖTTÖAKSELILLE	CHAIN FOR FEED SHAFT	1	1
33	31889	VAIHDELAATIKKO KOOTTU SP	GEARBOX	1	1
34	D30142	SIIPIVÄÄNNIN + TULPPA 80105	KNOB	1	1
35	19848	KUMIPRIKKA 9*25	WASHER	1	1
36	31347	KAARILEVY SIEMENPUOLI	POSITION PLATE	1	1
37	A080S3014	LUKKOR. M8X25 4.6 DIN 603 ZN	SCREW	3	3
38	B580H1624	ALUSLAATTA M 8 DIN125A ZN	WASHER	2	2

1.7 VAIHDELAATIKKO, SIEMEN GEARBOX, SEED

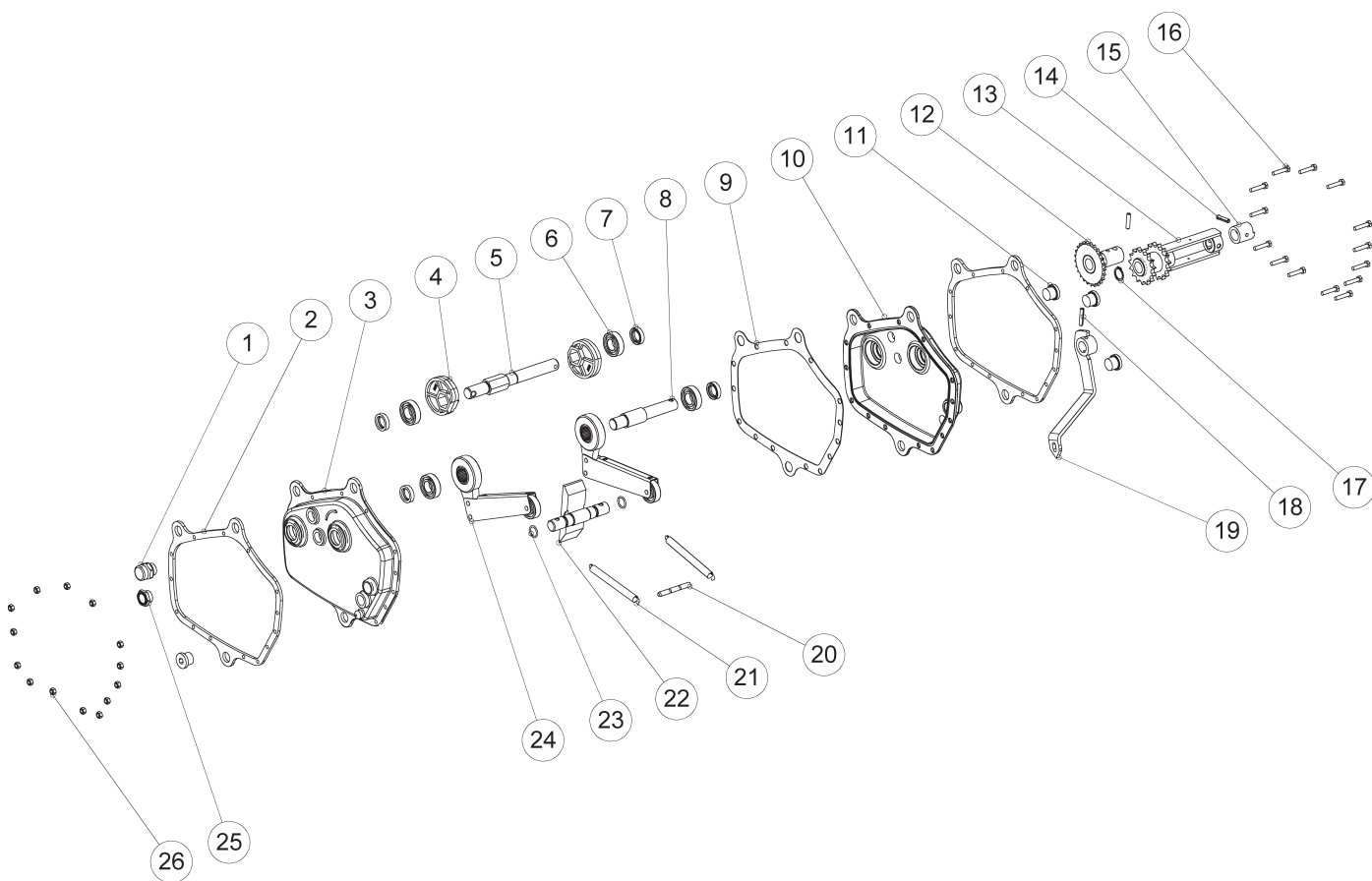

OSA PART	KOODI CODE	NIMITYS	DESCRIPTION	KPL/PCS
1	D123000	HUOHOTINKORKKI 1/2 TSF-3	BREATHER PLUG	1
2	21212	KIRISTYSVANNE	TIGHTENING RIM	2
3	18648	VAIHDELAATIKON ETUKANSI	FRONT COVER	1
4	18627	RYTMIPYÖRÄ	RHYTHM WHEEL	2
5	31899	LIMPPUAKSELI	SHAFT	1
6	CE60040	KUULALAAKERI 6004	BEARING	4
7	CNA20307	STEFA DIN 3760 B20*30*7	SHAFT SEAL	4
8	18614	TOISIOAKSELI	SECONDARY SHAFT	1
9	21225	KANNENTIIVISTE	GASKET	1
10	31393	VAIHDELAATIKON KANSI	REAR COVER	1
11	133668P	KUUSIOKOLOTULPPA 02608 R1/2	PLUG	4
12	21131	KETJUP. HITS. Z25 3/8"	PINION	1
13	31903	KYTKINRUNKO HITS. JOUISOKKA 6X28 DIN1481	CLUTCH FRAME	1
14	B860V0001	ZNC	TUBULAR PIN	2
15	31904	KYTKINNAPA REIJÄLLINEN 6-RUUVI. M6X30 8.8 DIN 933	CLUTCH HUB	1
16	A020808	MP	SCREW	14
17	BH012014	SEGER-RENG AKS 20X1.2 471	CIRCLIP	1
18	B86120001	ZNC	TUBULAR PIN	1
19	21139	SAATÖVIPU HITS. SIEMENP.	LEVER	1
20	18629	TAPPI JOUSIEN ALAPÄÄ	PIVOT	1
21	18626	JOUSI	SPRING	2
22	18645	SÄÄTÖAKSELI HITS.	CONTROL SHAFT	1
23	D163240	O-RENGAS 16.3*2.40	O-RING	2

1.8 VAIHDELAATIKKO, LANNOITE GEARBOX, FERTILIZER

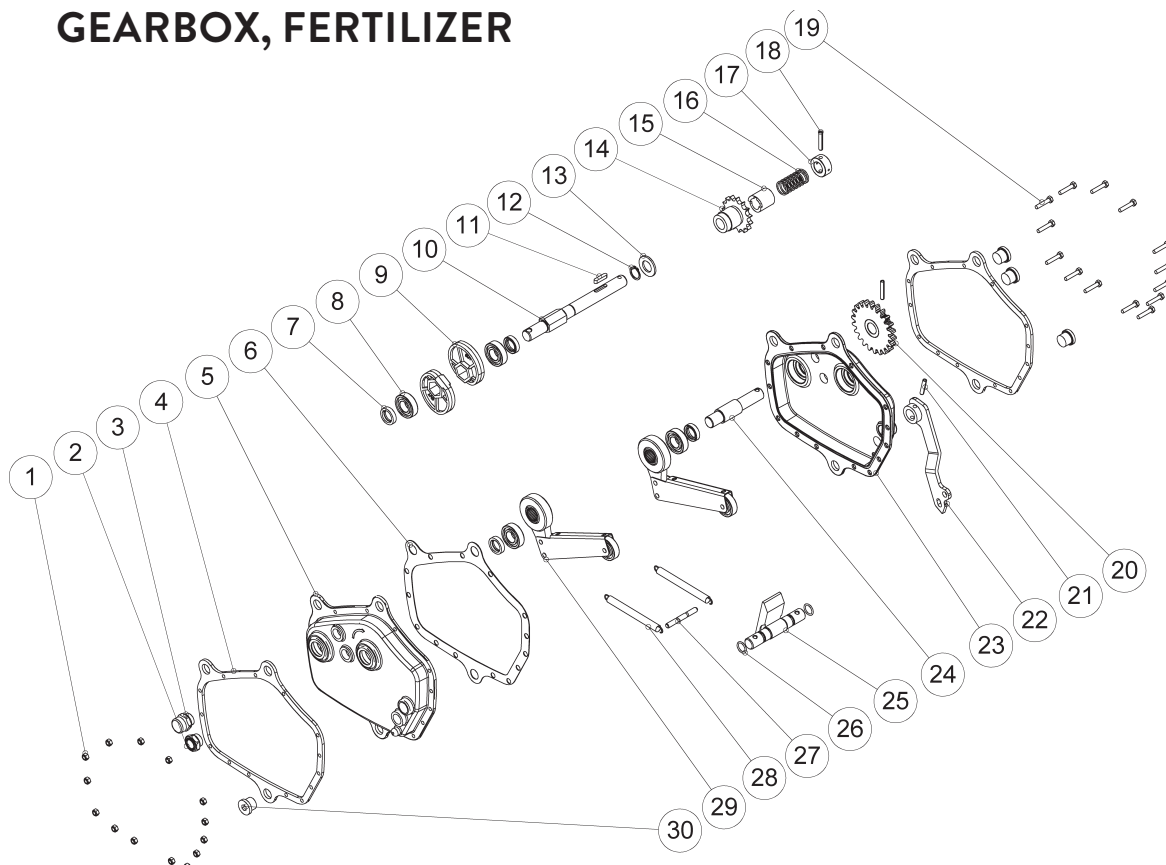

OSA PART	KOODI CODE	NIMITYS	DESCRIPTION	KPL/PCS
1	AG6113014	6-MUTTERI II M 6 DIN985-8 ZN	NUT	14
2	DG120TLA	ÖLJYSILMÄ 1/2 TLA-3	OILCHECK EYE	1
3	D123000	HUOHOTINKORKKI 1/2 TSF-3	BREATHER PLUG	1
4	21212	KIRISTYSVANNE	TIGHTENING RIM	2
5	18648	VAIHDELAATIKON ETUKANSI	FRONT COVER	1
6	21225	KANNENTIIVISTE	GASKET	1
7	CNA20307	STEFA DIN 3760 B20*30*7	SHAFT SEAL	4
8	CE60040	KUULALAAKERI 6004	BEARING	4
9	18627	RYTMIPYÖRÄ	RHYTHM WHEEL	2
10	31871	LIMPPUAKSELI	SHAFT	1
11	31878	KIILA 6X6-28	COTTER	1
12	BH012014	SEGER-RENG AKS 20X1.2 471	CIRCLIP	1
13	B5L173024	ALUSLAATTA M20 DIN125A ZN	WASHER	1
14	31876	KYTKINHOLKKI HITS.	CLUTCH SOCKET	1
15	31877	KYTKINHOLKKI URALLINEN	CLUTCH SOCKET	1
16	31975	PURISTUSJOUSI	PRESS SPRING	1
17	33147	HOLKKI	BUSHING	1
18	B86160001	JOUSISOKKA 6X36 DIN1481 ZNC	TUBULAR PIN	2
19	A06101014	6-RUUVI M6X30 8.8 DIN 933 ZN	SCREW	14
20	31874	HP. HITS. Z=22	PINION	1
21	B86120001	JOUSISOKKA 6X32 DIN1481 ZNC	TUBULAR PIN	1
22	31858	SÄÄTÖVIPU HITS. LP.	LEVER	1
23	31393	VAIHDELAATIKON KANSI	REAR COVER	1
24	31872	TOISIOAKSELI	SECONDARY SHAFT	1
25	18645	SÄÄTÖAKSELI HITS.	CONTROL SHAFT	1
26	D163240	O-RENGAS 16.3*2.40	O-RING	2
27	18629	TAPPI JOUSIEN ALAPÄÄ	PIVOT	1
28	18626	JOUSI	SPRING	2
29	18628	VIPU KP	LEVER	2
30	D43201	KUUSIOKOLOLOTULPPA E336 1/2	PLUG	4

1.9 MAAPYÖRÄ FRICITION WHEEL

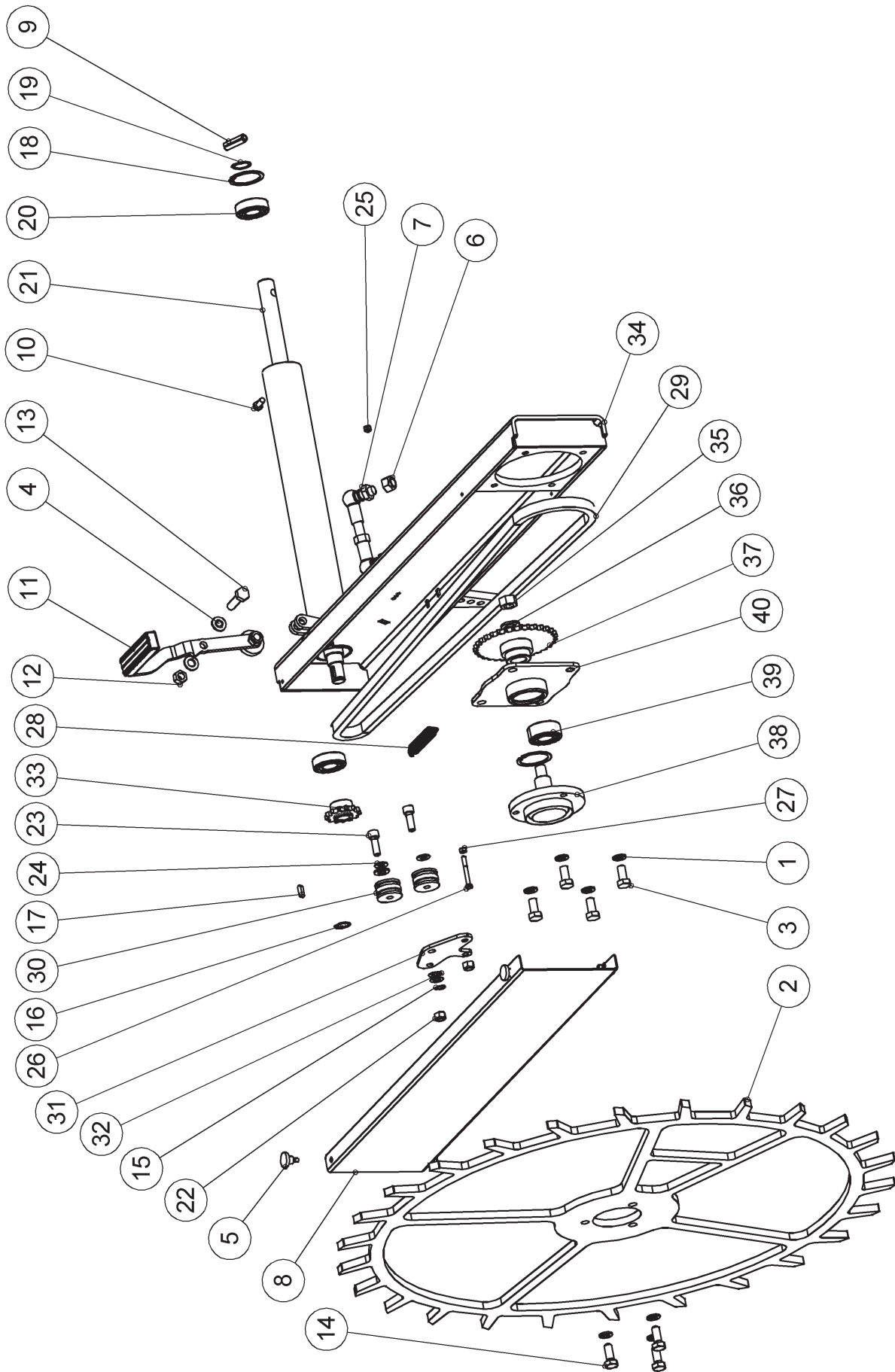

OSA PART	KOODI CODE	NIMITYS	DESCRIPTION	KPL/PCS
1	B5C0M2514	JOUSIALUS.M12 Din127B Zn	WASHER	7
2	22724	MAAPYÖRÄ HARMAA M14-	LAND WHEEL	1
3	A0C0S1512	6-RUUVI M12X25 8.8 Din933 Zn	SCREW	4
4	B5C0R2024	ALUSLAATTA M12 Din125A Zn	WASHER	3
5	A01560	SORMIRUUVI M*6X10 /32799900	SCREW	4
6	AGE113014	6-MUTTERI II M14 Din 985 Zn	NUT	2
7	33008	VIPU KP	LEVER	1
8	22722	SUOJAPELTI	COVER PLATE	1
9	B8C140001	JOUSISOKKA 12X40 Din1481 Znc	TUBULAR PIN	1
10	A080L1514	6-RUUVI M8X20 8.8 Din 933 Zn	SCREW	1
11	31853	VIPU KAHVALLA KP	LEVER	1
12	AGC113014	6-MUTTERI II M12 Din985-8 Zn	NUT	1
13	A0C1F1014	6-RUUVI M12X45 8.8 Din931Znc	SCREW	1
14	A0C101512	6-RUUVI M12X30 8.8 Din933Znc	SCREW	3
15	BH0C10011	SEGER. RENG. AKS. 12X1 471	CIRCLIP	1
16	BH0L12014	SEGER. RENG. AKS. 20X1.2 471	CIRCLIP	1
17	17577	KIILA 6*6*20	COTTER	1
18	BH1N20021	SEGER RENG REIK 52X2 472	CIRCLIP	2
19	BH0S10S14	SEGER RENG AKS 25X1.2 471	CIRCLIP	1
20	CE62052RS	KUULALAAKERI 6205 2 Rs	BEARING	2
21	31854	AKSELI MAAPYÖRÄN YLÄP.	SHAFT	1
22	AGA113014	6-MUTTERI II M10 Din985-8 Zn	NUT	2
23	A0A104524	6-KOLOR. M10X30 8.8 Din912 Zn	SCREW	2
24	B5A0MB024	ALUSLAATTA M10 Din125A Zn	WASHER	2
25	AG6113014	6-MUTTERI II M 6 Din985-8 Zn	NUT	1
26	A061L1011	6-RUUVI M6X50 8.8 Din 931 Zn	SCREW	1
27	AG6111014	6-MUTTERI M 6 Din934-8 Zn	NUT	1
28	D14105	VETOJOUSI 2.25*18*90 Sink9208S	SPRING	1
29	31220	RULLAK.1/2*153 LENKKIÄ	CHAIN	1
30	137224	RULLA KETJUNKIRISTÄJÄÄN	ROLL	2
31	35582	KIRISTYSKULMIO	TIGHTENING TRIANGLE	1
32	120427	ALUSLAATTA	WASHER	2
33	31852	KETJUP. HITS. Z=13	PINION	1
34	31842	MAAPYÖRÄN KÄSIVARSI HITS.	ARM	1
35	AGG111084	6-MUTTERI M16 VASENKÄTINEN	NUT	1
36	B5G102524	ALUSLAATTA M16 Din125A Zn	WASHER	1
37	36187	KETJUP. HITS. MAAPYÖRÄÄN	PINION	1
38	17295	MAAPYÖRÄN AKSELI HITS.	SHAFT	1
39	CE3205	VIISTOKUULALAAKERI 3205A 2 Rs	BEARING	1
40	22732	PULTATTAVA LAIPPA HITSATTU	FLANGE	1

1.10 SYÖTTÖKOTELO, SIEMEN FEEDING HOPPER, SEED

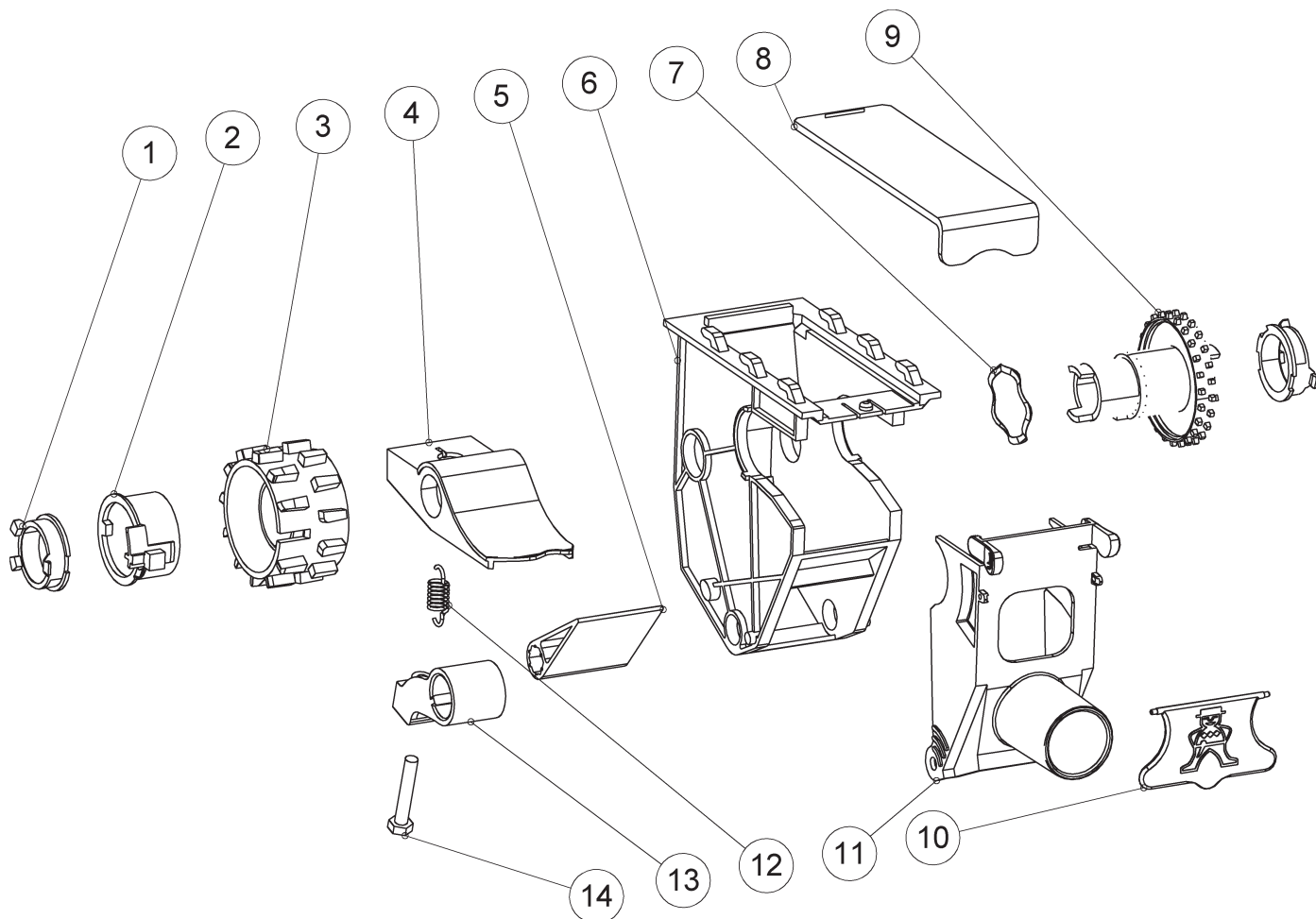

OSA PART	KOODI CODE	NIMITYS	DESCRIPTION	KPL/PCS
1	17110	SYÖTTÖRULLAN LAAKERI	BEARING	2
2	17109	LIITOSKAPPELE	JOINT PART	1
3	17107	ENSIÖSYÖTTÖRULLA	FEEDER WHEEL	1
4	17104	POHJALÄPPÄ	BOTTOM FLAP	1
5	17103	VAIHTOLÄPPÄ	SHIFT FLAP	1
6	17101	SYÖTTÖKOTELO	FEEDING HOPPER	1
7	17490	JOUSIPRIKKA SYÖTTÖL.	SPRING WASHER	1
8	17102	SULKULUUKKU	CLOSING FLAP	1
9	17108	TOISIOSYÖTTÖRULLA	SECONDARY FEEDER WHEEL	1
10	18821	PIKKULUUKKU	LITTLE FLAP	1
11	17106	SYÖTTÖLAITTEEN LUUKKU	SHUTTER	1
12	17144	POHJALÄPÄN JOUSI	SPRING FOR BOTTOM FLAP	1
13	17105	POHJALÄPÄN SISÄHOLKKI	INNER SOCKET FOR BOTTOM FLAP	1
14	A06151514	6-RUUVI M6X35 8.8 DIN 933 ZN SCREW		1

1.11 SYÖTTÖKOTELO, LANNOITE FEEDING HOPPER, FERTILIZER

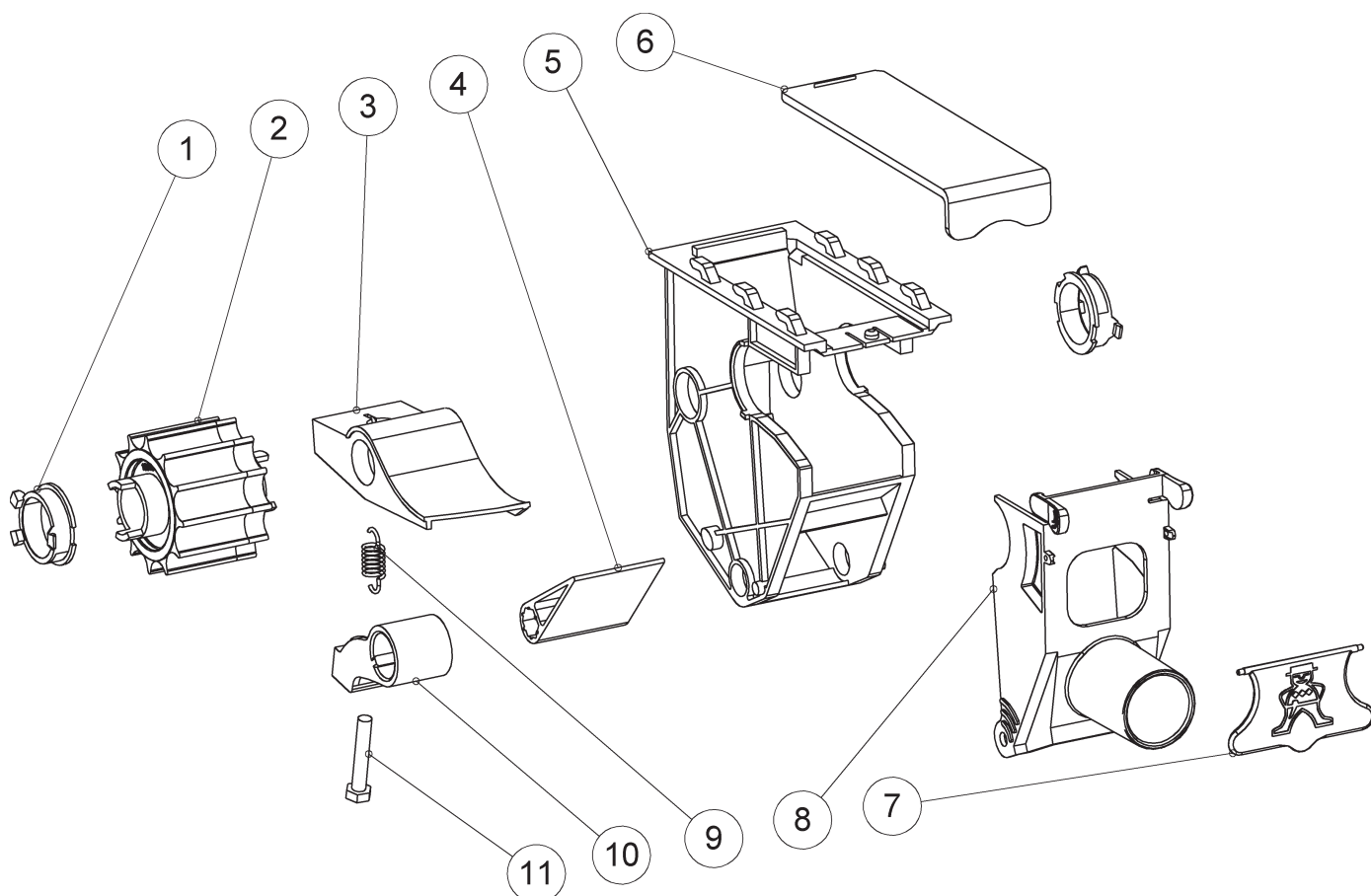

OSA PART	KOODI CODE	NIMITYS	DESCRIPTION	KPL/PCS
1	17110	SYÖTTÖRULLAN LAAKERI	BEARING	2
2	18518	LANNOITESYÖTTÖRIHLA	JOINT PART	1
3	18520	LANNOITEPUOLEN POHJALÄPPÄ	BOTTOM FLAP	1
4	17103	VAIHTOLÄPPÄ	SHIFT FLAP	1
5	17101	SYÖTTÖKOTELO	FEEDING HOPPER	1
6	17102	SULKULUUKKU	CLOSING FLAP	1
7	18821	PIKKULUUKKU	LITTLE FLAP	1
8	17106	SYÖTTÖLAITTEEN LUUKKU	SHUTTER	1
9	17144	POHJALÄPÄN JOUSI	SPRING FOR BOTTOM FLAP	1
10	17105	POHJALÄPÄN SISÄHOLKKI	INNER SOCKET FOR BOTTOM FLAP	1
11	A06151515	6-RUUVI M6X35 8.8 DIN 933 AISI	SCREW	1

1.12 RUIKUTUSURAKYTKIN TRAMLIN SWITCH

SIEMEN
SEED

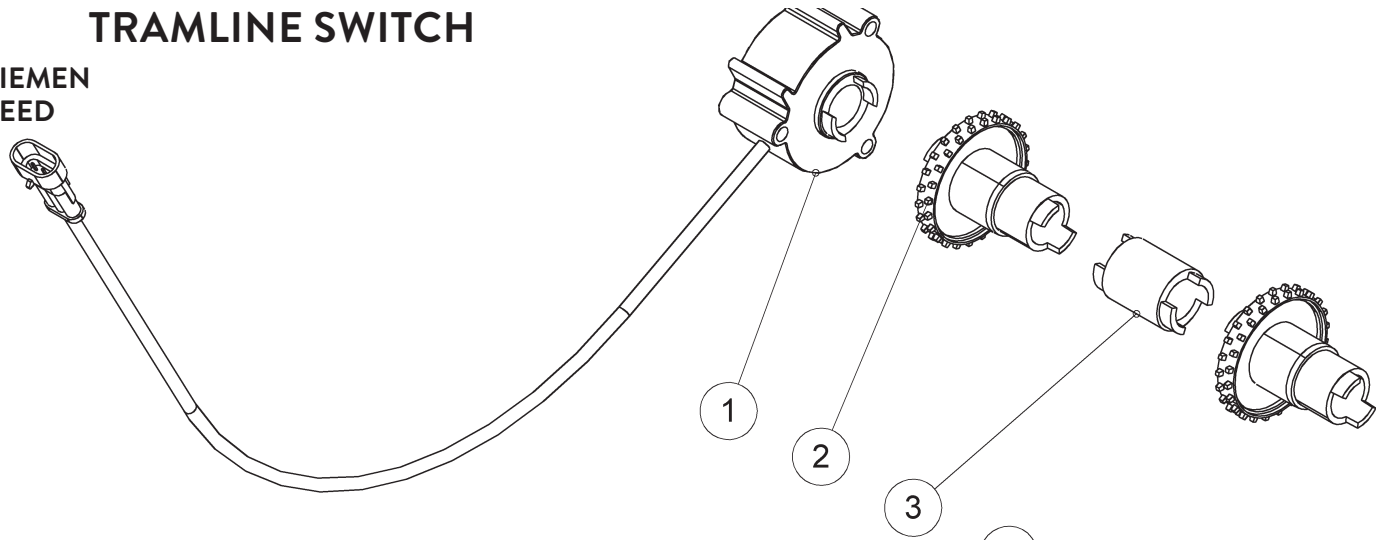

LANNOITE SAMAA RIVIIN
FERT INTO THE SAME ROW

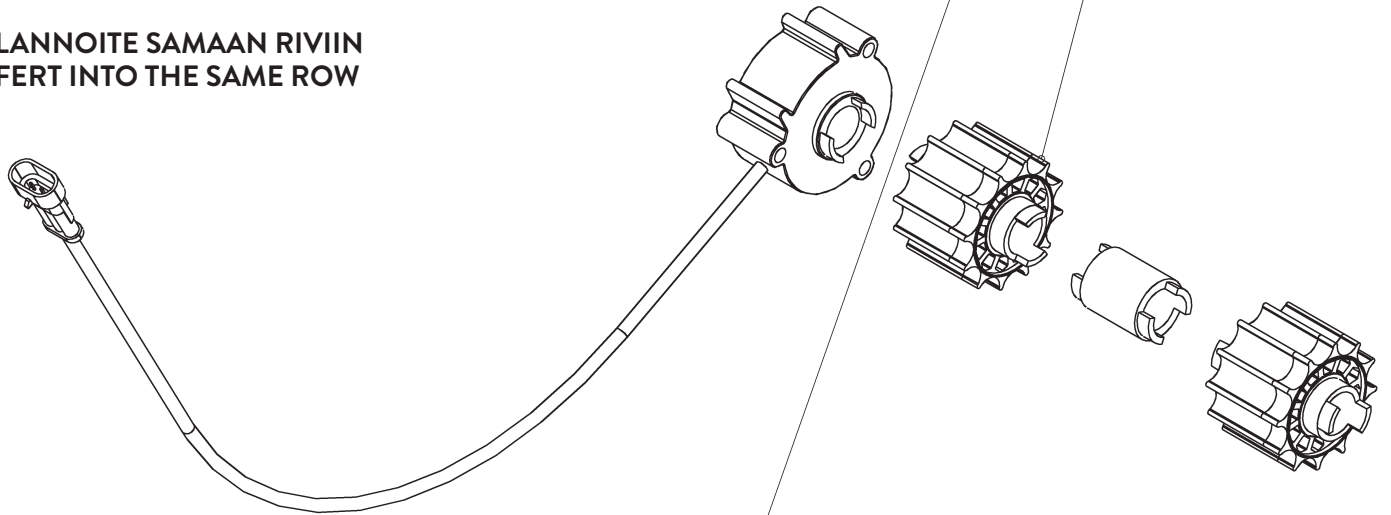

LANNOITE ERI RIVIIN
FERT INTO A SEPARATE ROW

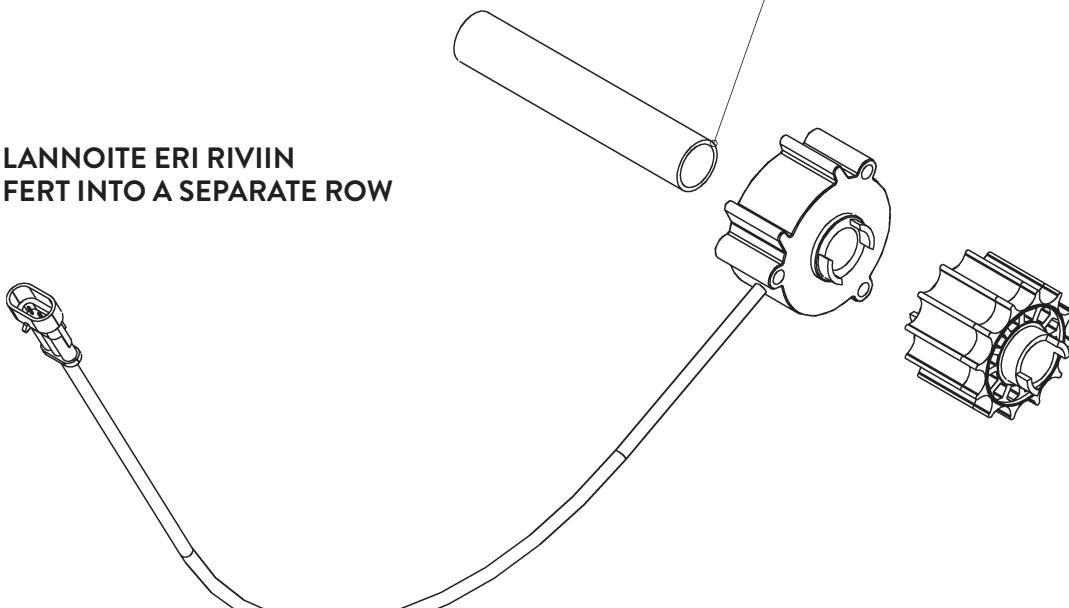

OSA PART	KOODI CODE	NIMITYS	DESCRIPTION	SIEMEN/ GRAIN	LANN. SAMAAN/ FERT. SAME	LANN. ERI/ FERT. APART
1	22964	AJOURAKYTKIN JAC 971.021.030 M	SWITCH	1	1	1
2	17974	TOISIOSYÖTTÖRULLA SORVATTU	SECONDARY FEEDER WHEEL	2		
3	17510	VÄLIHOLKKI AJOURAMERKKARILLE	BUSHING	1	1	
4	33109	VÄLIHOLKKI	BUSHING			1
5	20873	LANNOITESYÖTTÖRIHLA SORVATTU	FEEDER RIFLING WHEEL		2	1

2. RUNKO JA VANTAAT FRAME AND COULTERS

2.1 RUNKO S, LANNOITE ERI RIVIIN FRAME S, FERT INTO A SEPARATE ROW

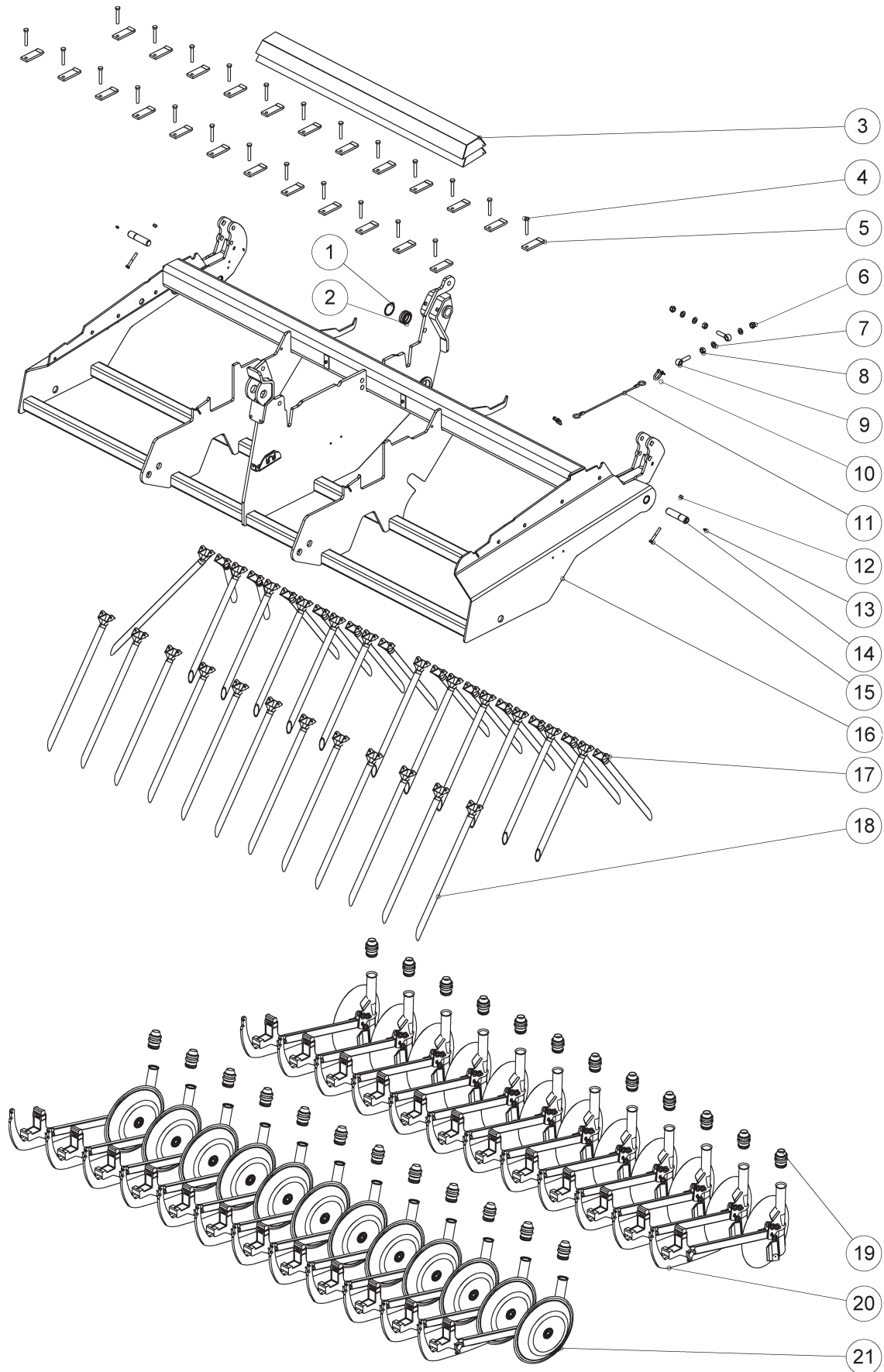

A GOOD WAY TO WORK HARD

OSA PART	KOODI CODE	NIMITYS	DESCRIPTION	S300	S400
1	BH2220021	SEGER-RENG REI 62X2 472	CIRCLIP	1	1
2	CEGE40	NIVELLAAKERI INA GE 40 DO	BEARING	1	1
3	17663	KIERTOKOEKAUKALO	CALIBRATION TRAY	2	
	18202	KIERTOKOEKAUKALO 400 HITS.	CALIBRATION TRAY		2
4	A0C2L1514	6-RUUVI M12X80 8.8 DIN931 ZN	SCREW	24	32
5	31561	KIINNITIN	HOLDER	24	32
6	AGG113014	6-MUTTERI II M16 DIN985-8 ZN	NUT	2	2
7	B5G102524	ALUSLAATTA M16 DIN125A ZN	WASHER	4	4
8	A51700	6-MUTTERI M16 DIN934-8 ZNK	NUT	2	2
9	A0G3A1014	SILMÄRUUVI DIN444 16x70	SCREW	2	2
10	BC3000002	RUUVISAKKELI M8 ZN	SHACKLE	2	2
11	33288	VAIJERI 6mm L=470mm	WIRE ROPE	1	1
12	AGA113014	6-MUTTERI II M10 DIN985-8 ZN	NUT	2	2
13	BJ6500000	RASVANIPPA M 8*1.25 N:O 507	GREASE NIPPLE	2	2
14	17289	TAPPI RUNKON PÄÄTYYN	PIVOT	2	2
15	A0A2F1514	6-RUUVI M10X75 8.8 DIN931 ZN	SCREW	2	2
16	31558	RUNKO HITS.	FRAME	1	
	33168	RUNKO S400 HITS.	FRAME		1
17	20606	SIEMENSYÖTTÖPUTKI KP	FEEDER TUBE	2	3
	20604	SIEMENSYÖTTÖPUTKI KP	FEEDER TUBE	21	29
	33534	SUPPILO VINO VAS+PUTKI 650	FEEDER TUBE, OBLIQUE	1	
18	20877	SUPPILO SUORA+PUTKI LYH LP	FEEDER TUBE	12	16
19	32485	MULTASUOJA KELTAINEN	DUST SHIELD	36	48
20	32548	1-PUTKINEN TAKAVANNAS S KP	REAR COULTER	12	16
21	32663	ETUVANNAS KP	FRONT COULTER	12	16
	33356	LANNOITEVANNAS S-PIIKI	FERTILIZER COULTER, S-TINE	12	16
	33357	LANNOITEVANNAS S KAKSOISKIEKKO	FERT COULTER, DOUBLE DISC	12	16
	33110	S LANN VANNAS KUMI VASEN KP	FERT COULTER, RUBBER LEFT	6	8
	33115	S LANN VANNAS KUMI OIKEA KP	FERT COULTER, RUBBER RIGHT	6	8

2.1.1 LANNOITEVANNAS, S-PIIKKI FERT COULTER, S-TINE

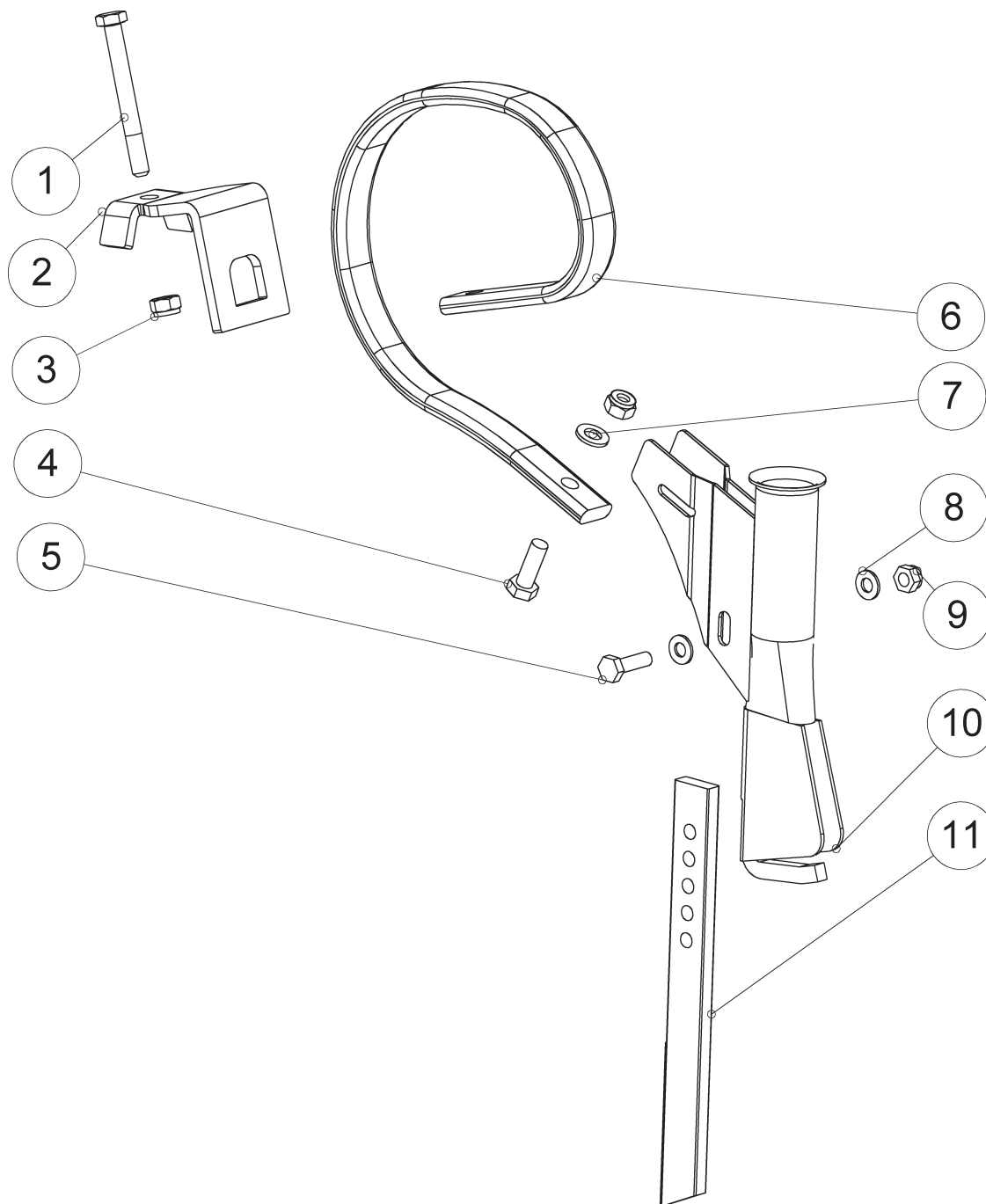

OSA PART	KOODI CODE	NIMITYS	DESCRIPTION	KPL/PCS
1	A0C3L1514	6-RUUVI M12X110 8.8 DIN 931ZN	SCREW	1
2	33286	JOUSEN KIINNITIN	SPRING HOLDER	1
3	AGC113014	6-MUTTERI II M12 DIN985-8 ZN	NUT	2
4	A0C151514	6-RUUVI M12X35 8.8 DIN933 ZN	SCREW	1
5	A0A151014	6-RUUVI M10X35 8.8 DIN933 ZN	SCREW	1
6	33285	JOUSI LANNOITEVANNAS SUOMI	SPRING	1
7	B5C0R2024	ALUSLAATTA M12 DIN125A ZN	WASHER	1
8	B5A0MB024	ALUSLAATTA M10 DIN125A ZN	WASHER	2
9	AGA113014	6-MUTTERI II M10 DIN985-8 ZN	NUT	1
10	137252	VANNASPUTKI LANN. MAALATTU	COULTER TUBE	1
11	13101	LANN.VANT.KÄRKI. M87 48625S	COULTER TOP	1
	33356	LANNOITEVANNAS S-PIIKILLÄ KOOTTU	FERTILIZER COULTER, S-TINE	

2.1.2 LANNOITEVANNAS, S-KAKSOISKIEKKO FERT COULTER, S-DOUBLE-DISC COULTER

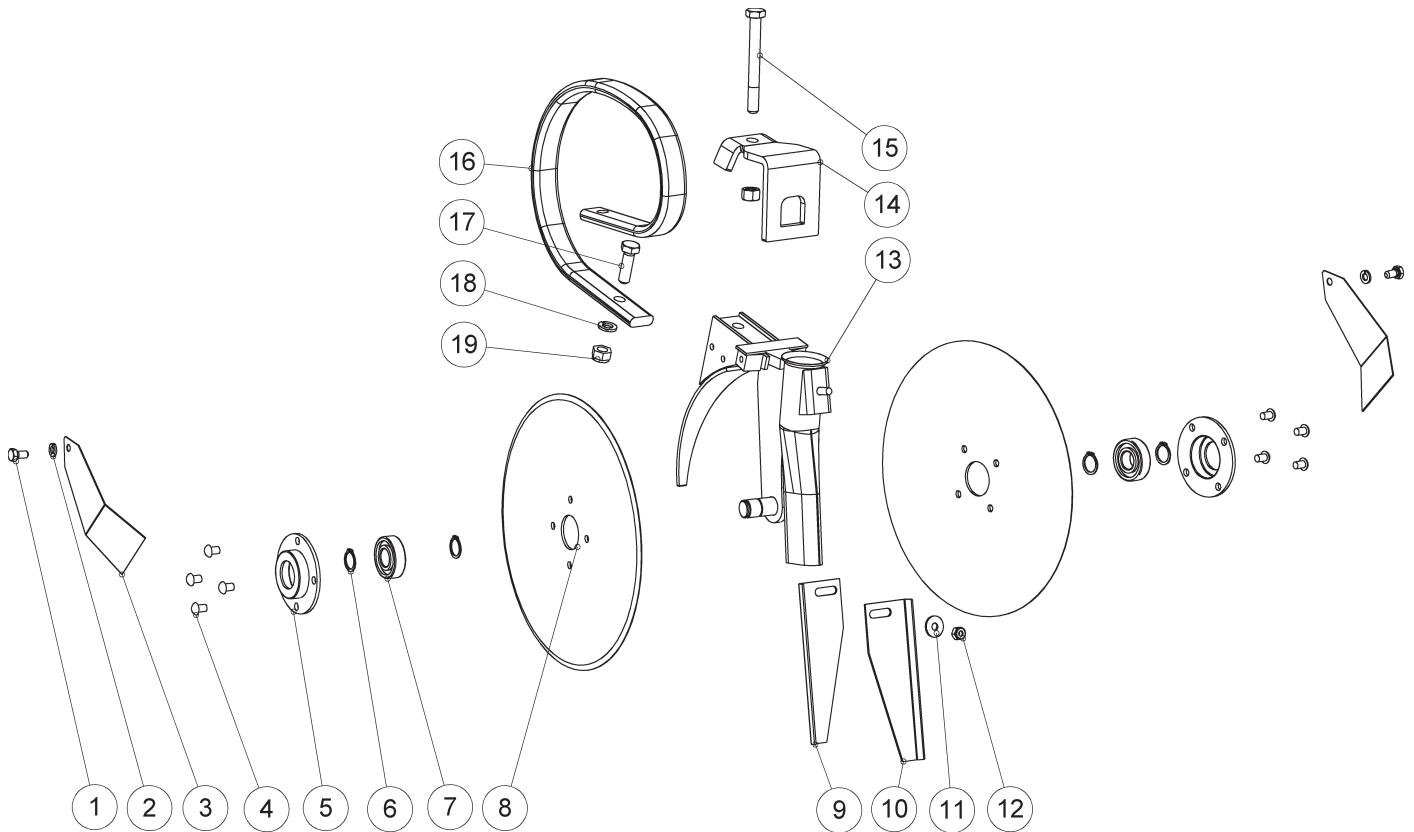

OSA PART	KOODI CODE	NIMITYS	DESCRIPTION	KPL/PCS
1	A04220	6-RUUVI M8X16 A2-80 DIN 933 AI	SCREW	2
2	B580E2015	JOUSIALUSLEVY M8 AISI	SPRING WASHER	2
3	16364	RAAPIJA	SCRAPER	2
4	B180C1110	NIITTI KUPUK. 8X12 DIN660 ST	RIVET	8
5	10732	LAAKERIPESÄ VANNASKIEKKOON	BEARING HOUSING	2
6	BH0112014	SEGER-RENG AKS 20X1.2 471	CIRCLIP	4
7	CE62042RS	KUULALAAKERI 6204 2 RS	BEARING	2
8	10731	KIEKKO LANNOITEVANT.M-JAPANI	COULTER DISC	2
9	10726	TAKAPELTI LANN.VANT.JAPANI	REAR PLATE	1
10	16509	TAKAPELTI LANN.VANT.JAPANI	REAR PLATE	1
11	B5A0V1525	KORILAATTA M8 DIN9021 A2	WASHER	1
12	A50710	6-MUTTERI II M8 A2 DIN985 AISI	NUT	1
13	16425	LANN.VANTAAN	COULTER TUBE	1
14	33286	JOUSEN KIINNITIN	SPRING HOLDER	1
15	A0C3L1514	6-RUUVI M12X110 8.8 DIN931ZN	SCREW	1
16	33368	JOUSI LANNOITEVANNAS JAPANI	SPRING	1
17	A0C1A1014	6-RUUVI M12X40 8.8 DIN933 ZN	SCREW	1
18	B5C0M2514	JOUSIALUSL.M12 DIN127B ZN	SPRING WASHER	1
19	AGC113014	6-MUTTERI II M12 DIN985-8 ZN	NUT	2
	33357	LANN.VANNAS S-KAKSOISKIEKKO KP.	FERT COULTER, DOUBLE DISC	

2.1.3 LANNOITEVANNAS S
FERT COULTER S

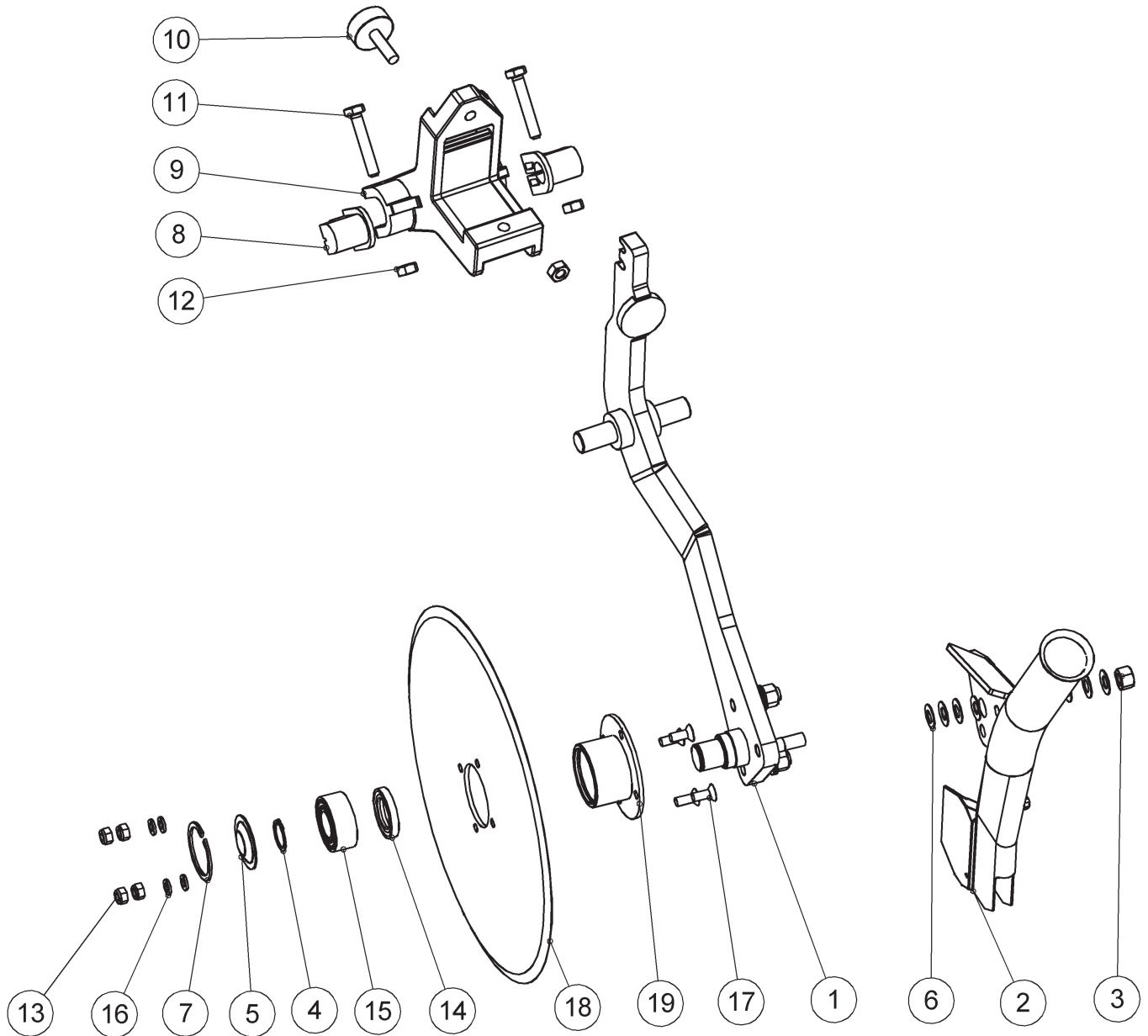

A GOOD WAY TO WORK HARD

OSA PART	KOODI CODE	NIMITYS	DESCRIPTION	VAS./ LEFT	OIK./ RIGHT
1	36613	LANN. VANTAAN VARSIVASEN	COULTER ARM, LEFT	1	
	36589	LANN. VANTAAN VARSIOIKEA	COULTER ARM, RIGHT		1
2	36596	PUTKI HITS. VAS. LANN.VANNAS	COULTER TUBE, LEFT	1	
	36593	PUTKI HITS. OIK. LANN.VANNAS	COULTER TUBE, RIGHT		1
3	AGC113014	6-MUTTERI II M12 Din985-8 Zn	NUT	3	3
4	BH0S10S14	SEGER-RENG AKS 25X1.2 471	CIRCLIP	1	1
5	31284	SUOJALEVY 51mm	COVER PLATE	1	1
6	B61473	LAUTASJOUSI Ø23/Ø12.2*1	SPRING	21	21
7	BH1N20021	SEGER-RENG REI 52X2 472	CIRCLIP	1	1
8	17162	MUOVILAAKERI VANTAASEEN	PLASTIC BEARING	2	2
9	17118	VANTAAN KIINNITIN	COULTER HOLDER	1	1
10	D40001548	LIERIÖPUSKIN 40*15	BUFFER	1	1
11	A0A201014	6-RUUVI M10X60 8.8 Din931 Zn	SCREW	2	2
12	AGA113014	6-MUTTERI II M10 Din985-8 Zn	NUT	3	3
13	AG8113014	6-MUTTERI II M 8 Din985-8 Zn	NUT	4	4
14	CNA304770	STEFA Din 3760 A30*47*7	SHAFT SEAL	1	1
15	CE3205	VIISTOKUULALAAKERI 3205A 2 R _s	BEARING	1	1
16	B580E2014	JOUSIALUSLAAT. .M 8 Din127B Zn	WASHER	4	4
17	A080L4511	6-KOLOR.UPP.M8X20 10.9Din7991	SCREW	4	4
18	31357	KIEKKO 14"	COULTER DISC	1	1
19	31356	VANTAAN NAPA	HUB	1	1
	36590	LANN.VANNAS OIK. KP	FERT COULTER, RIGHT		
	36610	LANN.VANNAS VAS. KP	FERT. COULTER, LEFT		

2.2 RUNKO S, COMBI FRAME S, COMBI

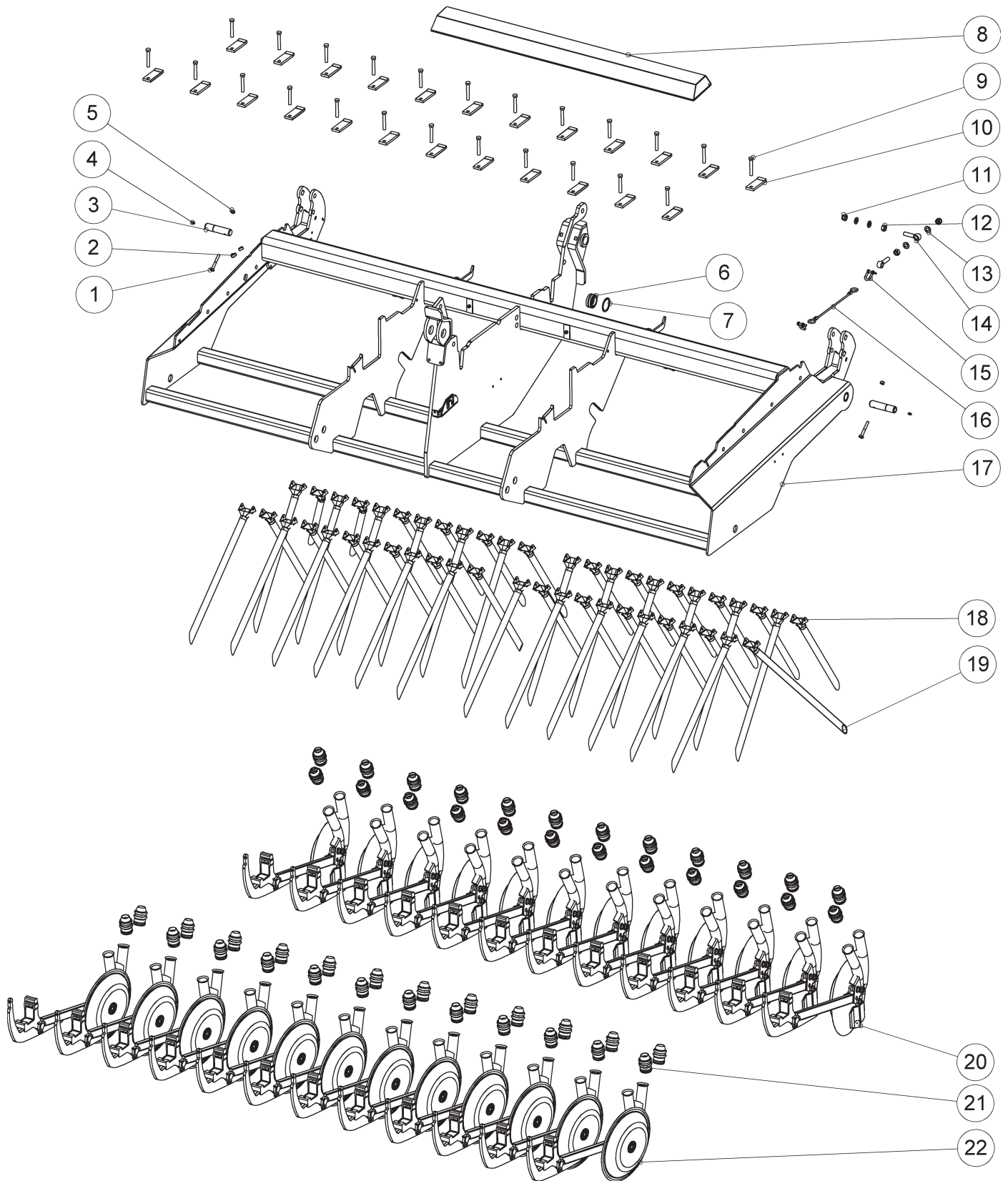

A GOOD WAY TO WORK HARD

OSA PART	KOODI CODE	NIMITYS	DESCRIPTION	S300	S400
1	A0A2F1514	6-RUUVI M10X75 8.8 DIN931 ZN	SCREW	2	2
2	13445	HOLKKI KETJUNKIRISTÄJÄÄN	SPACER	2	2
3	17289	TAPPI RUNGON PÄÄTYYN	PIVOT	2	2
4	BJ6500000	RASVANIPPA M 8*1.25 N:O 507	GREASE NIPPLE	2	2
5	AGA113014	6-MUTTERI II M10 DIN985-8 ZN	NUT	2	2
6	CEGE40	NIVELLAAKERI INA GE 40 DO	BEARING	1	1
7	BH2220021	SEGER-RENG REI 62X2 472	CIRCLIP	1	1
8	17663	KIERTOKOEKAUKALO	CALIBRATION TRAY	2	
	18202	KIERTOKOEKAUKALO 400 HITS.	CALIBRATION TRAY		2
9	A0C2L1514	6-RUUVI M12X80 8.8 DIN931 ZN	SCREW	24	32
10	31561	KIINNITIN	HOLDER	24	32
11	AGG113014	6-MUTTERI II M16 DIN985-8 ZN	NUT	2	2
12	A51700	6-MUTTERI M16 DIN934-8 ZNK	NUT	2	2
13	B5G102524	ALUSLAATTA M16 DIN125A ZN	WASHER	4	4
14	A0G3A1014	SILMÄRUUVI DIN444 16x70	SCREW	2	2
15	BC3000002	RUUVISAKKELI M8 ZN	SHACKLE	2	2
16	20652	VAIJERI 6mm-400mm	WIRE ROPE	1	1
17	31558	RUNKO HITS.	FRAME	1	
	33168	RUNKO S400 HITS.	FRAME		1
18	20606	SIEMENSYÖTTÖPUTKI KP	FEEDER TUBE	2	2
	20877	SUPPILO SUORA+PUTKI LYH LP	FEEDER TUBE	12	15
	20604	SIEMENSYÖTTÖPUTKI KP	FEEDER TUBE	10	14
	33149	LANN.SYÖTTÖPUTKI VINO L=650	FEEDER TUBE		1
19	20877	SUPPILO SUORA+PUTKI LYH LP	FEEDER TUBE	12	16
	20878	SUPPILO SUORA+PUTKI PIT LP	FEEDER TUBE	11	15
	33482	LANN.SYÖTTÖPUTKI VINO L=750 VA	FEEDER TUBE	1	1
20	32546	2-PUTKINEN TAKAVANNAS S KP	REAR COULTER 2-TUBE	12	16
21	32485	MULTASUOJA KELTAINEN	DUST SHIELD	48	64
22	32653	ETUVANNAS KP 2-PUTKINEN	FRONT COULTER 2-TUBE	12	16

2.3 RUNKO S, SEED FRAME S, SEED

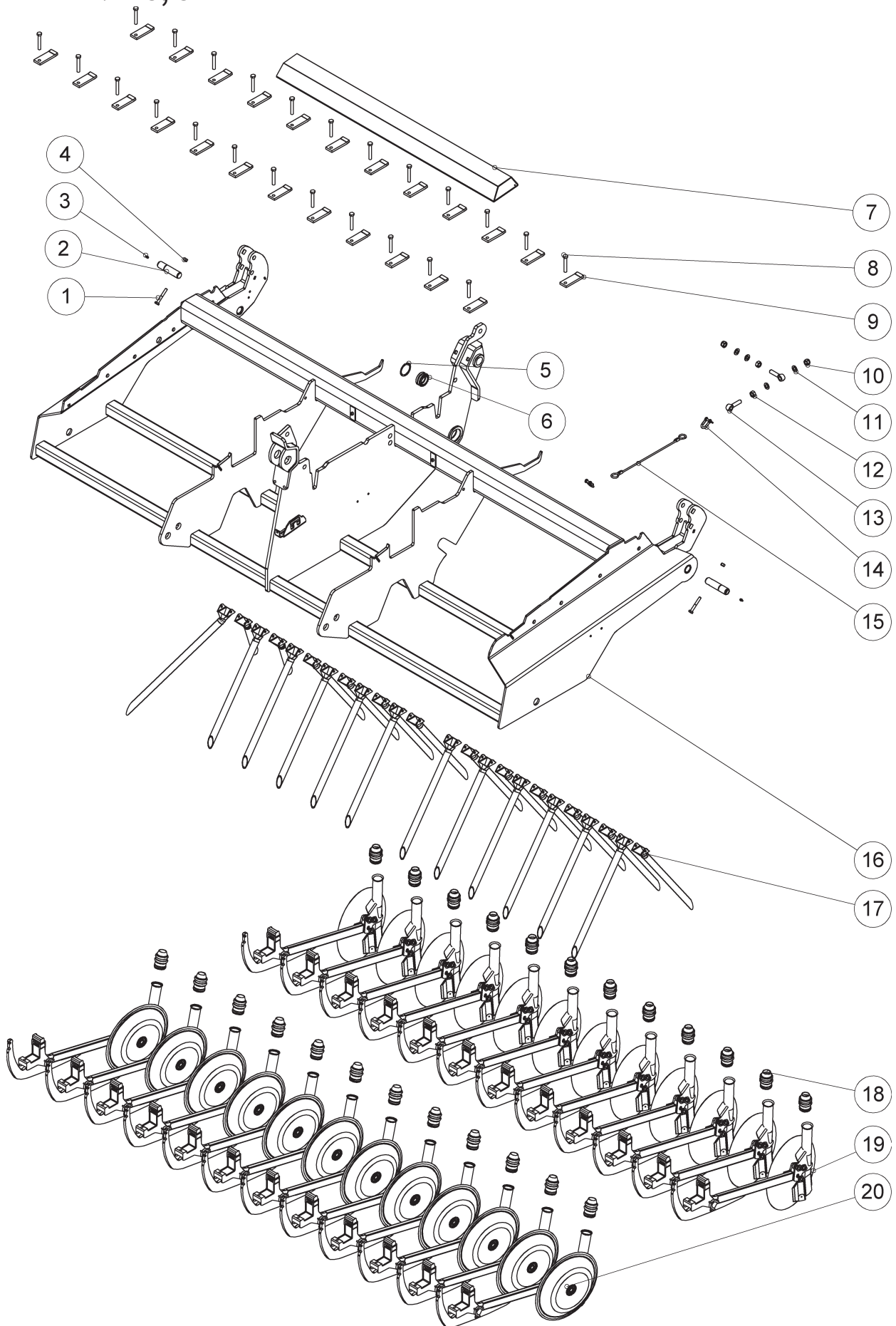

A GOOD WAY TO WORK HARD

OSA PART	KOODI CODE	NIMITYS	DESCRIPTION	S300	S400
1	A0A2F1514	6-RUUVI M10X75 8.8 DIN931 ZN	SCREW	2	2
2	17289	TAPPI RUNGON PÄÄTYYN	PIVOT	2	2
3	BJ6500000	RASVANIPPA M 8*1.25 N:O 507	GREASE NIPPLE	2	2
4	AGA113014	6-MUTTERI II M10 DIN985-8 ZN	NUT	2	2
5	BH2220021	SEGER-RENG REI 62X2 472	CIRCLIP	1	1
6	CEGE40	NIVELLAAKERI INA GE 40 DO	BEARING	1	1
7	17663	KIERTOKOEKAUKALO	CALIBRATION TRAY	2	
	18202	KIERTOKOEKAUKALO 400 HITS.	CALIBRATION TRAY		2
8	A0C2L1514	6-RUUVI M12X80 8.8 DIN931 ZN	SCREW	24	32
9	31561	KIINNITIN	HOLDER	24	32
10	AGG113014	6-MUTTERI II M16 DIN985-8 ZN	NUT	2	2
11	B5G102524	ALUSLAAATTA M16 DIN125A ZN	WASHER	4	4
12	A51700	6-MUTTERI M16 DIN934-8 ZNK	NUT	2	2
13	A0G3A1014	SILMÄRUUVI DIN444 16x70	SCREW	2	2
14	BC3000002	RUUVISAKKELI M8 ZN	SHACKLE	2	2
15	33288	VAIJERI 6mm L=470mm	WIRE ROPE	1	1
16	31558	RUNKO HITS.	FRAME	1	
	33168	RUNKO S400 HITS.	FRAME		1
17	20606	SIEMENSYÖTTÖPUTKI KP	FEEDER TUBE	2	3
	20604	SIEMENSYÖTTÖPUTKI KP	FEEDER TUBE	21	29
	33534	SUPPILO VINO VAS+PUTKI 650	FEEDER TUBE	1	
18	32485	MULTASUOJA KELTAINEN	DUST SHIELD	24	32
19	32548	1-PUTKINEN TAKAVANNAS S KP	REAR COULTER	12	16
20	32663	ETUVANNAS KP	FRONT COULTER	12	16

2.4 SIEMENVANNAS S SEED COULTER S

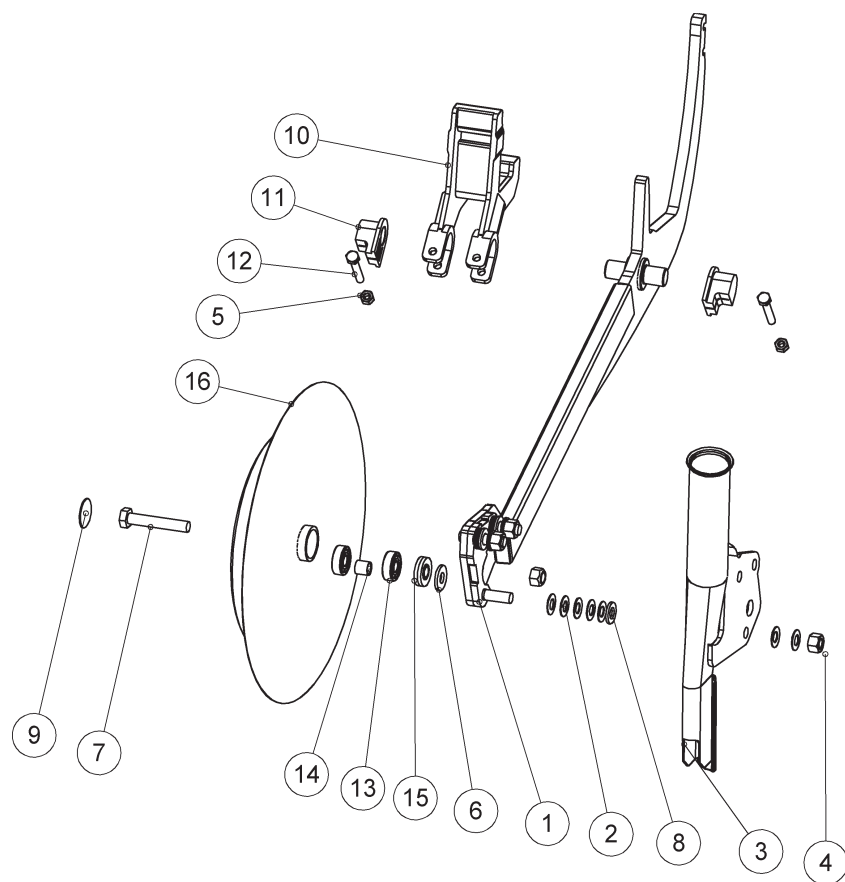

OSA PART	KOODI CODE	NIMITYS	DESCRIPTION	ETU/ FRONT	TAKA/ REAR
1	36621 36632	VARSII HITS. ETUVANNAS VARSII HITS. TAKAVANNAS	COULTER ARM, FRONT COULTER ARM, REAR	1	1
2	B61473	LAUTASJOUSSI Ø23/Ø12.2*1	SPRING	21	21
3	36623 36634 36643 36657	PUTKI HITS. 1-PUTKINEN ETU PUTKI HITS. 1-PUTKINEN TAKA PUTKET HITS. 2-PUTKINEN ETU PUTKETHITS. 2-PUTKINEN TAKA	COULTER 1-TUBE COULTER 1-TUBE COULTER 2-TUBE COULTER 2-TUBE	1	1
4	AGC113014	6-MUTTERI II M12 Din985-8 Zn	NUT	4	4
5	AG8113014	6-MUTTERI II M 8 Din985-8 Zn	NUT	2	2
6	131328000	VÄLILEVY VANT LAAKEROINTIIN	PLATE	1	1
7	A09766	6-RUUVI M12X70 10.9 Din931	SCREW	1	1
8	B5C0R2024	ALUSLAATTA M12 Din125A Zn	WASHER	3	3
9	131324000	SUOJAKUPPI VANTAAN LAAKERIPES.	COVER PLATE	1	1
10	31784	VANTAAN KIINNITIN	COULTER HOLDER	1	1
11	31786	MUOVILAAKERI	PLASTIC BEARING	2	2
12	A081S1014	6-RUUVI M8X55 8.8 Din 931Znc	SCREW	2	2
13	CE6201000	KUULALAAKERI 6201 2RS	BEARING	2	2
14	D131326000	VÄLIHOLKKI KARKAISTU 2659S	BUSHING	1	1
15	131100	Z-LAMELLIPARI KOOTTU	SEGMENT	1	1
16	36108	S SIEMENVANNASKIEKKO HITS.	COURTER DISC	1	1
	V36158	S SIEMENVANNASKIEKKO KP	COULTER DISC		
	36645	SIEMENVANN. ETU, 1- PUTKINEN KP	COULTER FRONT, 1-TUBE		
	36690	SIEMENVANN. ETU, 2- PUTKINEN KP	COULTER FRONT, 2-TUBE		
	36635	SIEMENVANN. TAKA, 1- PUTKINEN KP	COULTER REAR, 1-TUBE		
	36680	SIEMENVANN. TAKA, 2- PUTKINEN KP	COULTER REAR, 2-TUBE		

2.5 VANNASPAINATUKSEN KESKUSSÄÄTÖ S, MEKAANINEN CENTRAL ADJUSTMENT OF THE COULTER PRESSURE S, MECHANICAL

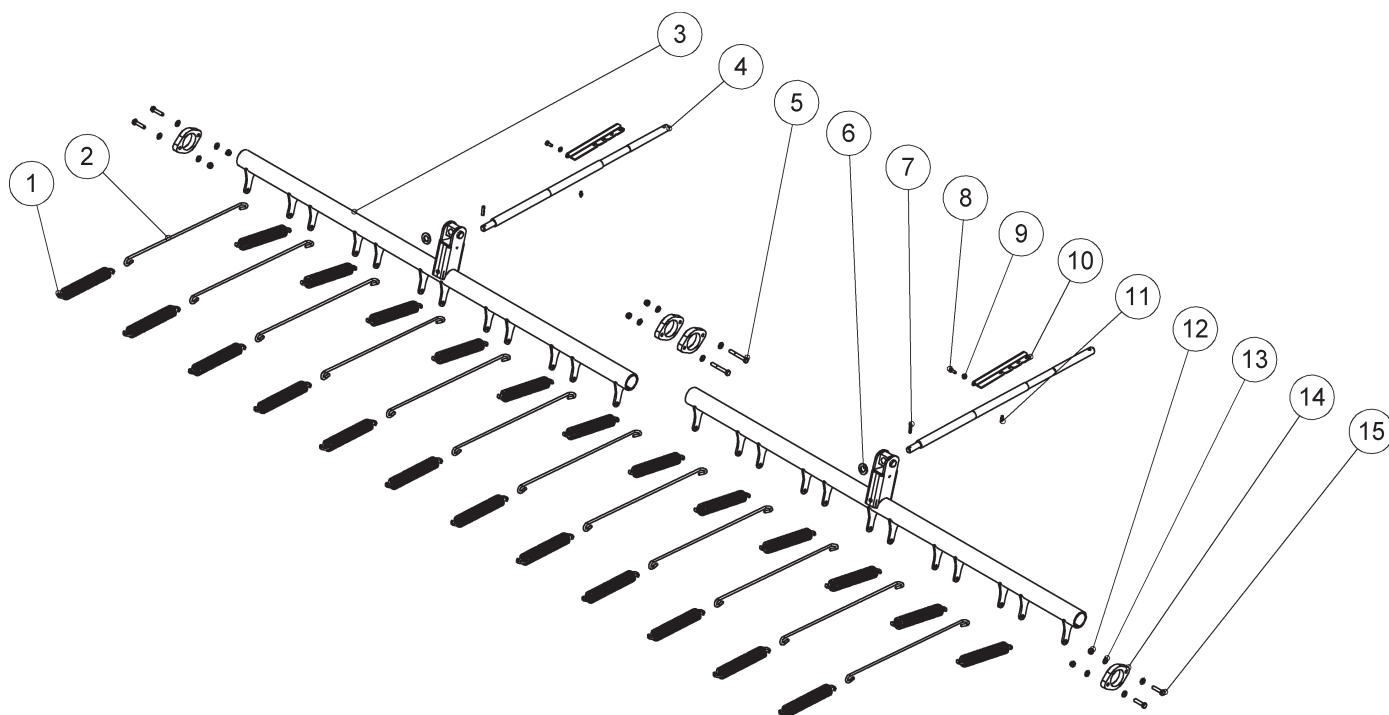

OSA PART	KOODI CODE	NIMITYS	DESCRIPTION	S300	S400
1	33019	VETOJOUSI 4.5*200	TENSION SPRING	24	32
2	33018	TANKO ETUVANTAALLE S300/400	BAR FOR FRONT COULTER	12	16
3	31521	KESKUSSÄÄDÖN PUTKI HITS S300	BAR	2	
	33171	KESKUSSÄÄDÖN PUTKI HITS.	BAR		2
4	31522	VANTAIDEN SÄÄTÖRUUVI	ADJUSTMENT SCREW	2	2
5	A05960	6-RUUVI M8X60 8.8 DIN 931 ZN	SCREW	2	2
6	B5G102524	ALUSLAATTA M16 DIN125A ZN	WASHER	2	2
7	B860T0004	JOUSISOKKA 6X26 DIN1481 ZNC	TUBULAR PIN	2	2
8	A060G1024	6-RUUVI M6X16 8.8 DIN 933 ZN	SCREW	2	2
9	B560E1524	ALUSLAATTA M 6 DIN125A ZN	WASHER	2	2
10	31526	KESKUSSÄÄDÖN ASTEIKKO	SCALE INDICATOR	2	2
11	BJ6150400	RASVANIPPA M6*1/SUORA N 504	GREASE NIPPLE	2	2
12	AG8113014	6-MUTTERI II M 8 DIN985-8 ZN	NUT	6	6
13	B580H1624	ALUSLAATTA M 8 DIN125A ZN	WASHER	12	12
14	33349	AKSELIN KIINNITIN	SHAFT HOLDER	4	4
15	A08151514	6-RUUVI M8X35 8.8 DIN 933 ZN	SCREW	4	4

2.6 VANNASPAINATUKSEN KESKUSSÄÄTÖ S, HYDRAULINEN CENTRAL ADJUSTMENT OF THE COULTER PRESSURE S, HYDRAULIC

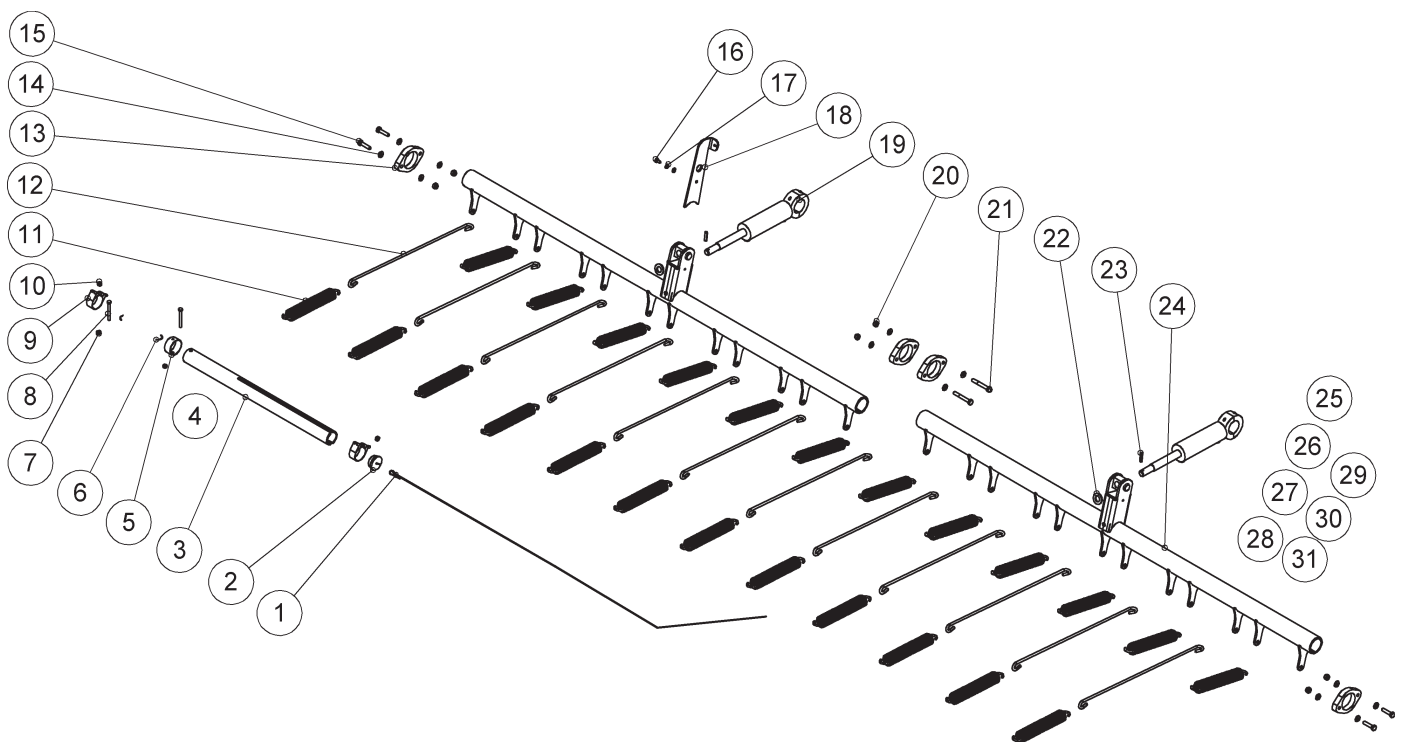

A GOOD WAY TO WORK HARD

OSA PART	KOODI CODE	NIMITYS	DESCRIPTION	S300	S400
1	33064	VETOVAIJERI	DRAW-WIRE ROPE	1	1
2	33338	NYLONHOLKKI	BUSHING NYLON	1	1
3	33058	PUTKI	BAR	1	1
4	330600	ASTEIKKOTARRA	SCALE STICKER	1	1
5	33059	OSOITIN HOLKKI	INDICATOR BUSHING	1	1
6	33063	VETOJOUSI 150*1,5	TENSION SPRING	1	1
7	AG6113014	6-MUTTERI II M 6 DIN985-8 ZN	NUT	2	2
8	A03558	6-RUUVI M6X55 8.8 DIN 933 ZN	SCREW	2	2
9	134984P	LETKUKIRISTIN PA-RI 1-45	TIGHTENER	2	2
10	AG6111014	6-MUTTERI M 6 DIN934-8 ZN	NUT	2	2
11	33019	VETOJOUSI 4.5*200	TENSION SPRING	24	32
12	33018	TANKO ETUVANTAALLE S300/400	BAR FOR FRONT COULTER	12	16
13	33349	AKSELIN KIINNITIN	SHAFT HOLDER	4	4
14	B580H1624	ALUSLAATTA M 8 DIN125A ZN	WASHER	12	12
15	A08151514	6-RUUVI M8X35 8.8 DIN 933 ZN	SCREW	4	4
16	A060C1024	6-RUUVI M6X12 8.8 DIN 933 ZN	SCREW	2	2
17	B560E1524	ALUSLAATTA M 6 DIN125A ZN	WASHER	3	3
18	33447	VAIJERIN PIDIN	WIRE HOLDER	1	1
19	33366	KESKUSSÄÄDÖNSYLINTERI S	CYLINDER	2	2
20	AG8113014	6-MUTTERI II M 8 DIN985-8 ZN	NUT	6	6
21	A05960	6-RUUVI M8X60 8.8 DIN 931 ZN	SCREW	2	2
22	B5G102524	ALUSLAATTA M16 DIN125A ZN	WASHER	2	2
23	B860T0004	JOUSISOKKA 6X26 DIN1481 ZNC	TUBULAR PIN	2	2
24	31521	KESKUSSÄÄDÖN PUTKI HITS S300	BAR	2	
	33171	KESKUSSÄÄDÖN PUTKI HITS.	BAR		2
25	133300P	USIT-TIIVISTE 217-06 3/8	SEAL	8	8
26	133472P	BANJO BSPP 3/8/3/8	BANJO CONNECTOR	4	4
27	133056P	BANJORUUVI R 3/8 181-06	BANJO SCREW	4	4
28	32801	LET 1/4 1500R3/8SR1/4S	HOSE	4	4
29	134705P	T-NIPPA 702-04 1/4	T-NIPPLE	2	2
30	D7074	JATKONIPPA 707-04	EXTENSION NIPPLE	2	2
31	D15312	HYD. LETKU SYLINT.L4600 3-15312	HOSE	2	2

2.7 RUNKO M, LANNOITE ERI RIVIIN/SEED FRAME M, FERT INTO A SEPARATE ROW/SEED

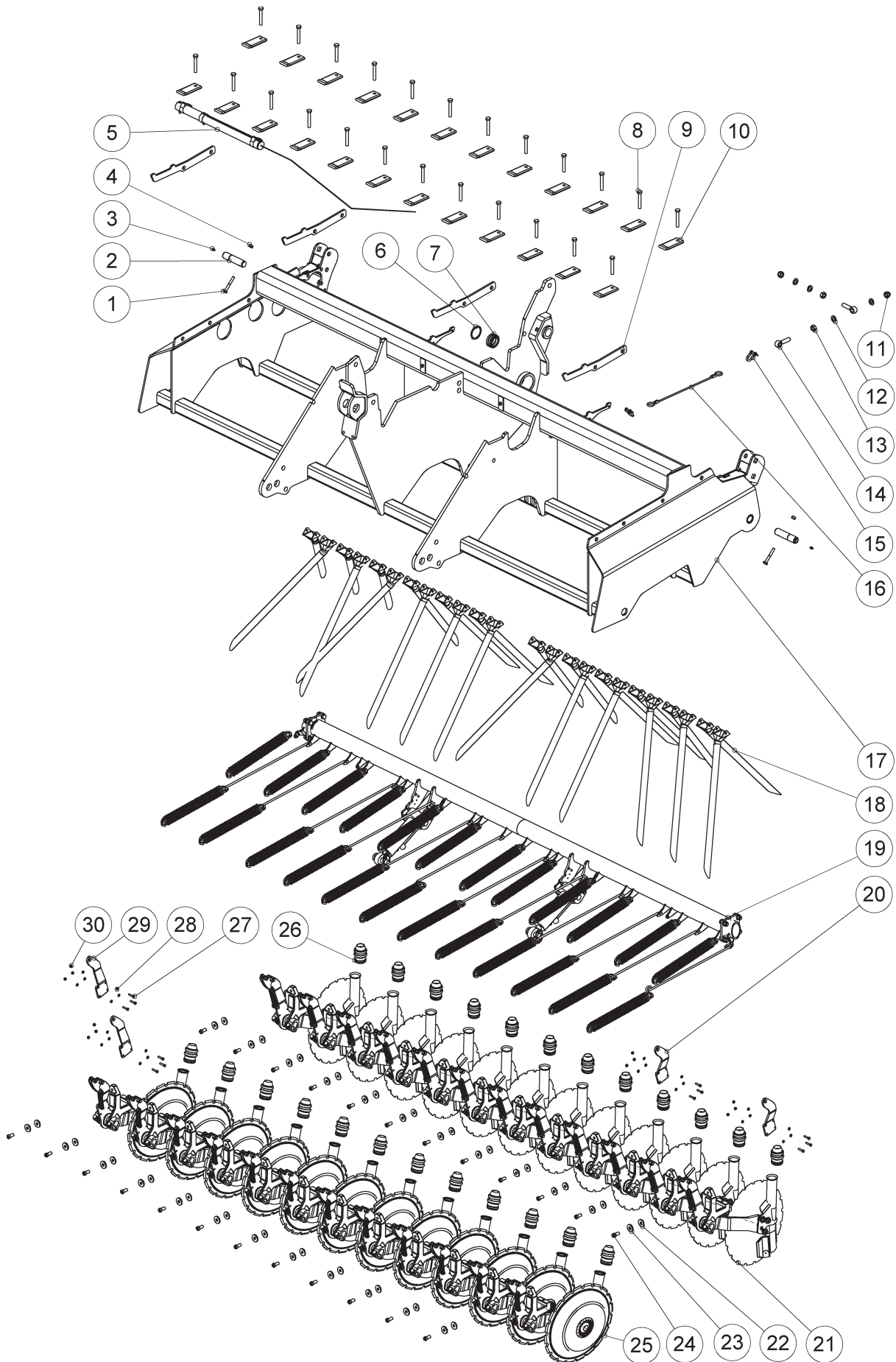

A GOOD WAY TO WORK HARD

OSA PART	KOODI CODE	NIMITYS	DESCRIPTION	M300	M400
1	A0A2F1514	6-RUUVI M10X75 8.8 DIN931 ZN	SCREW	2	2
2	17289	TAPPI RUNGON PÄÄTYYN	PIVOT	2	2
3	BJ6500000	RASVANIPPA M 8*1.25 N:O 507	GREASE NIPPLE	2	2
4	AGA113014	6-MUTTERI II M10 DIN985-8 ZN	NUT	2	2
5	33060	KESKUSSÄÄDÖN OSOITIN	CENTRAL ADJUSTMENT INDICATOR	1	1
6	BH2220021	SEGER-RENG REI 62X2 472	CIRCLIP	1	1
7	CEGE40	NIVELLAAKERI INA GE 40 DO	BEARING	1	1
8	A0C2L1514	6-RUUVI M12X80 8.8 DIN931 ZN	SCREW	24	32
9	31965	KIERTOKOEKAUKALON PIDIN	CALIBRATION TRAY HOLDER	4	4
10	17576	KIINNITIN	HOLDER	24	32
11	AGG113014	6-MUTTERI II M16 DIN985-8 ZN	NUT	2	2
12	B5G102524	ALUSLAATTA M16 DIN125A ZN	WASHER	4	4
13	A51700	6-MUTTERI M16 DIN934-8 ZNK	NUT	2	2
14	A0G3A1014	SILMÄRUUVI DIN444 16x70	SCREW	2	2
15	BC3000002	RUUVISAKKELI M8 ZN	SHACKLE	2	2
16	33288	VAIJERI 6mm L=470mm	WIRE ROPE	1	1
17	31616	RUNKO HITS. M300	FRAME	1	
	31980	M400 RUNKO HITS.	FRAME		1
18	20879	SUPPILO VINO+PUTKI LYH LP	FEEDER TUBE	3	3
	20877	SUPPILO SUORA+PUTKI LYH LP	FEEDER TUBE	6	9
	33576	SUPPILO VINO VAS+PUTKI 480	FEEDER TUBE	5	5
	20605	SIEMENSYÖTTÖPUTKI KP	FEEDER TUBE	4	7
	20607	SIEMENSYÖTTÖPUTKI KP	FEEDER TUBE	3	4
	33534	SUPPILO SUORA+PUTKI LYH LP	FEEDER TUBE	3	4
19	31930	M300 KESKUSSÄÄTÖ	CENTRAL ADJUSTMENT	1	
	31982	M400 KESKUSSÄÄTÖ	CENTRAL ADJUSTMENT		1
20	319431	ETUVANTAAN JOUSEN LISÄKIINNITI	SPRING HOLDER	2	2
21	32652	TAKAVANNAS KP 1-PUTKINEN	REAR COULTER	12	16
22	22231	RIKKA 13/35-5 DIN6340	WASHER	24	32
23	210724000	ALUSLEVY 4*35/12.2	WASHER	24	32
24	A02807	6-RUUVI. M6X30 8.8 DIN 933 ZN	SCREW	12	12
25	32667	ETUVANNAS KP 1-PUTKINEN	FRONT COULTER	12	16
26	32485	MULTASUOJA KELTAINEN	DUST SHIELD	24	32
27	A0C0S4524	6-KOLOR.M12X25 8.8 DIN912 ZN	SCREW	24	32
28	B560E1524	ALUSLAATTA M 6 DIN125A ZN	WASHER	24	24
29	319401	TAKAVANTAAN JOUSEN LISÄKIINNIT	SPRING HOLDER	2	2
30	AG6113014	6-MUTTERI II M 6 DIN985-8 ZN	NUT	12	12
	31201	LANNOITEVANTAISTO M 300	FERTILIZER COULTER ASSEMBLY		

2.7.1 LANNOITEVANTAISTO M
FERTILIZER COULTERS

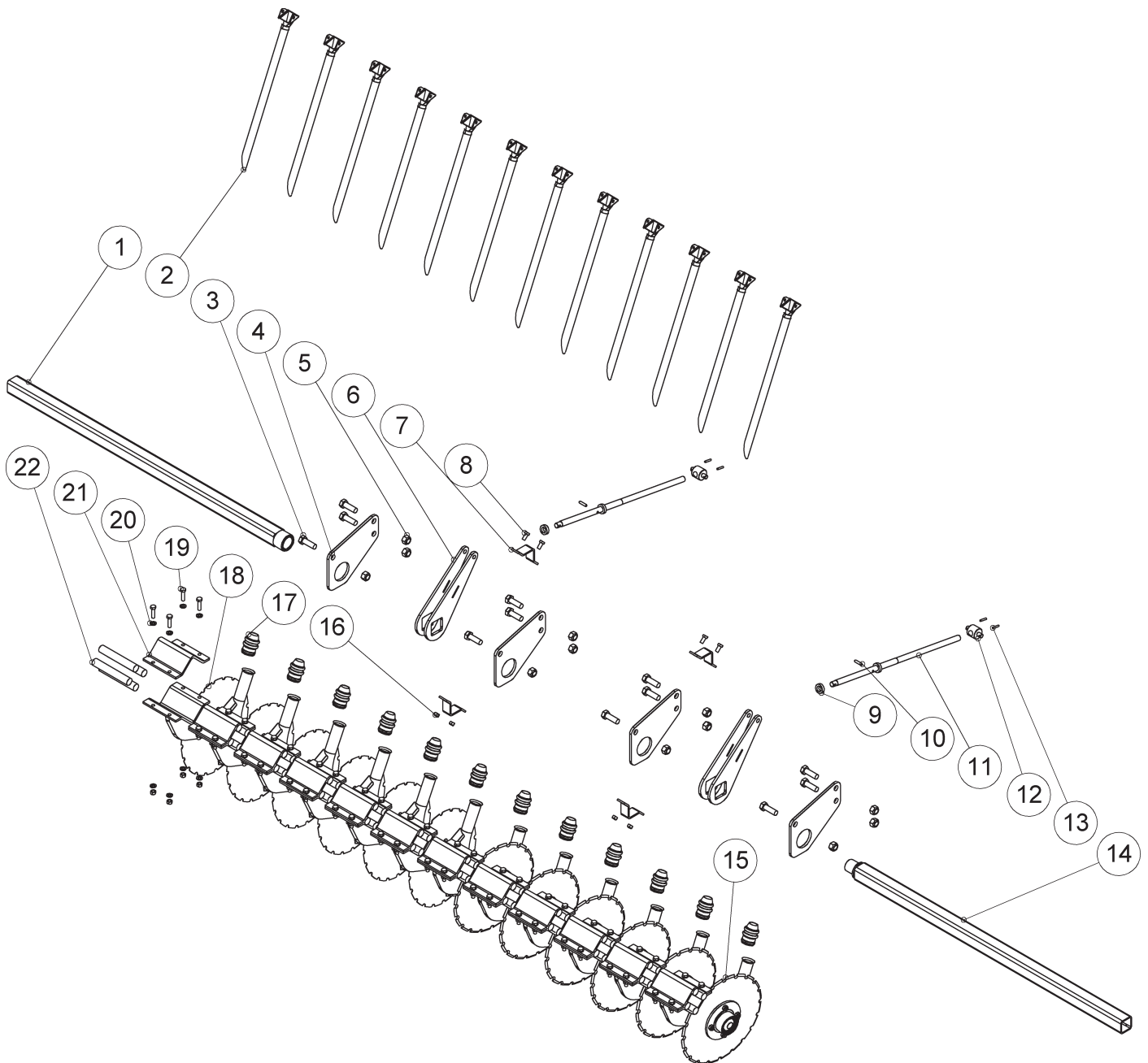

A GOOD WAY TO WORK HARD

OSA PART	KOODI CODE	NIMITYS	DESCRIPTION	M300	M400
1	31211	AKSELI VANTAILLE HOLKILLA	SHAFT	1	
	33196	AKSELI VANTAILLE HOLKILLA	SHAFT		1
2	22685	SYÖTTÖPUTKI I=540 + SUPPILO	FEEDER TUBE	12	16
3	A0L201524	6-RUUVI M20X60 8.8 DIN933 ZN	SCREW	12	12
4	17646	PALKIN KIINNIKE	HOLDER	4	4
5	AGL113014	6-MUTTERI II M20 DIN985-8 ZN	NUT	12	12
6	22784	KORVA LANNOITEAKSELILLE	FERT SHAFT HOLDER	4	4
7	17739	APULANTAVANTAIDEN PAIKOITIN	COULTER HOLDER	4	4
8	A0C0S1512	6-RUUVI M12X25 8.8 DIN933 ZN	SCREW	4	4
9	18354	KAULUS SÄÄTÖRUUVIIN KELTAPASS.	COLLAR	2	2
10	B88160001	JOUSISOKKA 8X36 DIN1481 ZNC	TUBULAR PIN	2	2
11	33606	SÄÄTÖTANKO HITS.	ADJUSTMENT BAR	2	2
12	17728	SÄÄTÖSARANA	ADJUSTMENT PIVOT	2	2
13	B86120001	JOUSISOKKA 6X32 DIN1481 ZNC	TUBULAR PIN	4	4
14	31209	LANNOITEVANT AKSELI TAPILLA	SHAFT	1	
	33197	LANNOITEVANT AKSELI TAPILLA	SHAFT		1
15	33218	M LANN.VANNAS OIK. KP KUMI	FERT COULTER RUBBER, RIGHT	6	8
16	AGC113014	6-MUTTERI II M12 DIN985-8 ZN	NUT	52	68
17	32485	MULTASUOJA KELTAINEN	DUST SHIELD	12	16
18	33208	M LANN.VANNAS VAS. KP KUMI	FERT COULTER RUBBER, LEFT	6	8
19	A0C1F1024	6-RUUVI M12X45 8.8 DIN933 ZN	SCREW	52	64
20	B5C0R2024	ALUSLAATTA M12 DIN125A ZN	WASHER	96	128
21	22197	KIINNITIN MAALATTU	HOLDER	12	16
22	22307	KUMIPATUKKA	RUBBER STICK	48	64

2.7.2 LANNOITEVANNAS M
FERTILIZER COULTER M

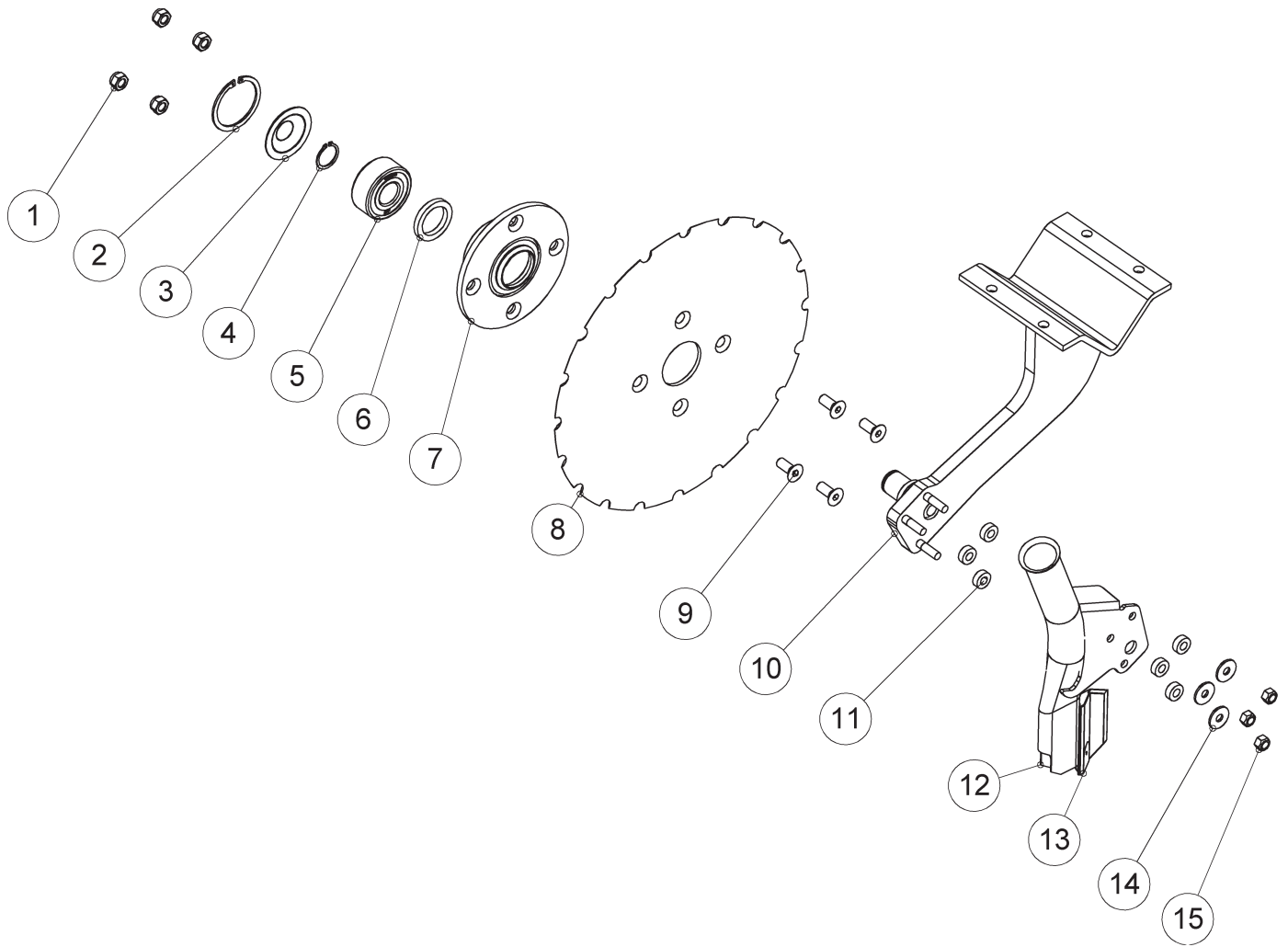

A GOOD WAY TO WORK HARD

OSA PART	KOODI CODE	NIMITYS	DESCRIPTION	OIK./ RIGHT	VAS./ LEFT
1	AGC113014	6-MUTTERI II M12 DIN985-8 ZN	NUT	4	4
2	BH2C21L14	SEGER-RENG REI 72X2.5 472	CIRCLIP	1	1
3	21095	SUOJALEVY	COVER PLATE	1	1
4	BH1011L11	SEGERRENG AKS 30X1.5 471	CIRCLIP	1	1
5	CE33062RSSKF	2-RIV. VIISTOKUULALAAK. 33062R	BEARING	1	1
6	CNA40557	DIN_3760-A40x55x7 STEFA	SHAFT SEAL	1	1
7	21096	NAPA HITS. JA KONEIST.	HUB	1	1
8	17249	HAMMASTETTU VANNASKIEKKO	COULTER DISC	1	1
9	A0C0T4524	6-KOLOR.UPP.M12X30 10.9 DIN799	SCREW	4	4
10	33217	LANN. VARS. OIK. HITS. KUMI	COULTER ARM, RIGHT	1	
	33207	LANN. VARS. VAS. HITS. KUMI	COULTER ARM, LEFT		1
11	31389	KUMIPRIKKA	WASHER	6	6
12	33213	PUTKI HITS. OIK. LANN.VANNAS	COULTER TUBE, RIGHT	1	
	33201	PUTKI HITS. VAS. LANN.VANNAS	COULTER TUBE, LEFT		1
13	31388	KARBIDIPALA	CARBIDE PIECE	1	1
14	B5A0V1524	KORILAATTA M10 DIN9021B ZN	WASHER	3	3
15	AGA113014	6-MUTTERI II M10 DIN985-8 ZN	NUT	3	3
	33218	LANN. VANNAS M KUMIP. OIK. KP	FERT COULTER, RUBBER RIGHT		
	33208	LANN. VANNAS M KUMIP. VAS. KP	FERT COULTER, RUBBER LEFT		

2.8RUNKO M, COMBI FRAME M, COMBI

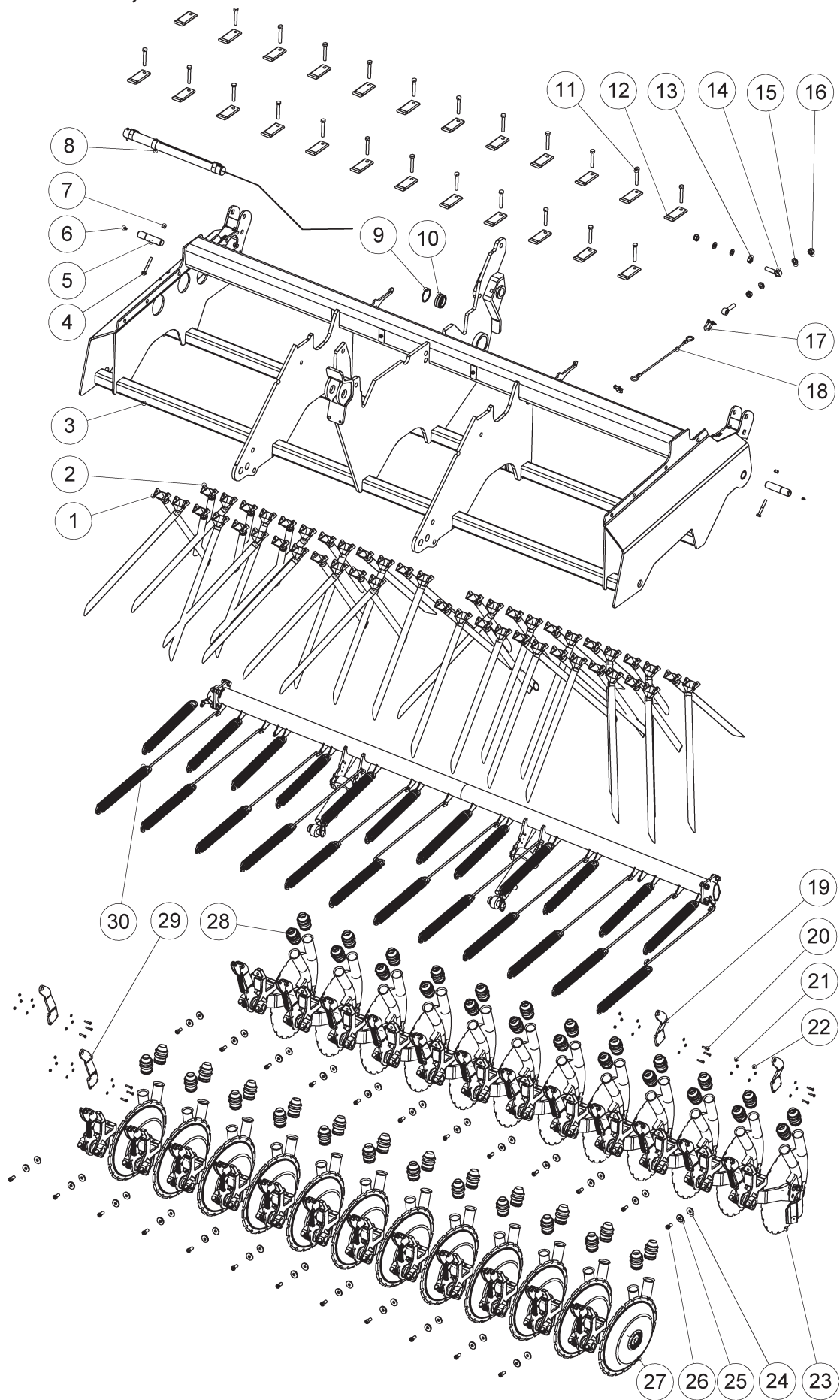

A GOOD WAY TO WORK HARD

OSA PART	KOODI CODE	NIMITYS	DESCRIPTION	M300 M400	
1	20878	SUPPILO SUORA+PUTKI PIT LP	FEEDER TUBE	6	8
	20877	SUPPILO SUORA+PUTKI LYH LP	FEEDER TUBE	5	7
	33150	LANN.SYÖTTÖPUTKI VINO L=750	FEEDER TUBE	4	2
	33534	SUPPILO VINO VAS+PUTKI 650	FEEDER TUBE	5	6
	20879	SUPPILO VINO+PUTKI LYH LP	FEEDER TUBE	1	3
	33482	LANN.SYÖTTÖPUTKI VINO L=750 VA	FEEDER TUBE	3	6
2	20607	SIEMENSYÖTTÖPUTKI KP	FEEDER TUBE	3	4
	20879	SUPPILO VINO+PUTKI LYH LP	FEEDER TUBE	3	3
	20605	SIEMENSYÖTTÖPUTKI KP	FEEDER TUBE	4	7
	20877	SUPPILO SUORA+PUTKI LYH LP	FEEDER TUBE	6	9
	33534	SUPPILO VINO VAS+PUTKI 650	FEEDER TUBE	3	4
	33576	SUPPILO VINO VAS+PUTKI 480	FEEDER TUBE	5	5
3	31616	RUNKO HITS. M300	FRAME	1	
	31980	M400 RUNKO HITS.	FRAME		1
4	A0A2F1514	6-RUUVI M10X75 8.8 DIN931 ZN	SCREW	2	2
5	17289	TAPPI RUNKON PÄÄTYYN	PIVOT	2	2
6	BJ6500000	RASVANIPPA M 8*1.25 N:O 507	GREASE NIPPLE	2	2
7	AGA113014	6-MUTTERI II M10 DIN985-8 ZN	NUT	2	2
8	33060	KESKUSSÄÄDÖN OSOITIN	CENTRAL ADJUSTMENT INDICA- TOR	1	1
9	BH2220021	SEGER-RENG REI 62X2 472	CIRCLIP	1	1
10	CEGE40	NIVELLAAKERI INA GE 40 DO	BEARING	1	1
11	A0C2L1514	6-RUUVI M12X80 8.8 DIN931 ZN	SCREW	24	32
12	17576	KIINNITIN	HOLDER	24	32
13	A51700	6-MUTTERI M16 DIN934-8 ZNK	NUT	2	2
14	A0G3A1014	SILMÄRUUVI DIN444 16x70	SCREW	2	2
15	B5G102524	ALUSLAATTA M16 DIN125A ZN	WASHER	4	4
16	AGG113014	6-MUTTERI II M16 DIN985-8 ZN	NUT	2	2
17	BC3000002	RUUVISAKKELI M8 ZN	SHACKLE	2	2
18	33288	VAIJERI 6mm L=470mm	WIRE ROPE	1	1
19	319431	ETUVANTAAN JOUSEN LISÄKIINNITI	SPRING HOLDER	2	2
20	A02807	6-RUUVI. M6X30 8.8 DIN 933 ZN	SCREW	12	12
21	AG6113014	6-MUTTERI II M 6 DIN985-8 ZN	NUT	12	12
22	B560E1524	ALUSLAATTA M 6 DIN125A ZN	WASHER	24	24
23	32521	2-PUTKINEN TAKAVANNAS M KP	REAR COULTER, 2 -TUBES	12	16
24	22231	RIKKA 13/35-5 DIN6340	WASHER	24	32
25	210724000	ALUSLEVY 4*35/12.2	WASHER	24	32
26	A0C0S4524	6-KOLOR.M12X25 8.8 DIN912 ZN	SCREW	24	32
27	32658	2-PUTKINEN ETUVANNAS M KP	FRONT COULTER, 2-TUBES	12	16
28	32485	MULTASUOJA KELTAINEN	DUST SHIELD	48	64
29	319401	TAKAVANTAAN JOUSEN LISÄKIINNIT	SPRING HOLDER	2	2
30	31930	M300 KESKUSSÄÄTÖ	CENTRAL ADJUSTMENT	1	

2.9 SIEMENVANNAS M
SEED COULTER M

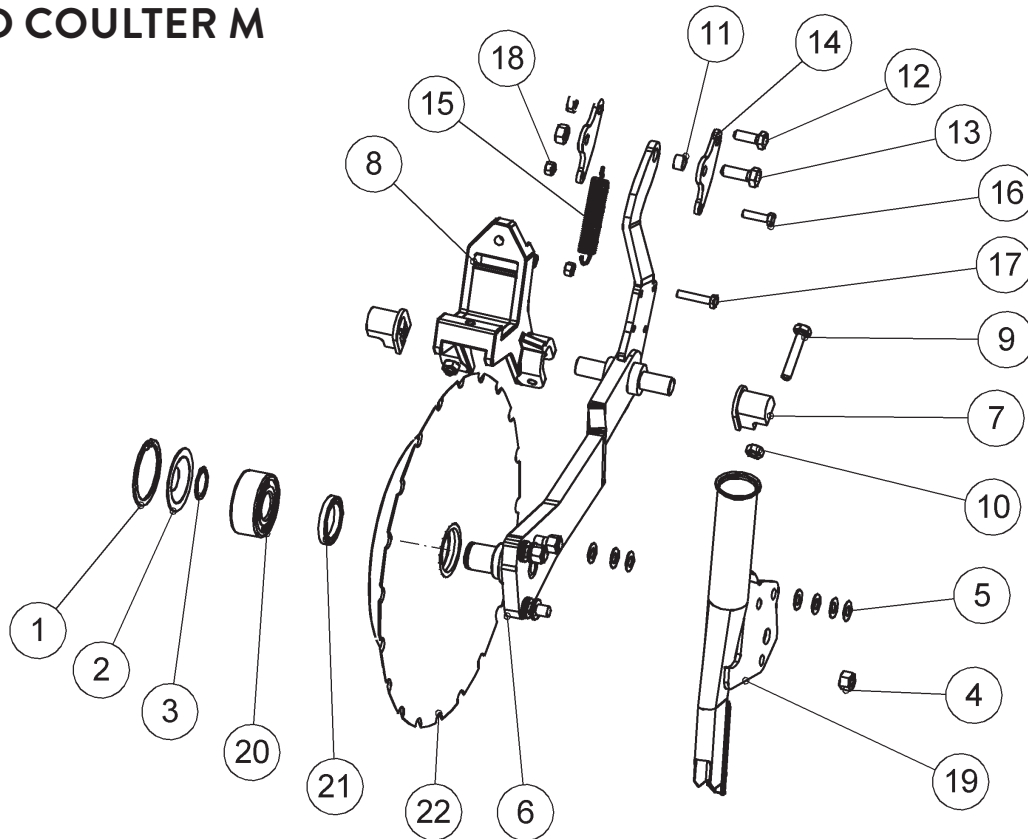

OSA PART	KOODI CODE	NIMITYS	DESCRIPTION	ETU/ TAKA/ FRONT REAR	
				FRONT	REAR
1	BH2C21L14	SEGER-RENG REI 72X2.5 472	CIRCLIP	1	1
2	21095	SUOJALEVY	COVER PLATE	1	1
3	BH1011L11	SEGER-RENG AKS 30X1.5 471	CIRCLIP	1	1
4	AGC113014	6-MUTTERI II M12 Din985-8 Zn	NUT	4	4
5	B61473	LAUTASJOUSI Ø23/Ø12.2*1	SPRING	21	21
6	36641	VARSII HITS	COULTER ARM, FRONT	1	
	36652	VARSII HITS TAKA	COULTER ARM, REAR		1
7	17162	MUOVILAAKERI VANTAASEEN	PLASTIC BEARING	2	2
8	17118	VANTAAN KIINNITIN	COULTER HOLDER	1	1
9	AOA201014	6-RUUVI M10X60 8.8 Din931 Zn	SCREW	2	2
10	AGA113014	6-MUTTERI II M10 Din985-8 Zn	NUT	3	3
11	31942	HOLKKI	BUSHING	1	1
12	AOA101524	6-RUUVI M10X30 8.8 Din933 Zn	SCREW	1	1
13	AOC151514	6-RUUVI M12X35 8.8 Din933 Zn	SCREW	1	1
14	31941	KEINU PIKKUJOUSELLE	SPRING SWING	2	2
15	32401	VETOJOUSI 2.5*19.3*108 Sink920	SPRING	1	1
16	A08101514	6-RUUVI M8X30 8.8 Din933 Znc	SCREW	1	1
17	A081A1514	6-RUUVI M8X40 8.8 Din 933 Zn	SCREW	1	1
18	A50710	6-MUTTERI II M8 A2 Din985 Aisi	NUT	3	3
19	36623	PUTKI HITS. ETU 1-PUT.	COULTER 1-TUBE	1	
	36634	PUTKI HITS. TAKA 1-PUT.	COULTER 1-TUBE		1
	36643	PUTKI HITS. ETU 2-PUT.	COULTER 2-TUBE	1	
	36657	PUTKI HITS. TAKA 2-PUT.	COULTER 2-TUBE		1
20	CE33062RSSKF	2-RIV. VIISTOKUULALAAK. 33062R	BEARING	1	1
21	CNA40557	DIN_3760-A40x55x7 STEFA	SHAFT SEAL	1	1
22	21182	VANNAS HITS. JA KONEIST.	COULTER DISC	1	1
	V20670	SIEMENVANNAS M, KP	COULTER DISC		
	36670	SIEMENVANN. M, ETU, 1- PUT. KP	SEED COULTER, FRONT 1-TUBE		
	36640	SIEMENVANN. M, ETU, 2- PUT. KP	SEED COULTER, FRONT 2-TUBE		
	36660	SIEMENVANN. M, TAKA, 1- PUT. KP	SEED COULTER, REAR 1-TUBE		
	36650	SIEMENVANN. M, TAKA, 2- PUT. KP	SEED COULTER, REAR 2-TUBE		

2.10 VANNASPAINATUKSEN KESKUSSÄÄTÖ M CENTRAL ADJUSTMENT OF THE COULTER PRESSURE M

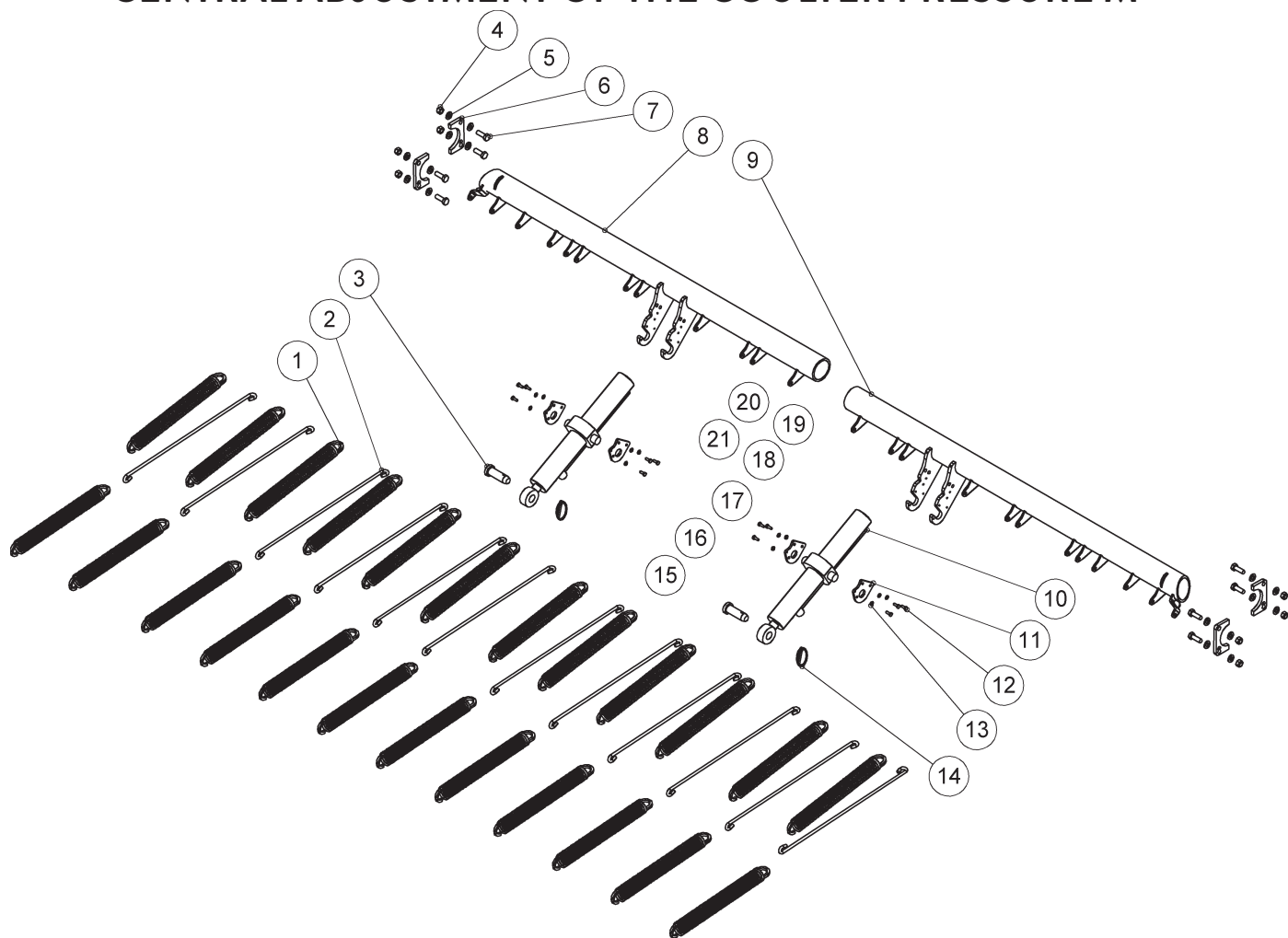

OSA PART	KOODI CODE	NIMITYS	DESCRIPTION	M300	M400
1	31931	VETOJOUSI 7x45x400	TENSION SPRING	25	32
2	31898	TANKO ETUVANTAALLE	BAR FOR FRONT COULTER	12	16
3	D14446	SYLINTERIN TAPPI 14446	PIVOT FOR CYLINDER	2	2
4	AGC113014	6-MUTTERI II M12 DIN985-8 ZN	NUT	8	8
5	B5C0R2024	ALUSLAATTA M12 DIN125A ZN	WASHER	16	16
6	31892	PUTKENPAIKOITIN	HOLDER	4	4
7	A0C151514	6-RUUVI M12X35 8.8 DIN933 ZN	SCREW	8	8
8	31896	M300 KESKUSSÄÄDÖN PUTKI OIKEA	BAR	1	
	31985	HITS	BAR		1
9	31890	M3 KESKUSSÄÄDÖN PUTKI VAS HITS.	BAR	1	
	31983	M4	BAR		1
10	31554	KESKUSSÄÄDÖN SYLINTERI	CYLINDER	2	2
11	318931	SYLINTERIN LUKITUSPALA	LOCK PIECE FOR CYLINDER	4	4
12	A060G1024	6-RUUVI M6X16 8.8 DIN 933 ZN	SCREW	12	12
13	B560E1524	ALUSLAATTA M 6 DIN125A ZN	WASHER	12	12
14	BE6000002	RENGAS-SOKKA 6X40 L=40 ZN	LINCHPIN	2	2
15	133300P	USIT-TIIVISTE 217-06 3/8	SAEL	8	8
16	133472P	BANJO BSPP 3/8/3/8	BANJO CONNECTOR	4	4
17	133056P	BANJORUUVI R 3/8 181-06	BANJO SCREW	4	4
18	32801	LET 1/4 1500R3/8SR1/4S	HOSE	4	4
19	134705P	T-NIPPA 702-04 1/4	T-NIPPLE	2	2

2.11 RUNKO D FRAME D

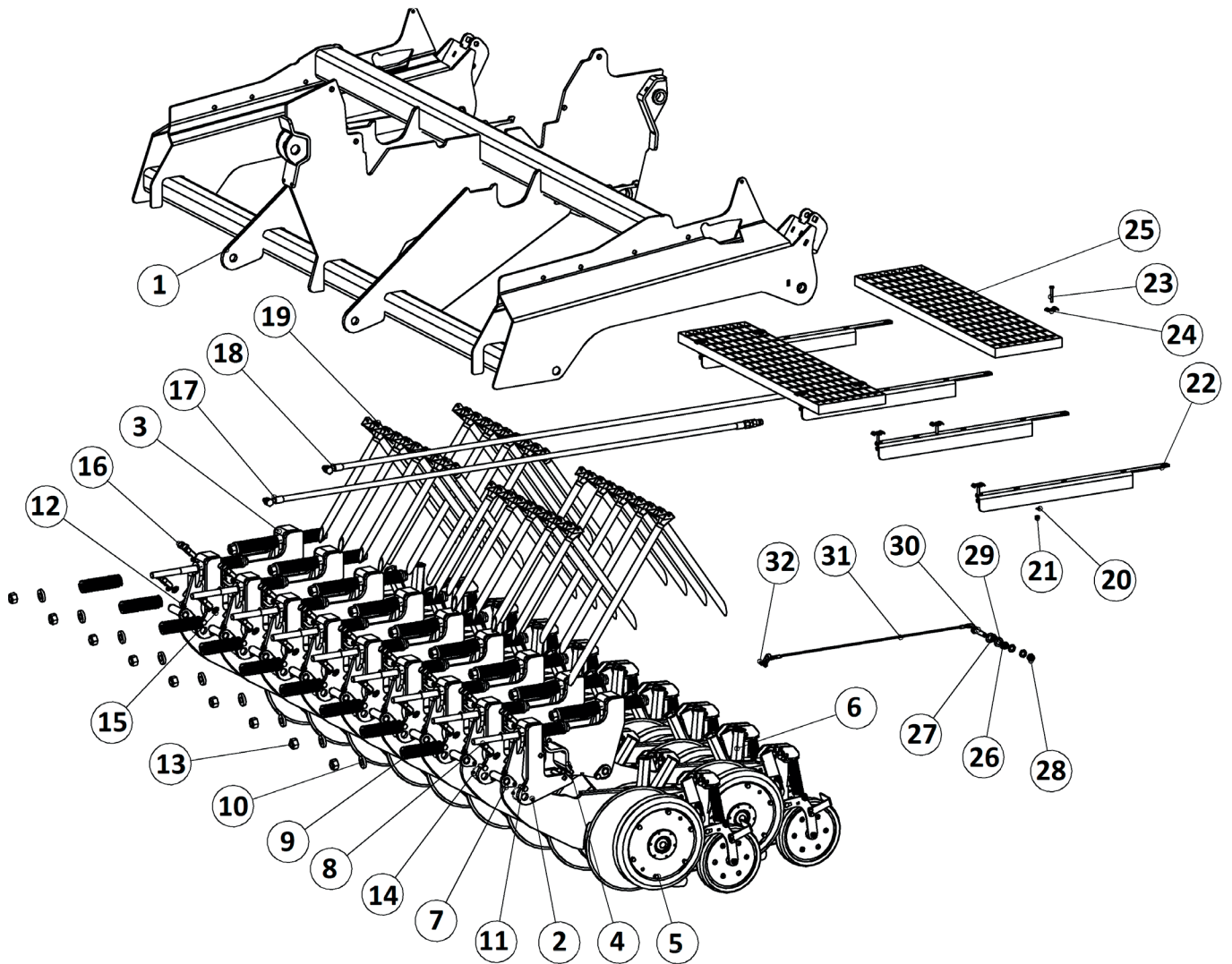

A GOOD WAY TO WORK HARD

OSA PART	KOODI CODE	NIMITYS	DESCRIPTION	D300	D400
1	33810	RUNKO D300 HITSATTU M17	FRAME	1	
	33876	RUNKO D400 HITSATTU M17	FRAME		1
2	33820	ETUVANTAAN KIINNITIN D	COULTER HOLDER	9	12
3	33825	TAKAVANTAAN KIINNITIN D	COULTER HOLDER	9	12
4	33881	VANTAAN KIINNITTIMEN VASTE D	HOLDER STOPPER	18	24
5	35370	VANNAS KOOTTU DIRECT M17	COULTER	18	24
6	35491	VANNASPUTKET D	COULTER TUBES	18	24
7	33883	VANTAAN KIIN.TAPPI HITS	COULTER HOLDER	18	24
8	31757	6-RUUVI M24X420 DIN 931	SCREW	18	24
9	31734	TYÖKALUJOUSI 25*50*178	SPRING	36	48
10	B5R1F4025	ALUSLEVY M24 DIN_7349-25	WASHER	36	48
11	A0C1A1014	6-RUUVI M12X40 8.8 Din933 Zn	SCREW	18	24
12	AGC113014	6-MUTTERI II M12 Din985-8 Zn	NUT	18	24
13	AGR113014	6-MUTTERI II M24 Din985 Zn	NUT	18	24
14	BJ6150400	RASVANIPPA M6*1/Suora N 504	GREASE NIPPLE	18	24
15	B5G102524	ALUSLAATTA M16 Din125A Zn	WASHER	74	96
16	A0G201514	6-RUUVI M16X60 8.8 Din931 Zn	SCREW	72	96
17	33667	HYDRAULILETKU TAKIMM. 2225	HOSE	1	1
18	33668	HYDRAULILETKU ETUMM. 2225	HOSE	1	1
19	20604	SIEMENSYÖTTÖPUTKET	FEEDER TUBE	36	48
20	B580H1624	ALUSLAATTA M 8 Din125A Zn	WASHER	8	8
21	AG8113014	6-MUTTERI II M 8 Din985-8 Zn	NUT	8	8
22	36122	KULMALEVY ASTINTASOON	BRACKET	4	4
23	A05960	6-RUUVI M8X60 8.8 Din 931 Zn	SCREW	8	8
24	31175	KIINNIKE	FASTENER	8	8
25	36118	TASORITILÄ KAPEA SMD300	GRILL	2	
	36123	TASORITILÄ KAPEA D400	GRILL		2
26	A51700	6-MUTTERI M16 Din934-8 Znk	NUT	1	1
27	35459	SULKIJAPYÖRÄN HOLKKI	BUSHING	1	1
28	AGG113014	6-MUTTERI II M16 Din985-8 Zn	NUT	1	1
29	B5L173024	ALUSLAATTA M20 Din125A Zn	WASHER	2	2
30	A0G2L1524	6-RUUVI M16X80 8.8 Din933Znc	SCREW	1	1
31	33721	VAIJERI 6mm L=960	WIRE ROPE	1	1
32	BC3000002	RUUVISAKKELI M8 Zn	SHACKLE	1	1

2.11.1 VANNAS D
COULTER D

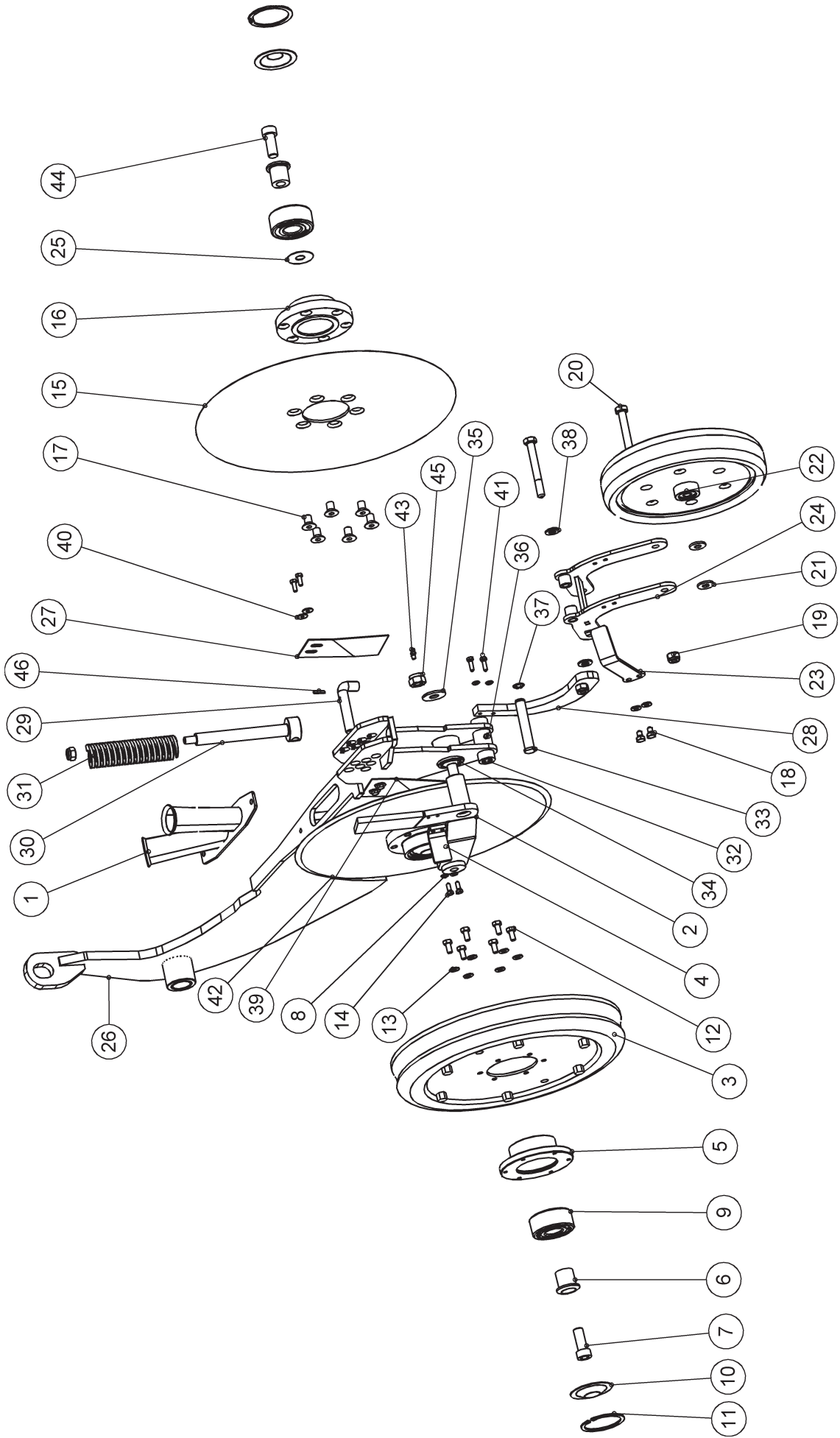

A GOOD WAY TO WORK HARD

OSA PART	KOODI CODE	NIMITYS	DESCRIPTION	KPL/ PCS
1	35491	VANNASPUTKET D		1
2	35441	KANNATINPYÖRÄN VARS	ARM FOR HOLDER WHEEL	1
3	35356	PYÖRÄ 400*55	WHEEL	1
4	35455	KANNATINPYÖRÄN RAAPIJA	SCRAPER	1
5	35456	LAAKERIHOLKKI KANNATINPYÖRÄÄN	BUSHING	1
6	35362	LAAKERIN KIINNITYSHOLKKI	BUSHING	3
7	35463	6-KOLOR. M16x40 VAS.KÄT.	SCREW	2
8	B560E1524	ALUSLAATTA M 6 Din125A Zn	WASHER	4
9	CE33062RSSKF	2-RIV. VIISTOKUULALAAK. 33062R	BEARING	3
10	21095	SUOJALEVY	COVER PLATE	3
11	BH2C21L14	SEGER-RENG REI. 72X2.5 472	CIRCLIP	3
12	A080G1514	6-RUUVI M8X16 8.8 Din 933 Zn	SCREW	6
13	B580H1624	ALUSLAATTA M 8 Din125A Zn	WASHER	8
14	A060G1024	6-RUUVI M6X16 8.8 Din 933 Zn	SCREW	6
15	35387	KIEKKO DIRECT	COULTER DISC	2
16	35386	D KIEKON NAPA M17	HUB	1
17	A0C1T4524	6-KOLOR.UPP.M12X20 10.9 Din799	SCREW	12
18	A080C1522	6-RUUVI M8X12 8.8 Din 933 Zn	SCREW	2
19	AGC113014	6-MUTTERI II M12 Din985-8 Zn	NUT	3
20	A0C3A1014	6-RUUVI M12X100 8.8 Din931Zn	SCREW	2
21	131328000	VÄLILEVY VANT LAAKEROINTIIN	PLATE	2
22	10183	JYRÄPYÖRÄ KP	WHEEL	1
23	35454	SULKIJAPYÖRÄN RAAPIJA	SCRAPER	1
24	35309	SULKIJAPYÖRÄN VARS	ARM FOR CLOSER WHEEL	1
25	35353	SOVITELEVY 16/45	PLATE	2
26	35380	D VANNASRUNKO M17	FRAME	1
27	35451	JOUSITERÄS RAAPIJA OIKEA	SCRAPER	1
28	35337	MUOVIKIELEKE VANTAAN SISÄÄN	PLASTIC PROJECTION	1
29	35383	RAJOITINTAPPI	PIVOT	1
30	35446	JOUSEN KESKITAPPI	PIVOT	1
31	35445	TYÖKALUJOUSI 20*40*152	SPRING	1
32	WB802161820	WB802 LAAKERI 16/18-20	BEARING	2
33	31774	SARANATAPPI	PIVOT	1
34	CV0303420	DYMET LAAKERI 30/34-20	BEARING	2
35	35449	16/40 RIKKA	WASHER	1
36	BJ6150400	RASVANIPPA M6*1/Suora N 504	GREASE NIPPLE	1
37	BH0H11L16	SEGER-RENG AKS 16X1 471	CIRCLIP	1
38	B5C0R2024	ALUSLAATTA M12 Din125A Zn	WASHER	2
39	35452	JOUSITERÄS RAAPIJA VASEN	SCRAPER	1
40	B560N1524	KORILAATTA M 6 Din9021 Zn	WASHER	4
41	A060L1524	6-RUUVI M6X20 8.8 Din 933 Zn	SCREW	2
42	35462	KIEKKO KOOTTU	DISC	2
43	BJ6157400	RASVANIPPA M 6*1/45 Ast.N574	GREASE NIPPLE	1
44	35465	6-KOLOR. M16x40	SCREW	1
45	AGG113014	6-MUTTERI II M16 Din985-8 Zn	NUT	1
46	B840L0001	JOUSISOKKA 4X20 Din1481 Znc	SPLIT PIN	1

2.12 VETOLAITE S DRAWBAR S

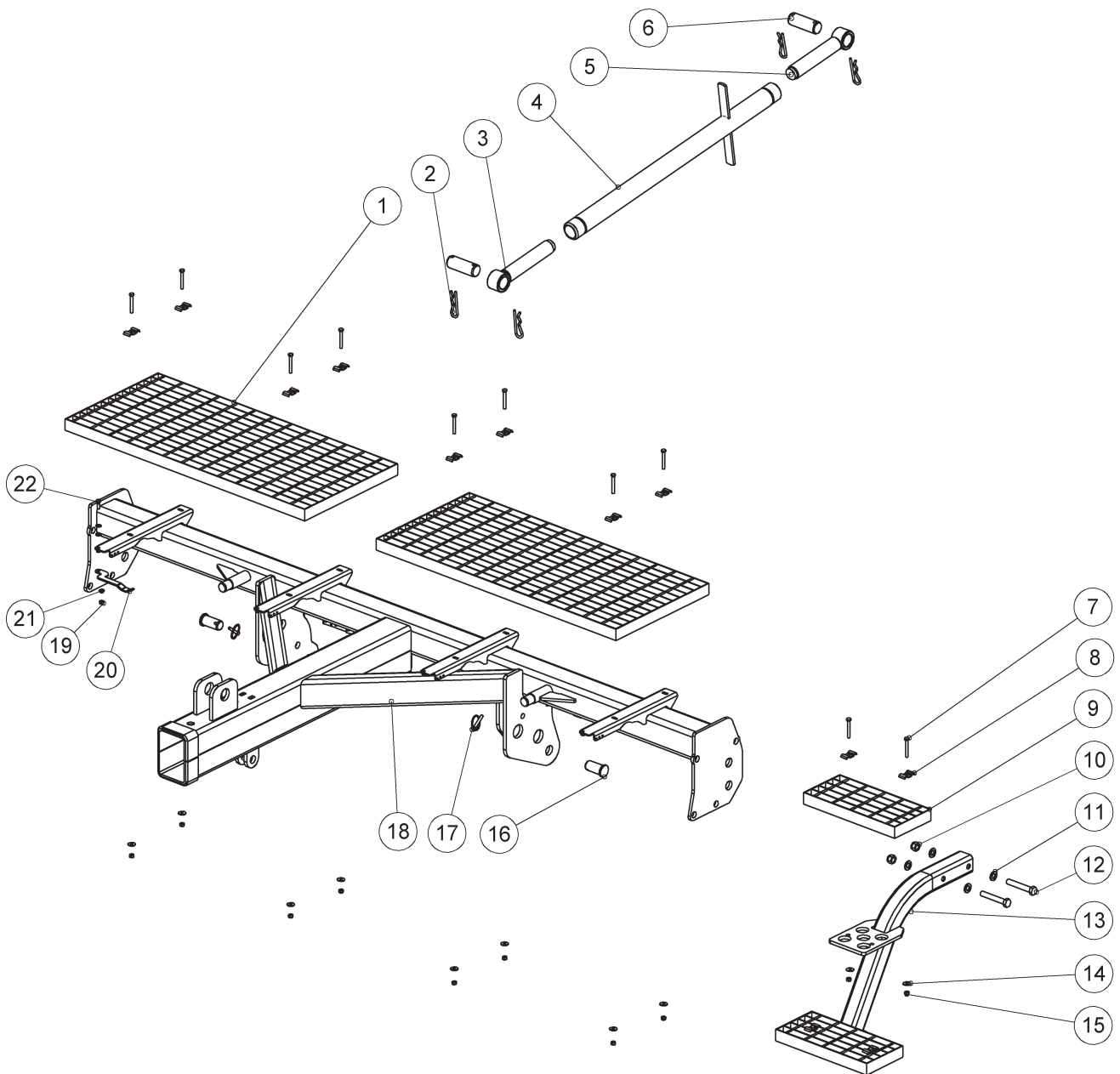

A GOOD WAY TO WORK HARD

OSA PART	KOODI CODE	NIMITYS	DESCRIPTION	S300	S400
1	31705	TASORITILÄ ETEEN	GRILL	2	
	32429	TASORITILÄ 400	GRILL		2
2	BD0117	NEULASOKKA 6M _m DIN11024 ZN	COTTER PIN	4	4
3	17666	KIERREKLUNSSI VASENK. HITS.	THREAD PIECE	1	1
4	31643	VÄLIPUTKI HITS. S300 S400	BAR	1	1
5	17665	KIERREKLUNSSI OIK. HITS.	THREAD PIECE	1	1
6	17347	TAPPI SYLINT. JA TYÖNTÖV.	PIVOT	2	2
7	A05960	6-RUUVI M8X60 8.8 DIN 931 ZN	SCREW	12	12
8	31175	KIINNIKE	HOLDER	12	12
9	32519	TASORITILÄ L=382	GRILL	2	2
10	AGG113014	6-MUTTERI II M16 DIN985-8 ZN	NUT	2	2
11	B5G102524	ALUSLAATTA M16 DIN125A ZN	WASHER	4	4
12	A0G3A1512	6-RUUVI M16X100 8.8 DIN931ZN	SCREW	2	2
13	32594	ASTIN HITS ETEEN	STEP	1	1
14	B580N1524	KORILAATTA M 8 DIN9021B ZN	WASHER	12	12
15	AG8113014	6-MUTTERI II M 8 DIN985-8 ZN	NUT	12	12
16	17558	KIINNITYSTAPPI VETOLAITTEELLE	PIVOT	2	2
17	BE8600002	RENGAS-SOKKA 8X45 L=040 ZN	LINCHPIN	2	2
18	31571	VETORUNKO HITS.	DRAW-FRAME	1	
	32625	VETORUNKO 4000 S HITS.	DRAW-FRAME		1
19	AG8113014	6-MUTTERI II M 8 Din985-8 Zn	NUT	1	1
20	35716	KIERTOKOEPUNTARIN TELINE	HOLDER	1	1
21	B580N1524	KORILAATTA M 8 Din9021B Zn	WASHER	3	3
22	A080S1514	6-RUUVI M8X25 8.8 Din933 Zn	SCREW	1	1

2.13 VETOLAITE SMD DRAWBAR SMD

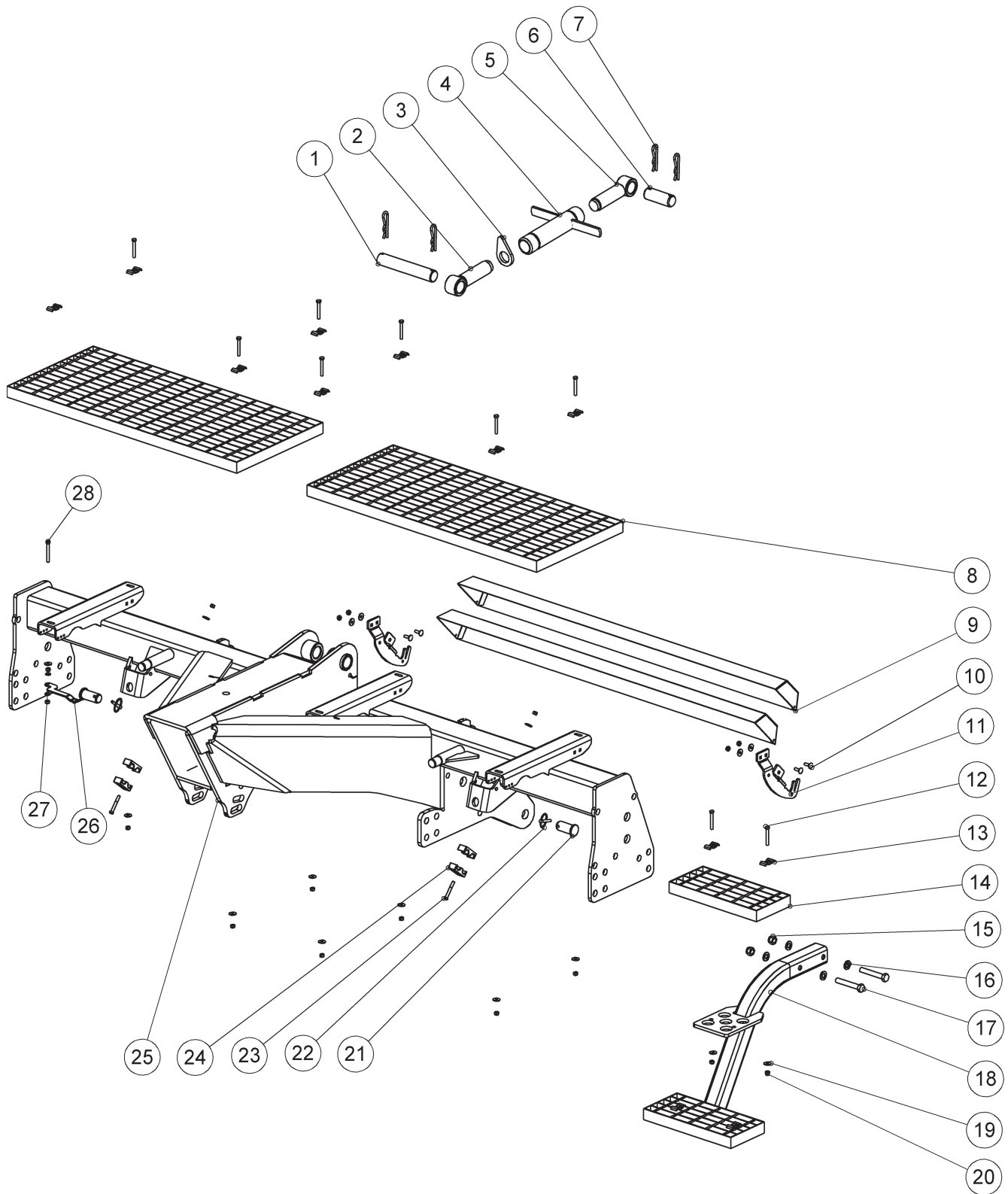

A GOOD WAY TO WORK HARD

OSA part	KOODI CODE	NIMITYS	DESCRIPTION	SMD300 SMD400	
1	20803	TYÖNTÖVARRENTAPPI	PIVOT FOR PUSHARM	1	1
2	31722	KIERREKLUNSSI VASENK. HITS.	THREAD PIECE	1	1
3	33275	TYÖNTÖVARREN LUKITSIN M D	LOCK FOR PUSHARM	1	1
4	31718	TYÖNTÖVARREN PUTKI HITS.	PUSHBAR	1	1
5	31720	KIERREKLUNSSI OIK. HITS.	THREAD PIECE	1	1
6	17347	TAPPI SYLINT. JA TYÖNTÖV.	PIVOT	1	1
7	BD0117	NEULASOKKA 6Mm DIN11024 ZN	COTTER PIN	4	4
8	31705	TASORITILÄ ETEEN	GRILL	2	
	32429	TASORITILÄ 400	GRILL		2
9	17663	KIERTOKOEKAUKALO	CALIBRATION TRAY	2	
	18202	KIERTOKOEKAUKALO 400 HITS.	CALIBRATION TRAY		2
10	A080S3014	LUKKOR. M8X25 4.6 DIN 603 ZN	SCREW	4	4
11	33337	KK-KAUKALON KANNAKE	CALIBRATION TRAY HOLDER	2	2
12	A05960	6-RUUVI M8X60 8.8 DIN 931 ZN	SCREW	12	12
13	31175	KIINNIKE	HOLDER	12	12
14	32519	TASORITILÄ L=382	GRILL	2	2
15	AGG113014	6-MUTTERI II M16 DIN985-8 ZN	NUT	2	2
16	B5G102524	ALUSLAATTA M16 DIN125A ZN	WASHER	4	4
17	A0G3A1512	6-RUUVI M16X100 8.8 DIN931ZN	SCREW	2	2
18	32594	ASTIN HITS ETEEN	STEP	1	1
19	B580N1524	KORILAATTA M 8 DIN9021B ZN	WASHER	18	18
20	AG8113014	6-MUTTERI II M 8 DIN985-8 ZN	NUT	18	18
21	17558	KIINNITYSTAPPI VETOLAITTEELLE	PIVOT	2	2
22	BE8600002	RENGAS-SOKKA 8X45 L=040 ZN	LINCHPIN	2	2
23	A05951	6-KOLOR. M8X60 8.8 DIN 912 ZN	SCREW	2	2
24	D6C322	KAKSOISKIINNIKE CF 322-22	HOLDER	4	4
25	32600	VETOLAITE MD300 HITS. 2014	DRAW BAR	1	
	32620	VETOLAITE MD400 HITS. 2014	DRAW BAR		1
26	35716	KIERTOKOEPUUNTARIN TELINE	HOLDER	1	1
27	B580H1624	ALUSLAATTA M 8 Din125A Zn	WASHER	2	2
28	A082A1024	6-RUUVI M8X70 8.8 Din 933 Zn	SCREW	1	1

3. JYRÄPYÖRÄSTÖ WHEEL SET

3.1 JYRÄPYÖRÄSTÖN RUNKO SMD FRAME OF THE WHEEL SET SMD

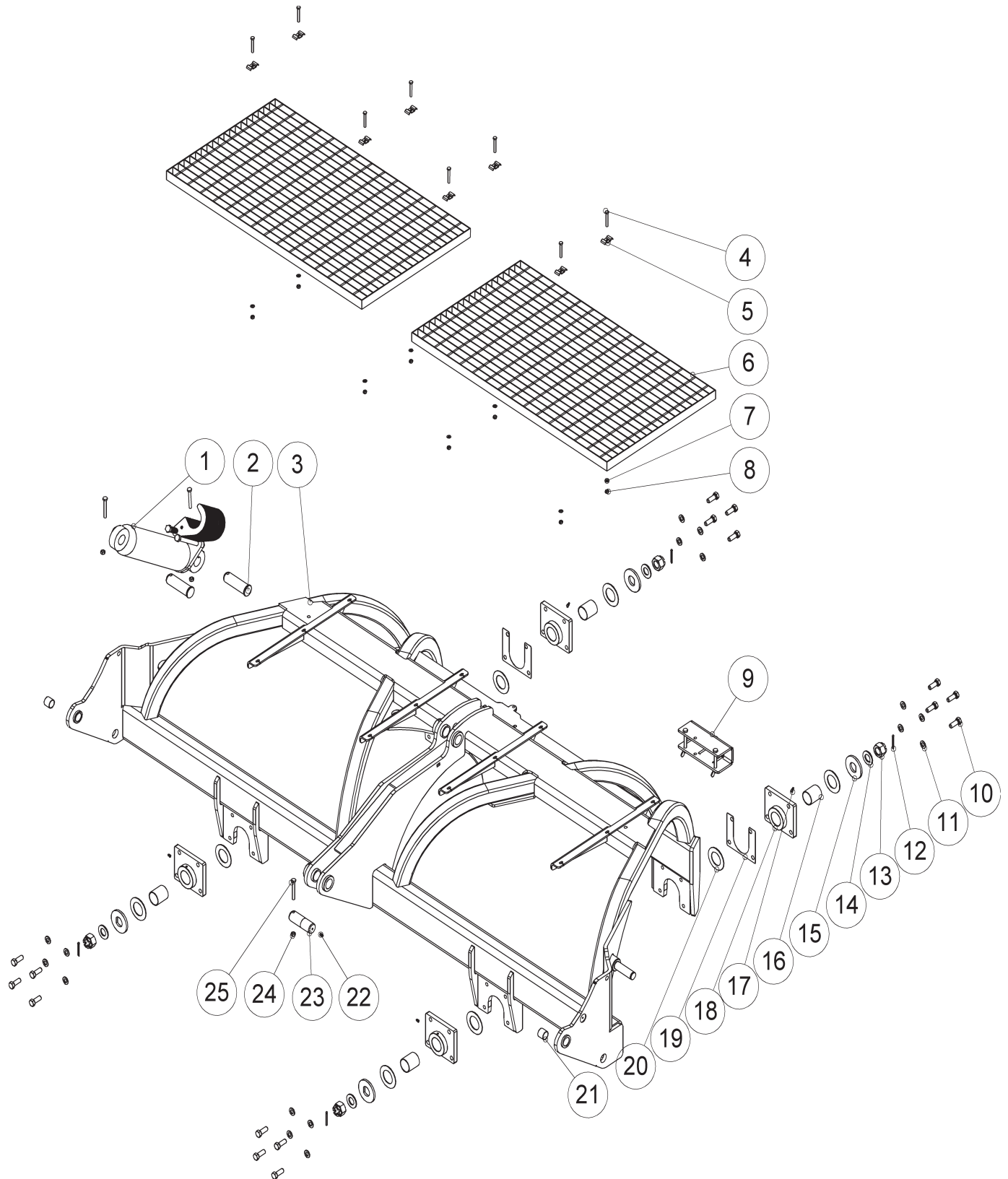

A GOOD WAY TO WORK HARD

OSA PART	KOODI CODE	NIMITYS	DESCRIPTION	SMD300	SMD400
1	17867	SYLINTERI KOOTTU	CYLINDER	1	1
2	17667	TAPPI TYÖNTÖVARRELLE	PIVOT	2	2
3	32530	JYRÄPYÖRÄSTÖN RUNKO HITS. 300	FRAME	1	
	33430	JYRÄPYÖRÄSTÖN RUNKO HITS. 400	FRAME		1
4	A05960	6-RUUVI M8X60 8.8 DIN 931 ZN	SCREW	8	8
5	31175	KIINNIKE	HOLDER	8	8
6	31542	TASORITILÄ	GRILL	2	
	32409	TASORITILÄ 400	GRILL		2
7	B580H1624	ALUSLAATTA M 8 DIN125A ZN	WASHER	8	8
8	AG8113014	6-MUTTERI II M 8 DIN985-8 ZN	NUT	8	8
9	18242	HUOLTOTUKI KOOTTU	MAINTENANCE SUP- PORT	1	1
10	A0G1F1514	6-RUUVI M16X45 8.8 DIN933 ZN	SCREW	16	16
11	B5G102524	ALUSLAATTA M16 DIN125A ZN	WASHER	16	16
12	BA51L0004	SAKSISOKKA 5X50 DIN94 ZN	SPLIT PIN	4	4
13	33442	KUUSIOKRUUNUMUTTERI M30x1.5 DI	NUT	4	4
14	B61850	ALUSLAATTA M30 DIN125A ZNC	WASHER	4	4
15	33453	PYÖRIMISENESTO LEVY	SPINNING BLOCK PLATE	4	4
16	CV03L5060	DYMET LAAK REI'ITETTY 50/55/60	BEARING	4	4
17	BJ6157400	RASVANIPPA M 6*1/45 AST.N574	GREASE NIPPLE	4	4
18	33444	KEINUN LAAKERI KP	BEARING	4	4
19	33439	LAAKERIPESÄN SOVITUSLEVY	FITTING PLATE	2	2
20	31167	DRYMET PAINELAAKERI 92/55-2,5	BEARING	8	8
21	CV0303430	DYMET LAAKERI 30/34/30	BEARING	2	2
22	BJ6500000	RASVANIPPA M 8*1.25 N:O 507	GREASE NIPPLE	1	1
23	17339	TAPPI RUNKOON JYRÄPYÖRÄSTÖLLE	PIVOT	1	1
24	AGA113014	6-MUTTERI II M10 DIN985-8 ZN	NUT	3	3
25	A0A2F1514	6-RUUVI M10X75 8.8 DIN931 ZN	SCREW	3	3

3.2JYRÄPYÖRÄSTÖN KEINU SMD ROCKER SHAFT OF THE WHEEL SET SMD

SMD300

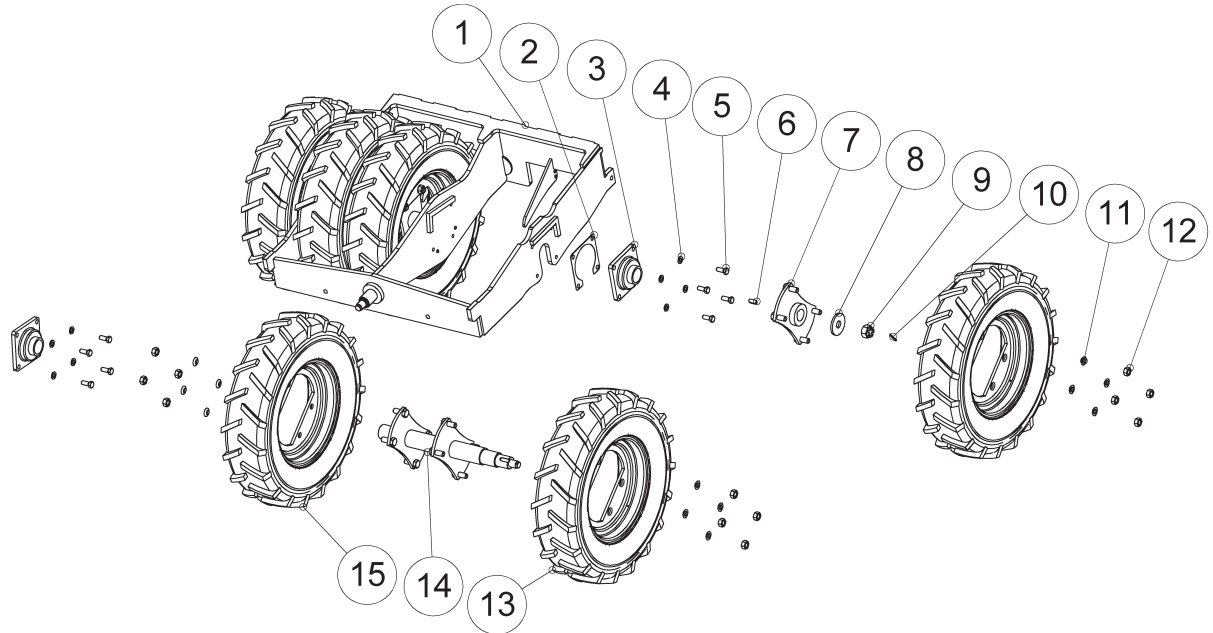

SMD400

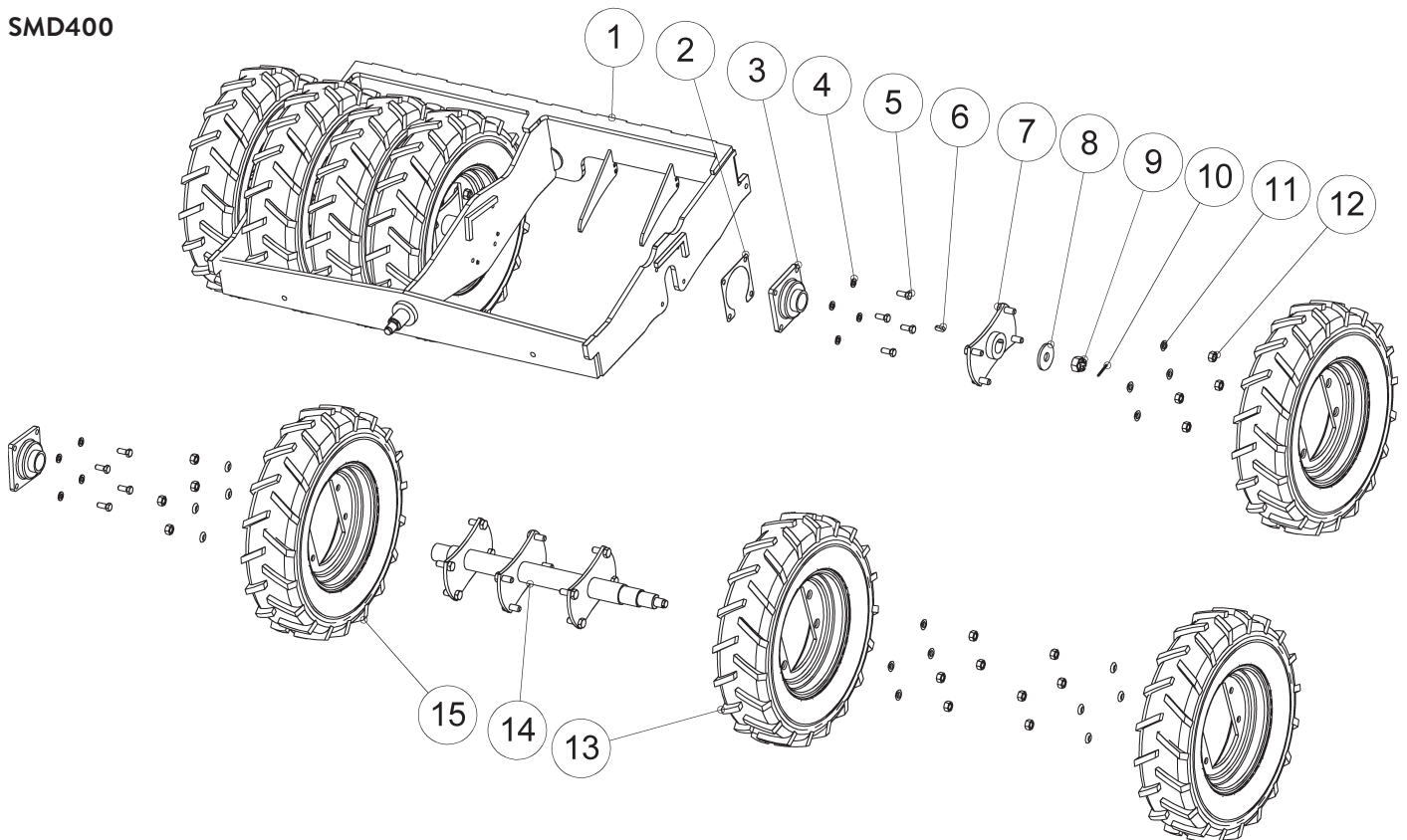

A GOOD WAY TO WORK HARD

OSA PART	KOODI CODE	NIMITYS	DESCRIPTION	SMD300	SMD400
1	33385	TELIKEHIKKO 300	FRAME	1	
	33310	TELIKEHIKKO 400	FRAME		1
2	33438	LAIPPALAAKERIN SOVITUSLEVY	FITTING PLATE	2	2
3	33387	LAIPPALAAKERI FK UCF 212	BEARING	4	4
4	B5G102524	ALUSLAATTA M16 DIN125A ZN	WASHER	16	16
5	A0G1A1514	6-RUUVI M16X40 8.8 DIN933 ZN	SCREW	16	16
6	773521	KIILA SYÖTTÖRULL.AKS.9*14*36	COTTER	2	2
7	32701	PYÖRÄNNAPA HITS	HUB	2	2
8	33443	ALUSLEVY 92/31/8	WASHER	2	2
9	33442	KUUSIOKRUUNUMUTTERI M30x1.5 DINUT		2	2
10	BA51L0004	SAKSISOKKA 5X50 DIN94 ZN	SPLIT PIN	2	2
11	A0L1F1216	KARTIOALUSLEVY M20 DIN6319-C	WASHER	24	32
12	A51900	6-MUTTERI M20X1.5 DIN934-8 ZN	NUT	24	32
13	33411	PYÖRÄ VASEN 16"	WHEEL	6	8
	33412	PYÖRÄ VASEN 20"	WHEEL	6	8
14	32699	PYÖRÄN AKSELI HITS. 300	SHAFT	2	
	33305	PYÖRÄSTÖN AKSELI 400	SHAFT		2
15	33311	PYÖRÄ OIKEA 16"	WHEEL	6	8
	33312	PYÖRÄ OIKEA 20"	WHEEL	6	8

3.3JYRÄPYÖRÄSTÖN SYLINTERI JA HUOLTOTUKI CYLINDER AND MAINTENANCE SUPPORT OF THE WHEEL SET

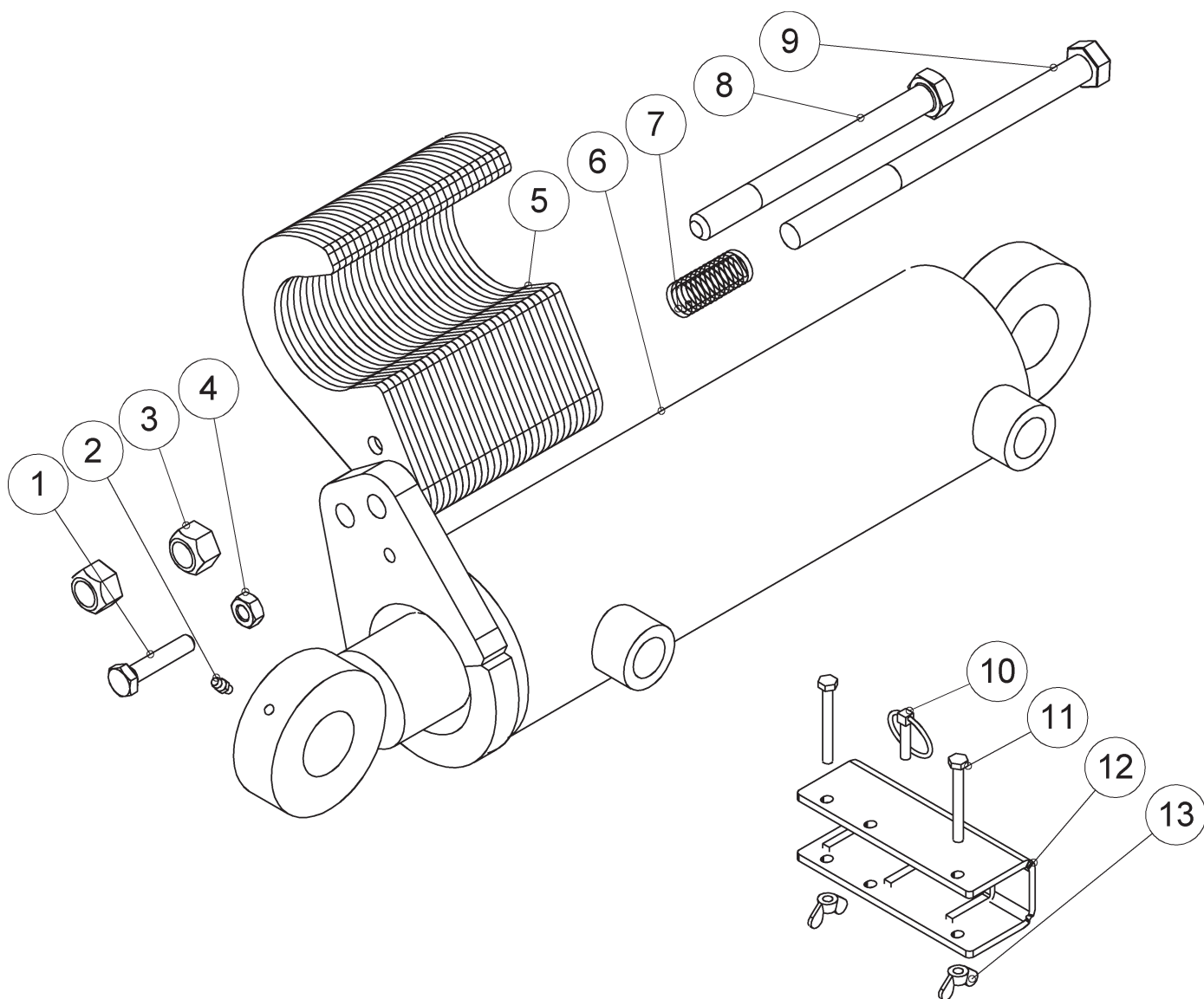

A GOOD WAY TO WORK HARD

OSA PART	KOODI CODE	NIMITYS	DESCRIPTION	SYLINTERI/ CYLINDER	HUOLTOTUKI/ SERVICE STAND
1	A0A1L1014	6-RUUVI M10X50 8.8 DIN933 ZN	SCREW	1	
2	BJ6150400	RASVANIPPA M6*1/SUORA N 504	GREASE NIPPLE	2	
3	AGG113014	6-MUTTERI II M16 DIN985-8 ZN	NUT	2	
4	AGA111014	6-MUTTERI M10 DIN934-8 ZN	NUT	1	
5	17411	LAMELLILEVY 5mm	LAMELLA PLATE	28	
6	17366	SYLINTERI HITS.	CYLINDER	1	
7	E46204	PURISTUSJOUSI 6204 75*23,6*3,6	SPRING	1	
8	A0G701514	6-RUUVI M16X180 8.8 DIN931 ZN	SCREW	1	
9	A0G6L1034	6-RUUVI M16X230 8.8 DIN931 ZN	SCREW	1	
10	BEC000002	RENGAS-SOKKA 10X40 L=40 ZN	LINCHPIN		1
11	A0A301314	6-RUUVI M10X90 8.8 DIN931 ZN	SCREW		2
12	18241	HUOLTOTUKI	MAINTENANCE SUP- PORT		1
13	AGA11J014	SIIPIMUTTERI M10 DIN315 ZN	NUT		2

3.4 JÄLKIHIRA SMD
FOLLOWING HARROW SMD

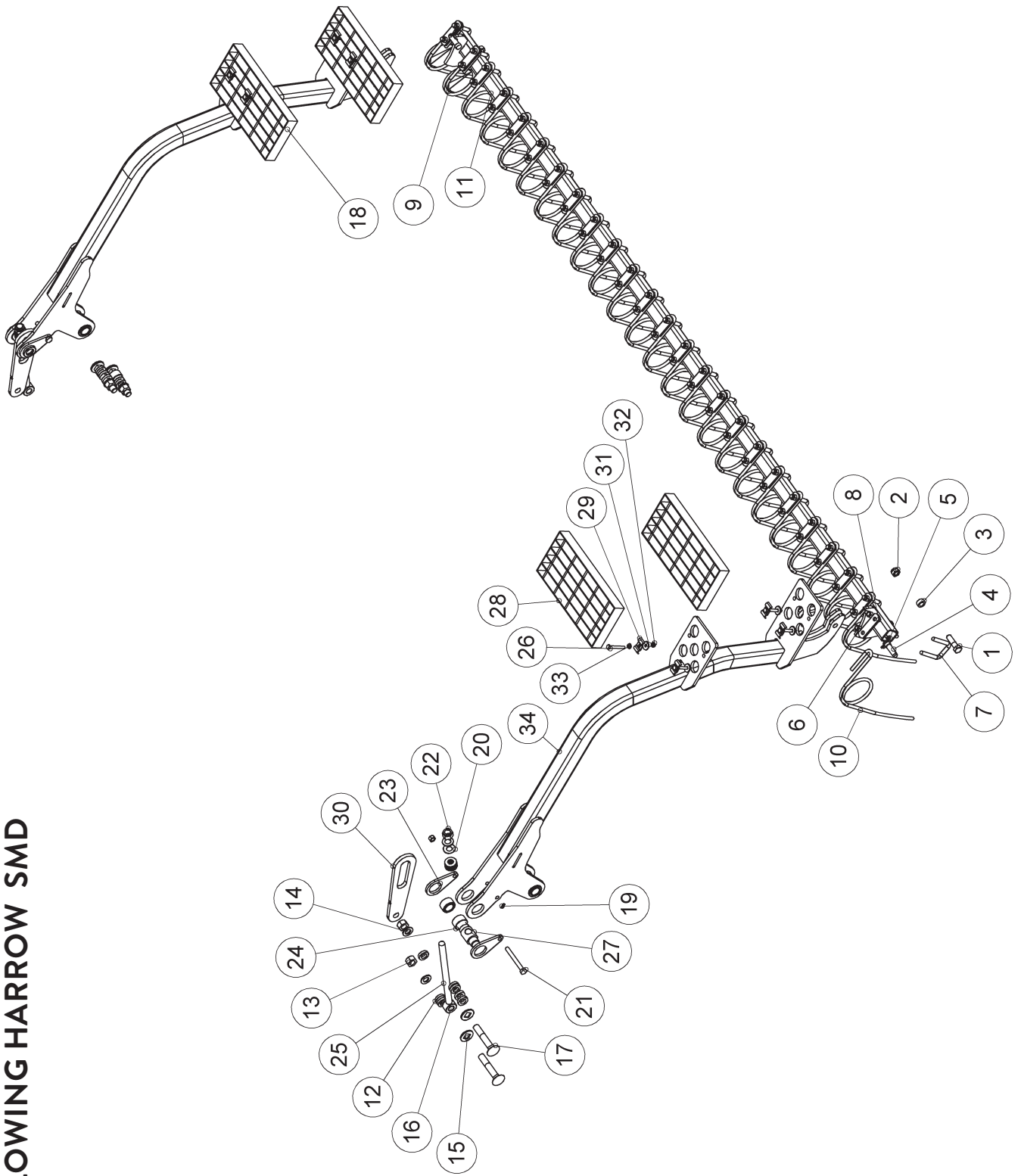

A GOOD WAY TO WORK HARD

OSA PART	KOODI CODE	NIMITYS	DESCRIPTION	SM300	SM400	D300	D400
1	A0G201514	6-RUUVI M16X60 8.8 Din931 Zn	SCREW	2	2	2	2
2	AGG113014	6-MUTTERI II M16 Din985-8 Zn	NUT	2	2	2	2
3	33601	VÄLIHOLKKI HARAAN	BUSHING	2	4	2	2
4	33425	TAPPI D16 L50	PIVOT	2	2	2	2
5	BD3011404	NEULASOKKA 4Mm Din11024 Zn	COTTER PIN	2	2	2	2
6	AGC113014	6-MUTTERI II M12 Din985-8 Zn	NUT	51	66	38	50
7	32422	U-PULTTI	U-SCREW	25	33	19	25
8	31139	VASTALATTA	PLATE	25	33	19	25
9	33351	JÄLKI HARAN PIIKKI OIK.	HARROW STICK	2	2	1	1
10	31674	JÄLKI HARAN PIIKKI 2013	HARROW STICK	23	31	18	24
11	31662	PIIKKIAKSELI HITS. 300	HARROW SHAFT	1		1	
	32425	PIIKKIAKSELI HITS. 400	HARROW SHAFT		1		1
12	31880	VÄLIHOLKKI 8x21x35	BUSHING	16	16	16	16
13	AGL111014	6-MUTTERI M20 Din934-8 Zn	NUT	4	4	4	4
14	B5L173024	ALUSLAATTA M20 Din125A Zn	WASHER	6	6	6	6
15	33350	ALUSLEVY LUKKORUUVI	WASHER	4	4	4	4
16	31634	HOLKKI	BUSHING	2	2	2	2
17	A0G2F6014	LUKKOR.M20X120 DIN603 ZN	SCREW	4	4	4	4
18	33873	OIKEA VARSII KOOTTU	HARROW ARM, RIGHT	1	1	1	1
19	BJ6150400	RASVANIPPA M6*1/Suora N 504	GREASE NIPPLE	2	2	2	2
20	B61472	LAUTASJOUSI 40*20.4*1.5	SPRING	20	20	20	20
21	A0C3L1514	6-RUUVI M12X110 8.8 Din 931Zn	SCREW	2	2	2	2
22	AGL113014	6-MUTTERI II M20 Din985-8 Zn	NUT	2	2	2	2
23	31669	KORVA TAPILLE	FLANGE	4	4	4	4
24	31671	HOLKKI LAIPPAAN	BUSHING	4	4	4	4
25	31633	KIERRETANKO	PIVOT	2	2	2	2
26	A08251312	6-RUUVI M8X65 8.8 Din 931 Zn	SCREW	8	8	8	8
27	31668	REAKTIOTANGON TAPPI	PIVOT	2	2	2	2
28	32519	TASORITILÄ L=382	GRILL	4	4	4	4
29	31175	KIINNIKE	HOLDER	8	8	8	8
30	36124	NOSTOTANKO	LIFTING BAR	2	2	2	2
31	B580V1544	KORILAATTA M 8 Din440R Zn	WASHER	8	8	8	8
32	AG8113014	6-MUTTERI II M 8 Din985-8 Zn	NUT	8	8	8	8
33	B580H1624	ALUSLAATTA M 8 Din125A Zn	WASHER	8	8	8	8
34	33870	HARAN VARSII HITS SMD	HARROW ARM	2	2	2	2
	36735	HARA SM 300 KOOTTU	HARROW SM 300				
	36736	HARA SM 400 KOOTTU	HARROW SM 400				
	36737	HARA D 300 KOOTTU	HARROW D 300				
	36738	HARA D 400 KOOTTU	HARROW D 400				
	33872	VARSII, VASEN KOOTTU	HARROW ARM, LEFT				
	33873	VARSII, OIKEA KOOTTU	HARROW ARM, RIGHT				
	31664	HARAPUTKI SM300 KOOTTU	HARROW SHAFT SM300				
	32424	HARAPUTKI SM400 KOOTTU	HARROW SHAFT SM400				
	33269	HARAPUTKI D300 KOOTTU	HARROW SHAFT D300				
	33361	HARAPUTKI D400 KOOTTU	HARROW SHAFT D400				

4. AJOTIETOKONE CONTROL UNIT

4.1 KOMPONENTIT COMPONENTS

NÄYTTÖ+kotelo
MONITOR+CASING

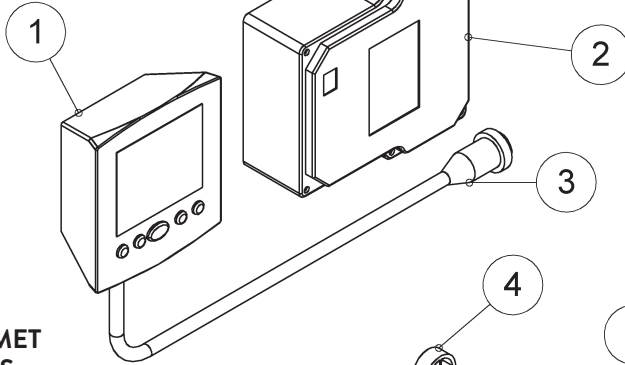

ANTURIT
SENSORS

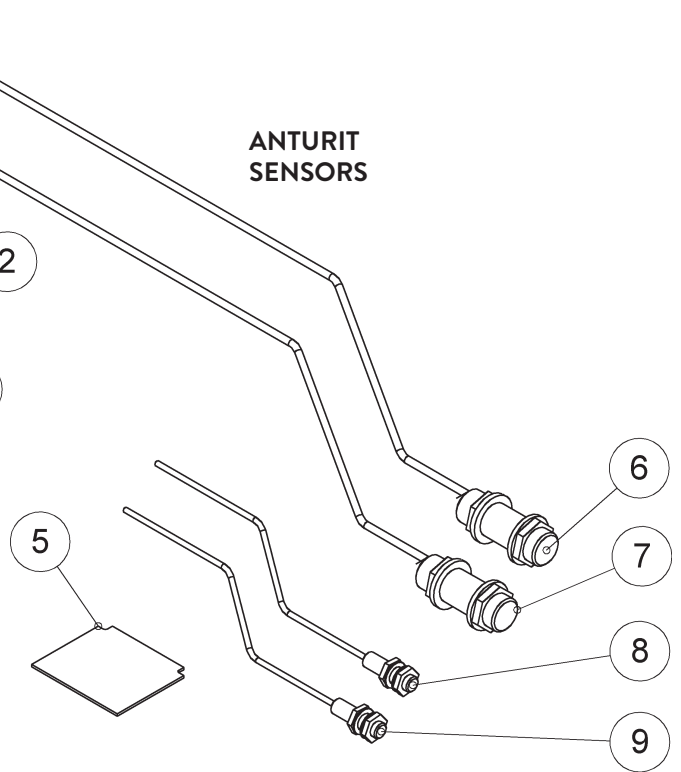

KIINNITTIMET
FASTENERS

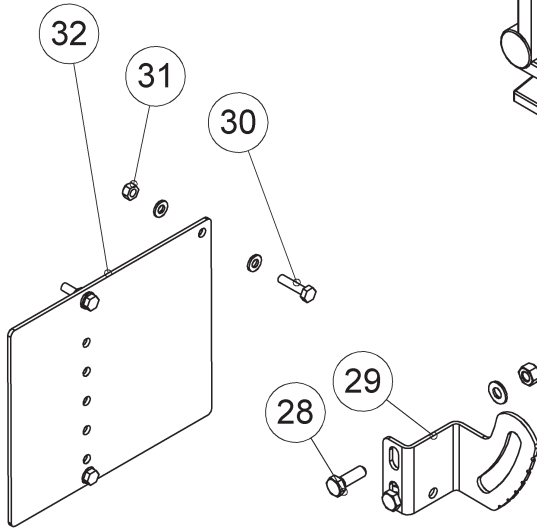

KAUKOSÄÄTÖ
REMOTE CONTROL

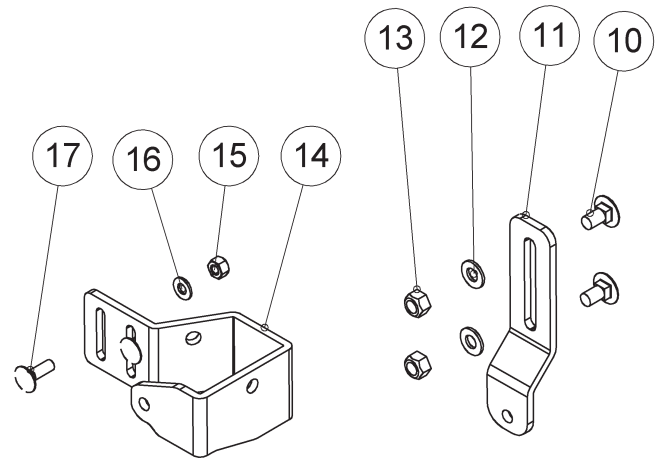

HARAN PUOLINOSTO
HALF LIFT OF THE HARROW

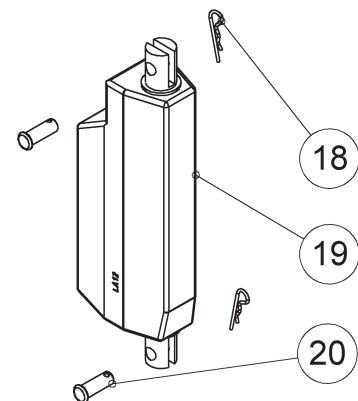
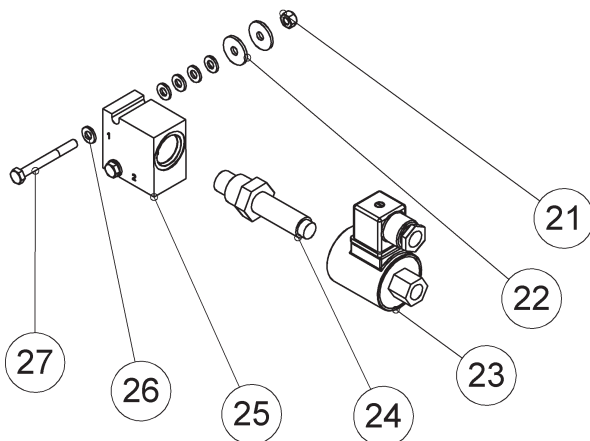

A GOOD WAY TO WORK HARD

OSA PART	KOODI CODE	NIMITYS	DESCRIPTION	KPL/PCS
1	31771	G-WIZ NÄYTTÖ	MONITOR	1
2	M744-050	KOTELO	CASING	1
3	S/CB/306-1-021	KAAPELI NÄYTÖLTÄ	CABLE	1
4	K/WIZ/MTG/BKT	WIZARD KIINN.JALKA K/WIZ/MTG/ BKT	MONITOR FIXTURE	1
5	S/A341-008 3-22856	PIIRIKORTTI	CIRCUIT BOARD	1
		ISOBUS ECU	ISOBUS ECU	1
6	S/F713-009	PINTAVAHTI RDS	LEVEL SENSOR	1
7	S/F713-009	PINTAVAHTI RDS	LEVEL SENSOR	1
8	S/Z782-006	ANTURI NOPEUS/LASKURI	SPEED SENSOR	1
9	S/Z782-006	ANTURI NOPEUS/LASKURI	SPEED SENSOR	1
10	A0A0L3014	LUKKOR.M10X20 4.6 DIN 603 ZN	SCREW	2
11	21181	LINAKIN KIINNIKE	LINAK HOLDER	1
12	B5A0MB024	ALUSLAATTA M10 DIN125A ZN	WASHER	2
13	AGA113014	6-MUTTERI II M10 DIN985-8 ZN	NUT	2
14	33237	KIINNITYSLEVY SÄHKÖSYL.	HOLDER	1
15	AG8113014	6-MUTTERI II M 8 DIN985-8 ZN	NUT	3
16	B580H1624	ALUSLAATTA M 8 DIN125A ZN	WASHER	2
17	A080S3014	LUKKOR. M8X25 4.6 DIN 603 ZN	SCREW	2
18	BD2000004	NEULASOKKA 2M _m DIN11024 ZN	COTTER PIN	2
19	D40600	SYL.LINAK LA12.1P-100-12-011P65	LINAK CYLINDER	1
20	BE1434	SOKKATAP+REIKÄ SINKKELT 10X28	PIVOT	2
21	AG6113014	6-MUTTERI II M 6 DIN985-8 ZN	NUT	2
22	B560N1524	KORILAATTA M 6 DIN9021 ZN	WASHER	4
23	6356012	KELA	INDUCTOR	1
24	SV10-23-0-N-00	PATRUUNA	CARTRIDGE	1
25	HF109048	PUOLINOSTOVENTTIILI LOHKO	VALVE BLOCK	1
26	B560E1524	ALUSLAATTA M 6 DIN125A ZN	WASHER	16
27	A03558	6-RUUVI M6X55 8.8 DIN 933 ZN	SCREW	2
28	A080S1514	6-RUUVI M8X25 8.8 DIN933 ZN	SCREW	2
29	32640	NOSTO/LASKUANTIRURIN PIDIN	SENSOR HOLDER	1
30	A060S1514	6-RUUVI M6X25 8.8 DIN 933 ZN	SCREW	3
31	AG5113014	6-MUTTERI II M 5 DIN985-8 ZN	NUT	3
32	31194	G-WIZ ALUSTA	FASTENER PLATE	1

4.2PINTA-ALAMITTARI SURFACE AREA METER

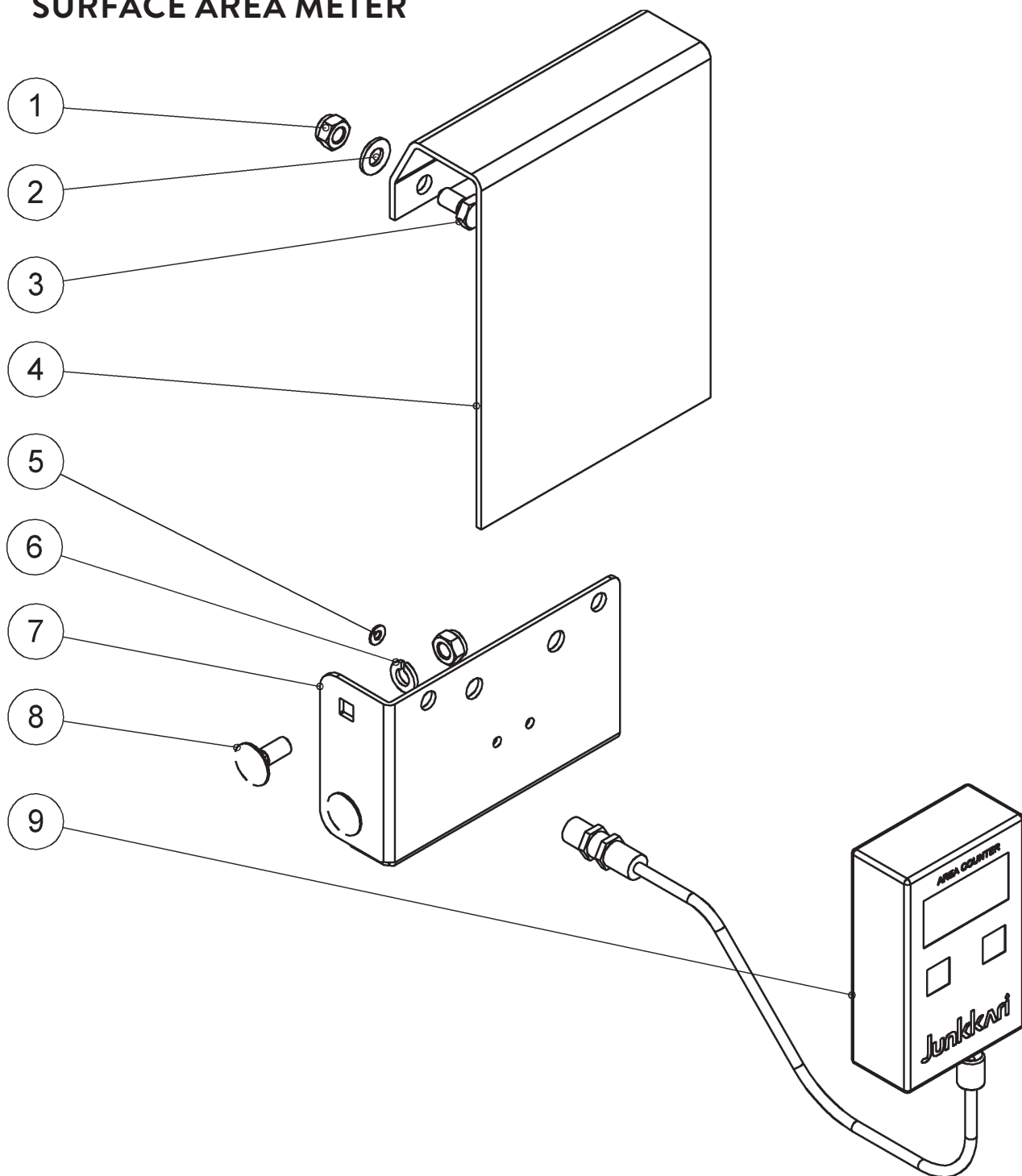

OSA PART	KOODI CODE	NIMITYS	DESCRIPTION	KPL/PCS
1	AG8113014	6-MUTTERI II M 8 DIN985-8 ZN	NUT	4
2	B580H1624	ALUSLAATTA M 8 DIN125A ZN	WASHER	2
3	A080G1514	6-RUUVI M8X16 8.8 DIN 933 ZN	SCREW	2
4	19688	SUOJEVERHO	COVER	1
5	B540C1524	ALUSLAATTA M 4 DIN125A ZN	WASHER	2
6	B580E2014	JOUSIALUSL.M 8 DIN127B ZN	SPRING WASHER	2
7	33289	PA-MITTARIN ALUSTA LYKKETRONIC	FASTENER PLATE	1
8	A05150	LUKKORUUVI M8X20 A2 DIN 603	SCREW	2
9	21282	LYKKETRONIC AREA METER	LYKKETRONIC AREA METER	1
	33290	PA-MITTARI KP MSD-MALLIT KOOTTU	AREA METER	

5. VETOAISA DRAW BOOM

5.1 VETOAISA S, VETOKOUKULLE DRAW BOOM S, FOR TOWING HOOK

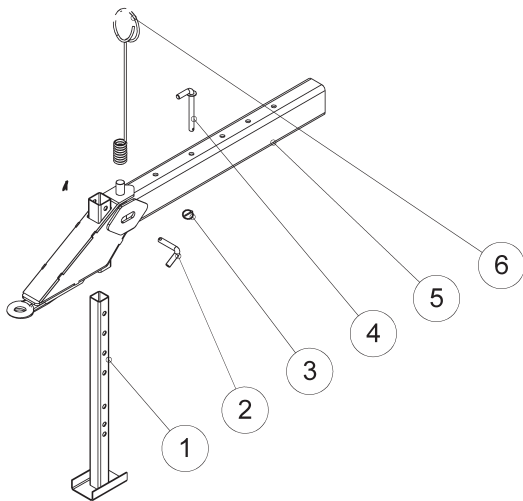

OSA PART	KOODI CODE	NIMITYS	DESCRIPTION	KPL/PCS
1	14506	TUKIJALKA HITSATTU	SUPPORT BAR	1
2	17605	SEISONTAJALAN TAPPI 20MM	PIVOT	1
3	BE8600002	RENGAS-SOKKA 8X45 L=040 ZN	LINCHPIN	2
4	14504	VETOLAITTEEN TAPPI HITS.	PIVOT	1
5	14309C	VETOPUOMI HITS.	DRAW BAR	1
6	26858	HYDRAULILETKUN KANNATIN Ø9	HOSE HOLDER	1

5.2 VETOAISA S, VETOKIDALLE DRAW BOOM S, FOR MAW

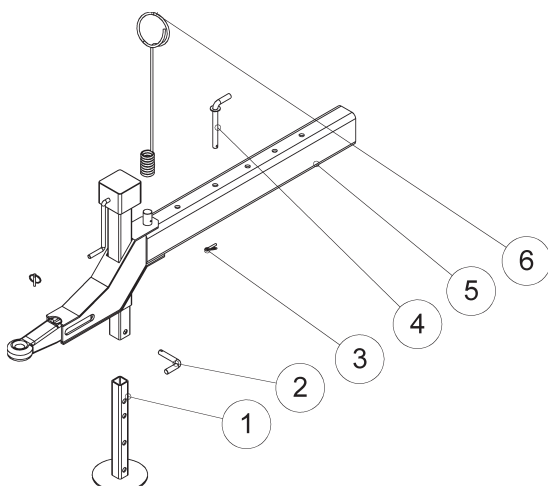

OSA PART	KOODI CODE	NIMITYS	DESCRIPTION	KPL/PCS
1	15679	PUTKEN JATKE HITSATTU	SUPPORT BAR	1
2	17605	SEISONTAJALAN TAPPI 20MM	PIVOT	1
3	BE8600002	RENGAS-SOKKA 8X45 L=040 ZN	LINCHPIN	2
4	14504	VETOLAITTEEN TAPPI HITS.	PIVOT	1
5	16107	VETOPUOMI TUV VETOSILMÄLLÄ	DRAW BAR	1
6	26858	HYDRAULILETKUN KANNATIN Ø9	HOSE HOLDER	1

5.3 VETOAISA S, PAKKERILLE DRAW BOOM S, FOR PACKER

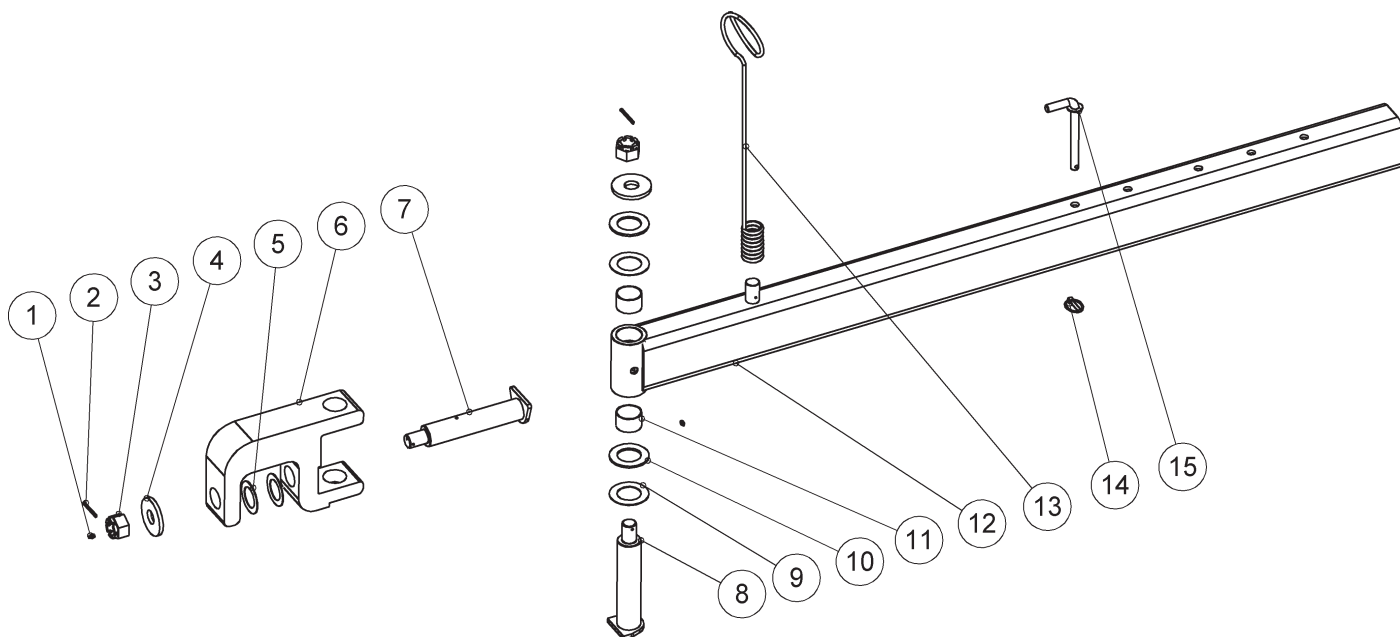

OSA PART	KOODI CODE	NIMITYS	DESCRIPTION	KPL/PCS
1	BJ6500000	RASVANIPPA M 8*1.25 N:O 507	GREASE NIPPLE	2
2	BA5200004	SAKSISOKKA 5X60 DIN94 ZN	SPLIT PIN	2
3	E73742	KRUUNUMUTTERI M 36*1.5 DIN 935	NUT	2
4	867190P	ALUSLEVY 100/37-10	WASHER	2
5	14858	PAINELAAKERI NIVELEEN	BEARING	2
6	33271	VETOAISAN KIINNITYSPALA PAKKER	FASTENER PIECE	1
7	20854	VAAKATAPPI HITS	PIVOT	1
8	33278	PYSTYTAPPI	PIVOT	1
9	CV0600705	DYMET PAINELAAKERI 705-60	BEARING	2
10	18568	VÄLIRENGAS 5MM	FITTING WASHER	2
11	CV0656040	DYMET LAAKERI 701 60/65/40	BEARING	2
12	14857	VETOAISA HITSATTU	DRAW BAR	1
13	26858	HYDRAULILETKUN KANNATIN Ø9	HOSE HOLDER	1
14	BE8600002	RENGAS-SOKKA 8X45 L=040 ZN	LINCHPIN	1
15	14504	VETOLAITTEEN TAPPI	PIVOT	1

5.4 VETOAISA SMD, VETOKOUKULLE
DRAW BOOM SMD, FOR TOW BAR

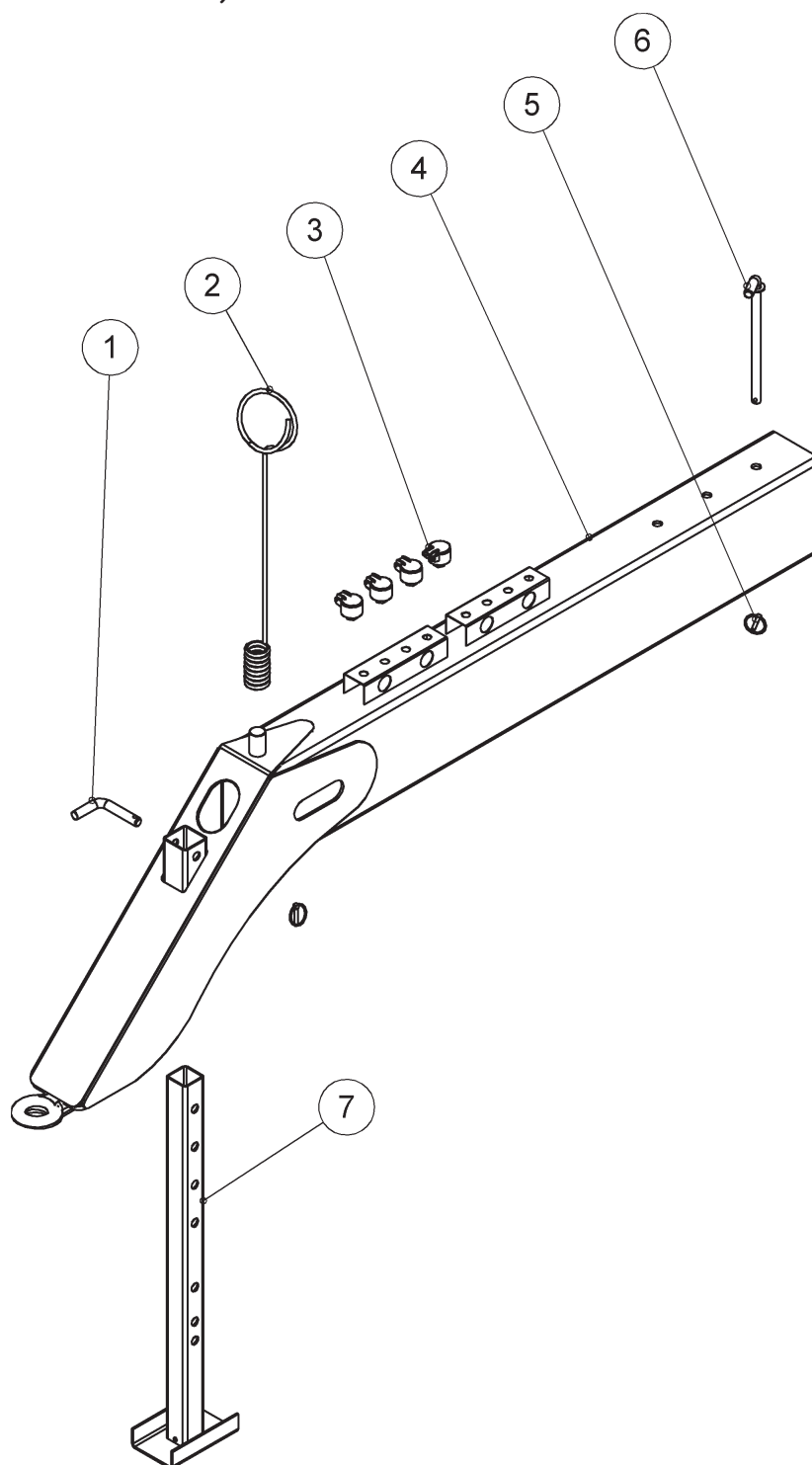

OSA PART	KOODI CODE	NIMITYS	DESCRIPTION	LYHYT/ SHORT	KESKIPITKÄ/ MEDIUM	PITKÄ/ LONG
1	17605	SEISONTAJALAN TAPPI 20MM	PIVOT	1	1	1
2	26858	HYDRAULILETKUN KANNATIN Ø9	HOSE HOLDER	1	1	1
3	D24323	LETKUN KIINNITIN AMA 15356	HOSE FASTENER	4	4	4
4	22248	VETOAISA HITSATTU 3/4 MINI	DRAW BAR	1		
	20724	VETOAISA HITSATTU 3/4	DRAW BAR		1	
	20886	VETOAISA HITSATTU 3/4 JUNA	DRAW BAR			1
5	BE8600002	RENGAS-SOKKA 8X45 L=040 ZN	LINCHPIN	2	2	2
6	20804	VETOLAITTEEN TAPPI 2010	PIVOT	1	1	1
7	14506	TUKIJALKA HITSATTU	SUPPORT BAR	1	1	1

5.5 VETOAISA SMD, PAKKERILLE
DRAW BOOM SMD, FOR PACKER

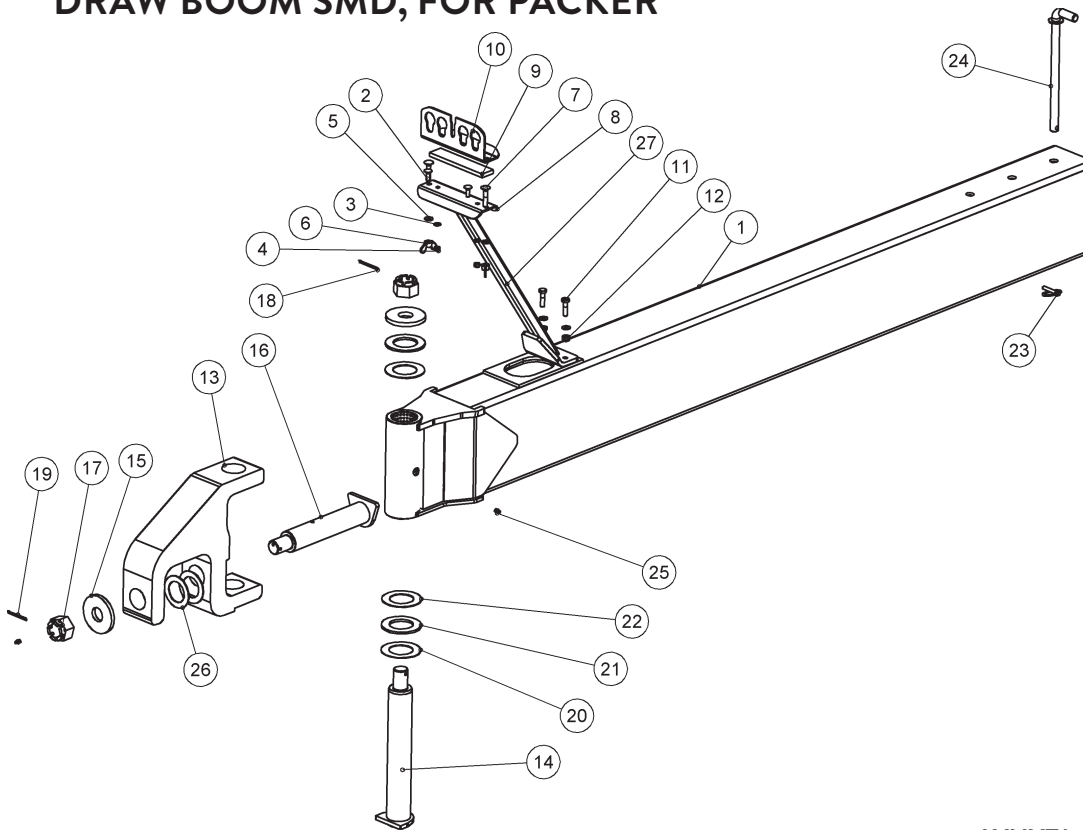

OSA PART	KOODI CODE	NIMITYS	DESCRIPTION	LYHYT/ SHORT	KESKIPITKÄ/ MEDIUM	PITKÄ/ LONG
1	22249	AISA PAKKERILLE HITS 2010 MINI	DRAW BAR	1		
	20809	AISA PAKKERILLE HITS 2010	DRAW BAR		1	
	20888	AISA PAKKERILLE PITKÄ HITS 201	DRAW BAR			1
2	A080S3014	LUKKOR M8X25 4.6 Din 603 Zn	SCREW	2	2	2
3	B60649	ALUSLAATTA M 8 Din125A A2 Aisi	WASHER	2	2	2
4	A50711	6-MUTTERI M8 Nyloc 985 Zn	NUT	2	2	2
5	628962	ALUSLAATTA 30.5/12 X 4	WASHER	4	4	4
6	AGA11J014	SIIPIMUTTERI M10 Din315 Zn	NUT	2	2	2
7	A0A1A3015	LUKKOR.M10X50 4.6 Din 603 Zn	SCREW	2	2	2
8	36713	ALALEVY	PLATE	1	1	1
	36714	ALALEVY PITKÄ	PLATE	1	1	1
9	36717	SOLUMUOVI 10x40 L=185	CELLULAR PLASTIC	1	1	1
	36718	SOLUMUOVI 10X40 L=295	CELLULAR PLASTIC	1	1	1
10	36715	YLÄLEVY LYHYT	PLATE	1	1	1
	36716	YLÄLEVY PITKÄ	PLATE	1	1	1
11	A07552	6-RUUVI M10X40 8.8 Din 933 Znc	SCREW	2	2	2
12	A51151	6-MUTTERI II M10 Aisi	NUT	2	2	2
13	20851	VETOAISAN KIINNITYSPALA	PLATE	1	1	1
14	21302	PYSTYTAPPI	PIVOT	1	1	1
15	867190P	ALUSLEVY 100/37-10	WASHER	2	2	2
16	20854	VAAKATAPPI HITS	PIVOT	1	1	1
17	E73742	KRUUNUMUTTERI M 36*1.5 Din 935	NUT	2	2	2
18	BA5200004	SAKSISOKKA 5X60 Din94 Zn	COTTER PIN	1	1	1
19	BA5200004	SAKSISOKKA 5X60 Din94 Zn	COTTER PIN	1	1	1
20	18641	VÄLIRENGAS 1.5 MM	WASHER	1	1	1
21	18568	VÄLIRENGAS 5MM	WASHER	2	2	2
22	CV0600705	DYMET PAINELAAKERI 705-60	BEARING	2	2	2
23	BE8600002	RENGAS-SOKKA 8X45 L=040 Zn	LINCHPIN	1	1	1
24	20804	VETOLAITTEEN TAPPI 2010	PIVOT	1	1	1
25	BJ6500000	RASVANIPPA M 8*1.25 N:O 507	GREASE NIPPLE	2	2	2
26	14858	PAINELAAKERI NIVELEEN	BEARING	2	2	2
27	36710	LETKUNKANNATIN HITS.	HOSE HOLDER	1	1	1

5.6 VETOAISJOJEN LETKUTUKSET HOSES OF THE DRAW BOOMS

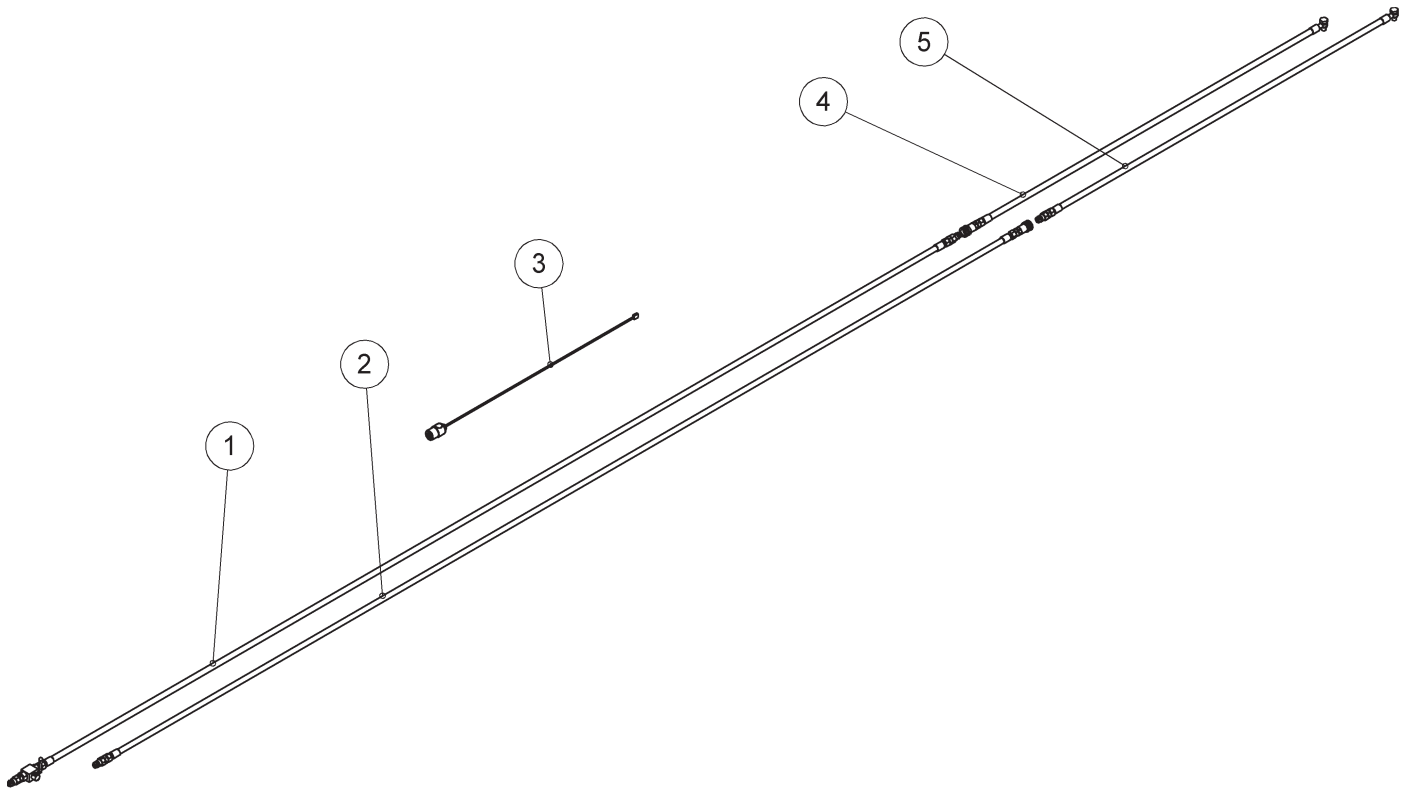

OSA PART	KOODI CODE	NIMITYS	DESCRIPTION	KITA, PAKKERI/ KOUKKU/ PACKER MAW, TOW BAR
1	33250	HYDRAULILETKU NOSTO 4800	HOSE 4800	1
	33413	HYDRAULILETKU NOSTO 6800	HOSE 6800	1
2	33249	HYDRAULILETKU LASKU 4800	HOSE 4800	1
	33409	HYDRAULILETKU LASKU 6800	HOSE 6800	1
3	CP44882	PÄÄJOHTO L=6,0 m	WIRE 6000	1
	CP44880	PÄÄJOHTO L=8,0 m	WIRE 8000	1
4	33408	HYDRAULILETKU ETUMM.	HOSE, FRONT	1
5	33407	HYDRAULILETKU TAKIMM.	HOSE, REAR	1

5.7 PAKKERI PIENI SMD
PACKER SMALL SMD

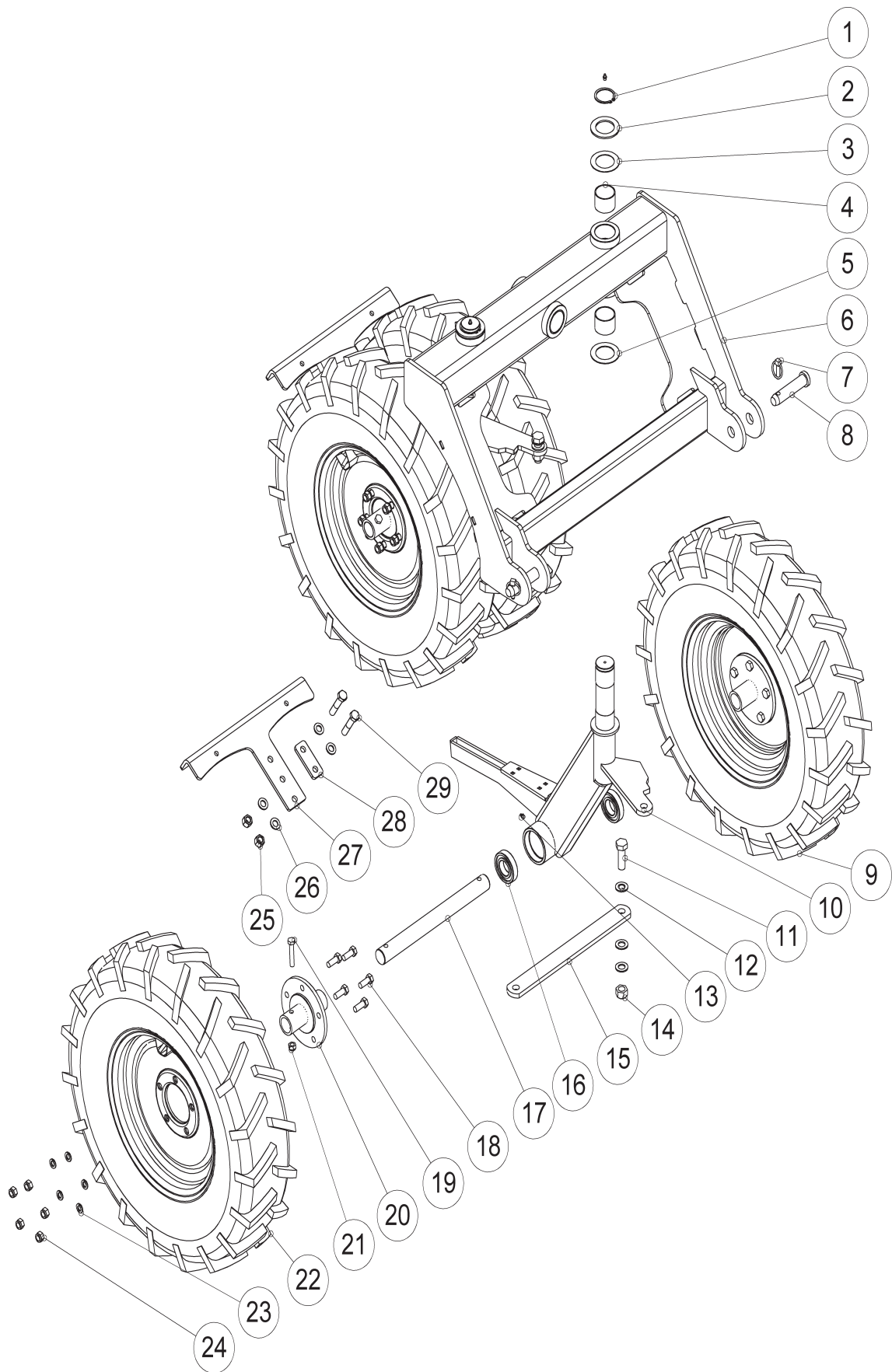

A GOOD WAY TO WORK HARD

OSA PART	KOODI CODE	NIMITYS	DESCRIPTION	KPL/PCS
1	BH1S20021	SEGER-RENG AKS 55X2 471	CIRCLIP	2
2	14846	ALUSLEVY OLKATAPPIIN	WASHER	2
3	14846A	ALUSLEVY 1.5 OLKATAPPIIN	WASHER	2
4	CV0556040	DYMET LAAKERI 55/60/40	BEARING	6
5	14858	PAINELAAKERI NIVELEEN	BEARING	2
6	33727	VETOR. PAKKERIIN 7.5X16 PYÖRILLE	FRAME	1
7	BEC000002	RENGAS-SOKKA 10X40 L=40 ZN	LINCHPIN	2
8	14861	NOSTOVARREN TAPPI	PIVOT	2
9	D18355	RENGAS KOOTTU 18355 MAESTRO	WHEEL	2
10	16501	TUKIVARSI PYÖRÄÄN HITS.VAS	SUPPORT BAR, LEFT	1
	14838	TUKIVARSI PYÖRÄÄN HITS.OIK.	SUPPORT BAR, RIGHT	1
11	A0L201524	6-RUUVI M20X60 8.8 DIN933 ZN	SCREW	2
12	B5L173024	ALUSLAATTA M20 DIN125A ZN	WASHER	6
13	BJ6500000	RASVANIPPA M 8*1.25 N:O 507	GREADE NIPPLE	4
14	A51902	6-MUTT.II M20*1.5 DIN960 ZN	NUT	2
15	14723	RAIDETANKO	TIE ROD	1
16	CE6208RS1	KUULALAAKERI 6208 RS 1	BEARING	4
17	14718	PYÖRÄN AKSELI	SHAFT	2
18	A0E151514	6-RUUVI M14X35 8.8 DIN933 ZN	SCREW	20
19	A0C251514	6-RUUVI M12X65 8.8 DIN931 ZN	SCREW	4
20	33414	NAPA HITS. 5-REIK.	HUB	4
21	AGC113014	6-MUTTERI II M12 DIN985-8 ZN	NUT	4
22	18358	RENGAS 7.5x16 KOOTTU VASEN	WHEEL, LEFT	2
23	B61255	JOUSIALUSL.M14 DIN127B ZN	SPRING WASHER	20
24	AGE113014	6-MUTTERI II M14 DIN 985 ZN	NUT	20
25	AGG113014	6-MUTTERI II M16 DIN985-8 ZN	NUT	4
26	B5G102524	ALUSLAATTA M16 DIN125A ZN	WASHER	8
27	33415	PAKKERIN RAAPIJA	SCRAPER	2
28	32467	ALUSLEVY	WASHER	2
29	A0G2L1514	6-RUUVI M16X80 8.8 DIN931 ZN	SCREW	4

5.8PAKKERI ISO SMD
PACKER BIG SMD

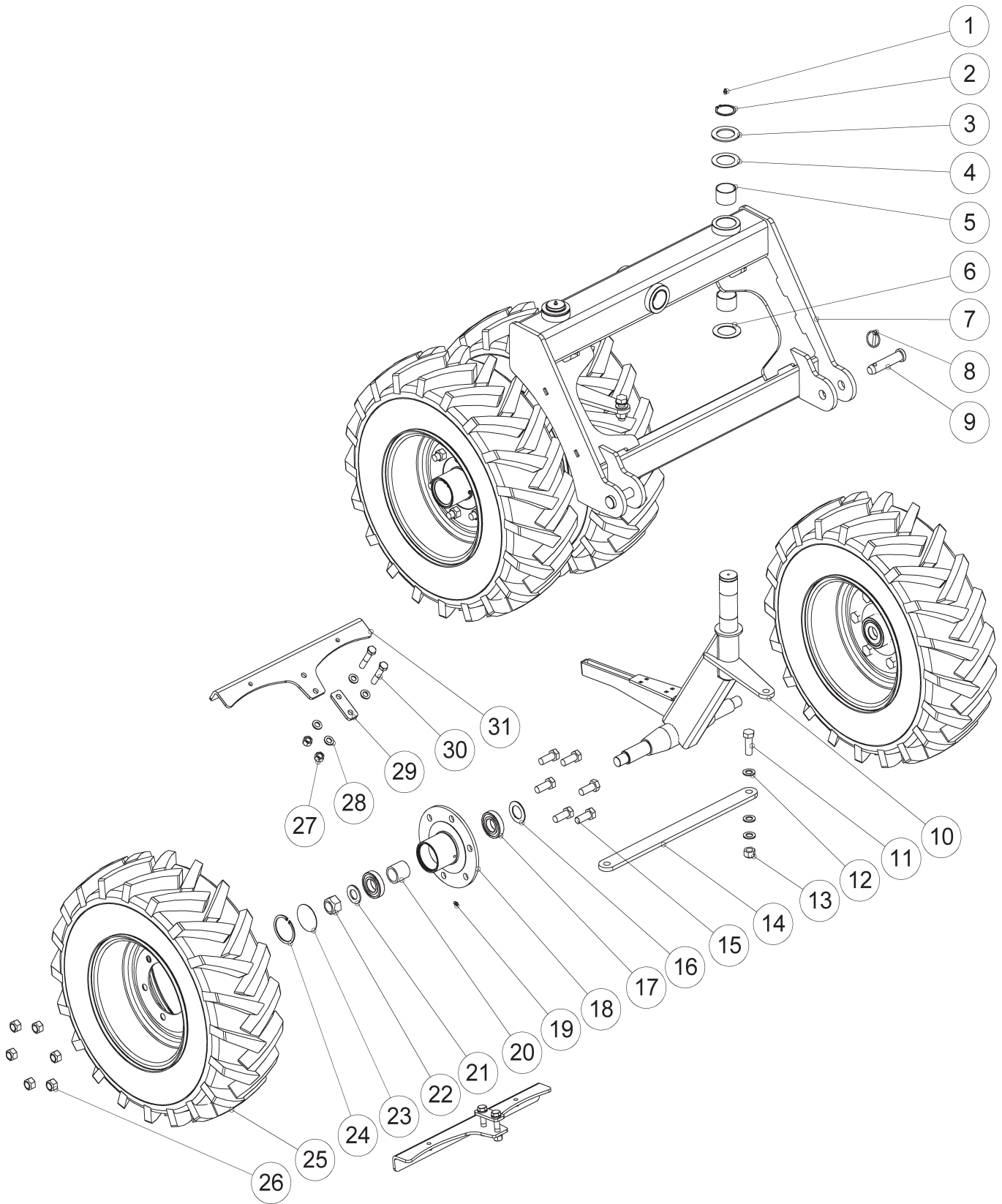

A GOOD WAY TO WORK HARD

OSA PART	KOODI CODE	NIMITYS	DESCRIPTION	KPL/PCS
1	BJ6500000	RASVANIPPA M 8*1.25 N:O 507	GREASE NIPPLE	2
2	BH1S20021	SEGER-RENG AKS 55X2 471	CIRCLIP	2
3	14846	ALUSLEVY OLKATAPPIIN	WASHER	2
4	14846A	ALUSLEVY 1.5 OLKATAPPIIN	WASHER	2
5	CV0556040	DYMET LAAKERI 55/60/40	BEARING	6
6	14858	PAINELAAKERI NIVELEEN	BEARING	2
7	32494	VETORUNKO PAKKERIIN	FRAME	1
8	BE8600002	RENGAS-SOKKA 8X45 L=040 ZN	LINCHPIN	2
9	14861	NOSTOVARREN TAPPI	PIVOT	2
10	32506	PYÖRIEN KÄSIVARSI VASEN HITS.	SUPPORT BAR, RIGHT	1
	32509	PYÖRIEN KÄSIVARSI OIKEA HITS.	SUPPORT BAR, RIGHT	1
11	A0L201524	6-RUUVI M20X60 8.8 DIN933 ZN	SCREW	2
12	B5L173024	ALUSLAATTA M20 DIN125A ZN	WASHER	6
13	A51902	6-MUTT.II M20*1.5 DIN960 ZN	NUT	2
14	16068	RAIDETANKO	TIE ROD	1
15	A0L1F1214	6-RUUVI M20X1.5X50 8.8 DIN961ZN	SCREW	20
16	16059	SUOJAPRIKKA	WASHER	4
17	CE62082RS	KUULALAAKERI 6208 2 RS	BEARING	8
18	32462	NAPA HITS.	HUB	4
19	BJ6510001	RASVANIPPA M 8*1.25/45AST514	GREASE NIPPLE	4
20	32468	VÄLIHOLKKI	BUSHING	4
21	B61850	ALUSLAATTA M30 DIN125A ZNC	WASHER	4
22	A51970	6-MUTTERI II M30X3.5 DIN985-8NM30 ZN	NUT	4
23	32464	SUOJALEVY	COVER PLATE	4
24	BH3030085	SEGER-RENG REI 85X3472	CIRCLIP	4
25	D30011	10.0/75-15.3 10PR TL AS-504	WHEEL	4
26	A51900	6-MUTTERI M20X1.5 DIN934-8 ZN	NUT	20
27	AGG113014	6-MUTTERI II M16 DIN985-8 ZN	NUT	4
28	B5G102524	ALUSLAATTA M16 DIN125A ZN	WASHER	8
29	32467	ALUSLEVY	WASHER	2
30	A0G2L1514	6-RUUVI M16X80 8.8 DIN931 ZN	SCREW	4

6. LISÄVARUSTEET ACCESSORIES

6.1 ETULATA SMD, 1-RIVINEN FRONT LEVELLER SMD, 1-ROW

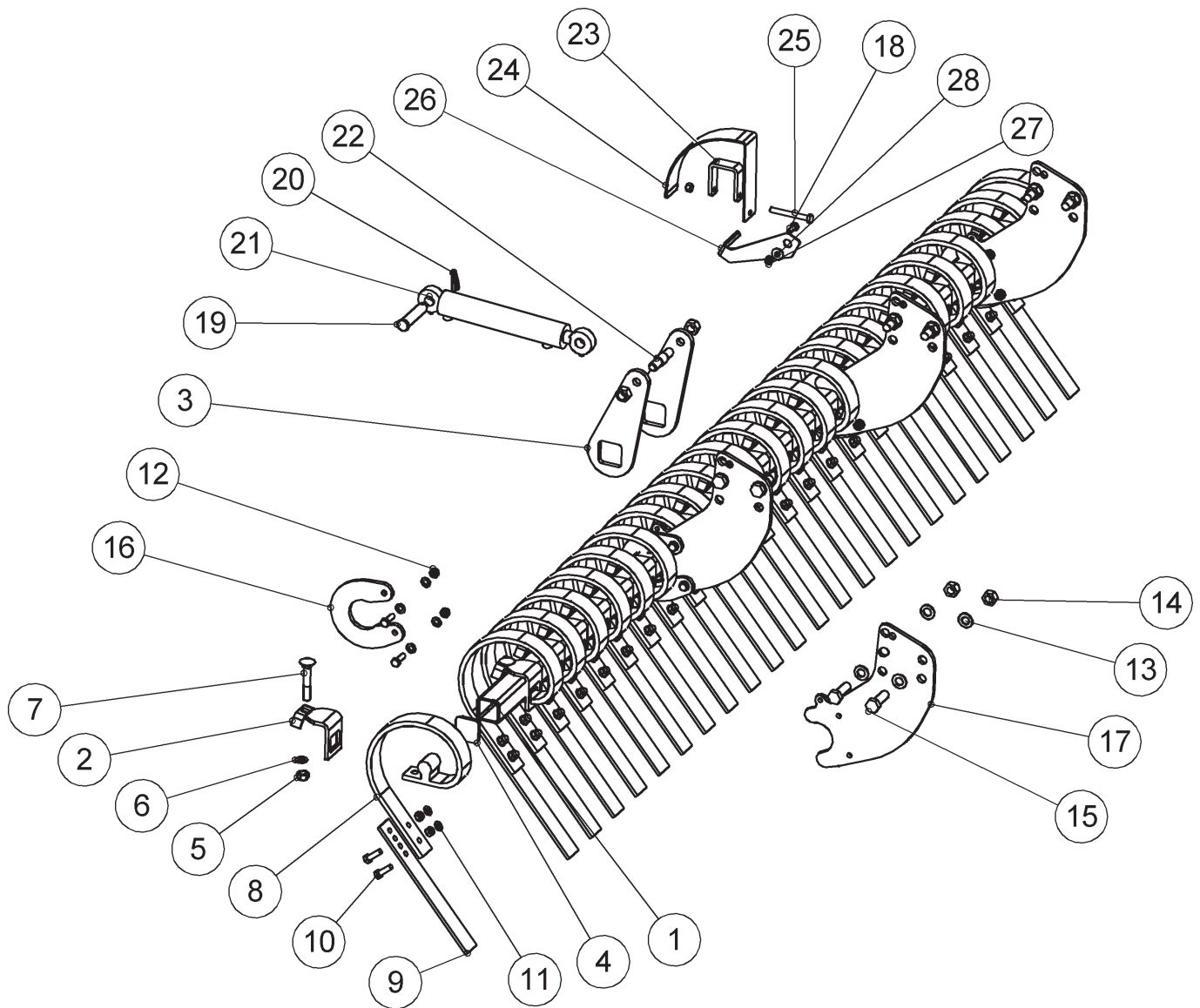

OSA PART CODE	KOODI	NIMITYS	DESCRIPTION	S300		S400		M300		M400		D300		D400	
				ETULATA FRONT	ETULATA FRONT	ETULATA FRONT	ETULATA FRONT	ETULATA FRONT	ETULATA FRONT	ETULATA FRONT	ETULATA FRONT	ETULATA FRONT	ETULATA FRONT	ETULATA FRONT	
1	17284	PALKKI RUNKOON	BAR	1	1	1	1	1	1	1	1	1	1	1	1
2	18073	PALKKI RUNKOON	BAR	24	32	32	24	32	24	32	24	32	24	32	32
3	33521	JOUSEN KIINNITIN SMD	SPRRING HOLDER	2	2	2	2	2	2	2	2	2	2	2	2
4	33047	VIPUVARSI	ARM	2	2	2	2	2	2	2	2	2	2	2	2
5	D60605	SISÄTULPPA 60*60*5	PLUG	24	32	32	24	32	24	32	24	32	24	32	32
6	AGG113014	6-MUTTERI II M16 Din985-8 Zn	NUT	24	32	32	24	32	24	32	24	32	24	32	32
7	B5G102524	ALUSLAATTA M16 Din125A Zn	WASHER	24	32	32	24	32	24	32	24	32	24	32	32
8	A0G2F5015	LUKKORUUVI M16x100	SCREW	24	32	32	24	32	24	32	24	32	24	32	32
9	33498	JOUSI SMD ETULATA	SPRING	24	32	32	24	32	24	32	24	32	24	32	32
10	33499	ETULATAN LATA KAPEA	HARROW	24	32	32	24	32	24	32	24	32	24	32	32
11	A0C1A1014	6-RUUVI M12X40 8.8 Din933 Zn	SCREW	56	72	72	56	72	56	72	56	72	56	72	72
12	B5C0R2024	ALUSLAATTA M12 Din125A Zn	WASHER	64	80	80	64	80	64	80	64	80	64	80	80
13	AGC113014	6-MUTTERI II M12 Din985-8 Zn	NUT	56	72	72	56	72	56	72	56	72	56	72	72
14	B5L173024	ALUSLAATTA M20 Din125A Zn	WASHER	16	16	16	16	16	16	16	16	16	16	16	16
15	AGL113014	6-MUTTERI II M20 Din985-8 Zn	NUT	10	10	10	10	10	10	10	10	10	10	10	10
16	A0L201524	6-RUUVI M20X60 8.8 Din933 Zn	SCREW	8	8	8	8	8	8	8	8	8	8	8	8
17	36747	KIINNITYSKORVA	BRACKET	4	4	4	4	4	4	4	4	4	4	4	4
	36478	KIINNITYSLEVY	FASTENER PLATE	4	4	4	4	4	4	4	4	4	4	4	4
	36751	KIINNITYSLEVY	FASTENER PLATE												
	36749	KIINNITYSLEVY	FASTENER PLATE												
	33746	KIINNITYSLEVY	FASTENER PLATE												
18	A0A101524	6-RUUVI M10X30 8.8 Din933 Zn	SCREW	1	1	1	1	1	1	1	1	1	1	1	1
19	17757	TAPPI SYLINTERILLE	PIVOT	1	1	1	1	1	1	1	1	1	1	1	1
20	BE8600002	RENGAS-SOKKA 8X45 L=040 Zn	LINCHPIN	1	1	1	1	1	1	1	1	1	1	1	1
21	D56044	HYD.SYL.Nts4-50/30*200-2B25/3/	CYLINDER	1	1	1	1	1	1	1	1	1	1	1	1
	33747	HYD.SYL. 50/30*150	CYLINDER	1	1	1	1	1	1	1	1	1	1	1	1
22	17519	TAPPI LATAAN	PIVOT	1	1	1	1	1	1	1	1	1	1	1	1
23	17640	LUKITUSLAPPU	LOCK PLATE	1	1	1	1	1	1	1	1	1	1	1	1
24	18115	KAARI VIISARILLE	CURVE	1	1	1	1	1	1	1	1	1	1	1	1
25	A0C3A1014	6-RUUVI M12X100 8.8 Din931Zn	SCREW	1	1	1	1	1	1	1	1	1	1	1	1
26	18111	VIISARI LATALLE	POINTER	1	1	1	1	1	1	1	1	1	1	1	1
27	AGA113014	6-MUTTERI II M10 Din985-8 Zn	NUT	1	1	1	1	1	1	1	1	1	1	1	1
28	B5A0V1524	KORILAATTA M10 Din9021B Zn	WASHER	1	1	1	1	1	1	1	1	1	1	1	1
29	17909	LETKU 1-RIV. LATALLE	HOSE	2	2	2	2	2	2	2	2	2	2	2	2
	36746	ETULATA 1-RIV. S300 KP.	FRONT HARROW												
	36752	ETULATA 1-RIV. S400 KP.	FRONT HARROW												
	36748	ETULATA 1-RIV. M300 KP.	FRONT HARROW												
	36750	ETULATA 1-RIV. M400 KP.	FRONT HARROW												
	33745	ETULATA 1-RIV. D300 KP.	FRONT HARROW												
	33755	ETULATA 1-RIV. D400 KP.	FRONT HARROW												

6.2 ETULATA M, 1-RIVINEN ERILLISET LANN. VANTAAT FRONT LEVELLER M, 1-ROW

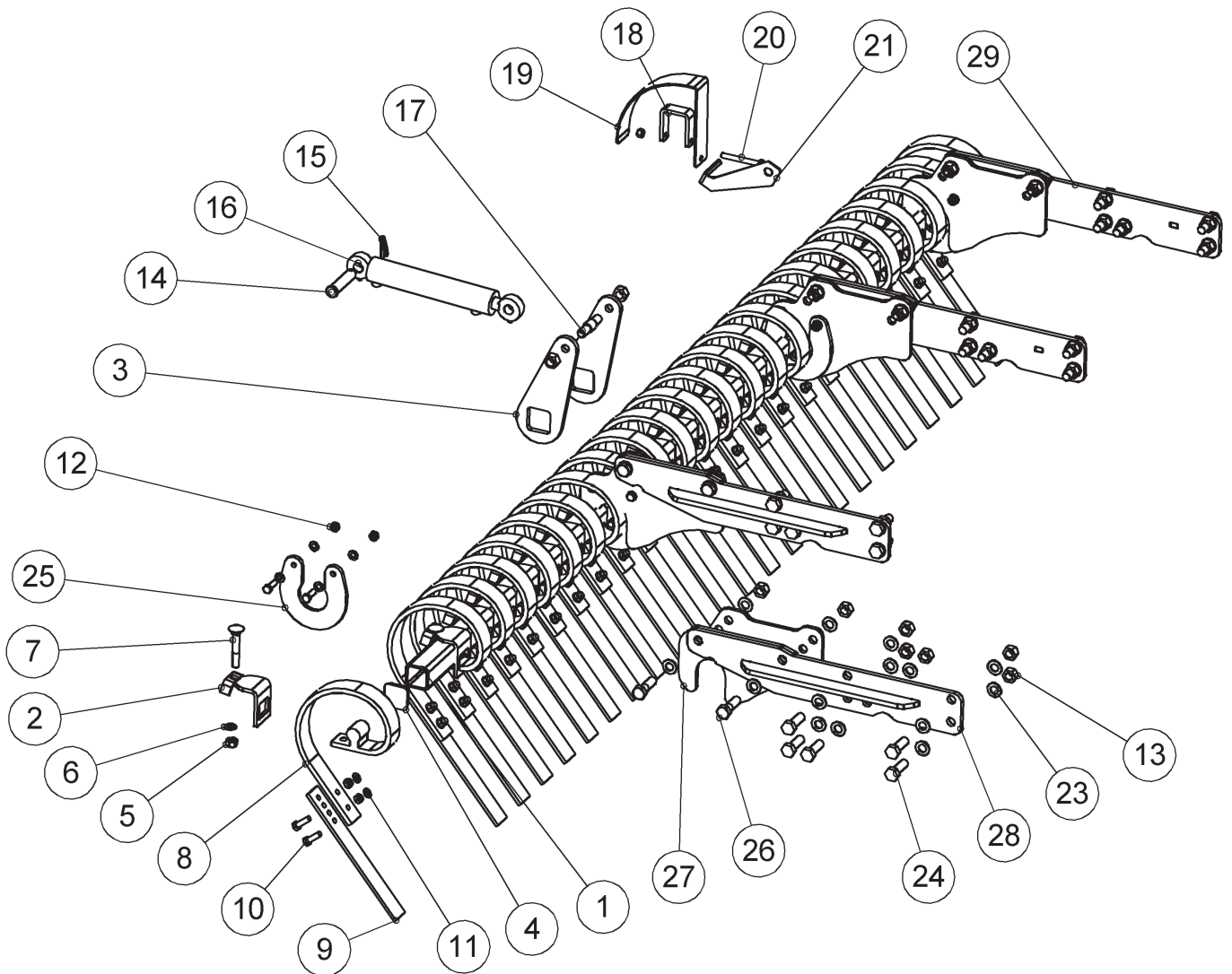

A GOOD WAY TO WORK HARD

OSA PART	KOODI CODE	NIMITYS	DESCRIPTION	M300	M400
				ETULATA FRONT HARROW	ETULATA FRONT HARROW
1	17284	PALKKI RUNKOON	BAR	1	
	18073	PALKKI RUNKOON	BAR		1
2	33521	JOUSEN KIINNITIN SMD ETULATA	SPRING HOLDER	24	32
3	33047	VIPUVARSI	ARM	2	2
4	D60605	SISÄTULPPA 60*60*5	PLUG	2	2
5	AGG113014	6-MUTTERI II M16 Din985-8 Zn	NUT	24	32
6	B5G102524	ALUSLAATTA M16 Din125A Zn	WASHER	24	32
7	A0G2F5015	LUKKORUUVI M16x100	SCREW	24	32
8	33498	JOUSI SMD ETULATA	SPRING	24	32
9	33499	ETULATAN LATA KAPEA	HARROW	24	32
10	A0C1A1014	6-RUUVI M12X40 8.8 Din933 Zn	SCREW	56	72
11	B5C0R2024	ALUSLAATTA M12 Din125A Zn	WASHER	64	80
12	AGC113014	6-MUTTERI II M12 Din985-8 Zn	NUT	9	9
13	AGL113014	6-MUTTERI II M20 Din985-8 Zn	NUT	30	30
14	17757	TAPPI SYLINTERILLE	PIVOT	1	1
15	BE8600002	RENGAS-SOKKA 8X45 L=040 Zn	LINCHPIN	1	1
16	D56044	HYD.SYL.Nts4-50/30*200-2B25/3/	CYLINDER	1	1
17	17519	TAPPI LATAAN	PIVOT	1	1
18	17640	LUKITUSLAPPU	LOCK PLATE	1	1
19	18115	KAARI VIISARILLE	CURVE	1	1
20	A0C3A1014	6-RUUVI M12X100 8.8 Din931Zn	SCREW	1	1
21	18111	VIISARI LATALLE	POINTER	1	1
22	17909	LETKU 1-RIV. LATALLE	HOSE	2	2
23	B5L173024	ALUSLAATTA M20 Din125A Zn	WASHER	56	56
24	A0L201524	6-RUUVI M20X60 8.8 Din933 Zn	SCREW	20	20
25	36747	KIINNITYSKORVA	BRACKET	4	4
26	A0L2A1014	6-RUUVI M20X70 8.8 Din931 Zn	SCREW	8	8
27	36749	KIINNITYSLEVY M	BRACKET	4	4
28	36756	KIINNIKE VAS.	BRACKET	2	2
29	36757	KIINNIKE OIK.	BRACKET	2	2
	36758	ETULATA 1-RIV. ERIL. LANN. VAN- TAAT M300 KP.			
	36755	ETULATA 1-RIV. ERIL. LANN. VANTAAT M400 KP.			

6.3 ETULATA MD, 2-RIVINEN
 S-PIIKKIMUOKKAIN MD, 2-RIVINEN
 FRONT LEVELLER, 2-ROW
 S-TINE MD, 2-ROW

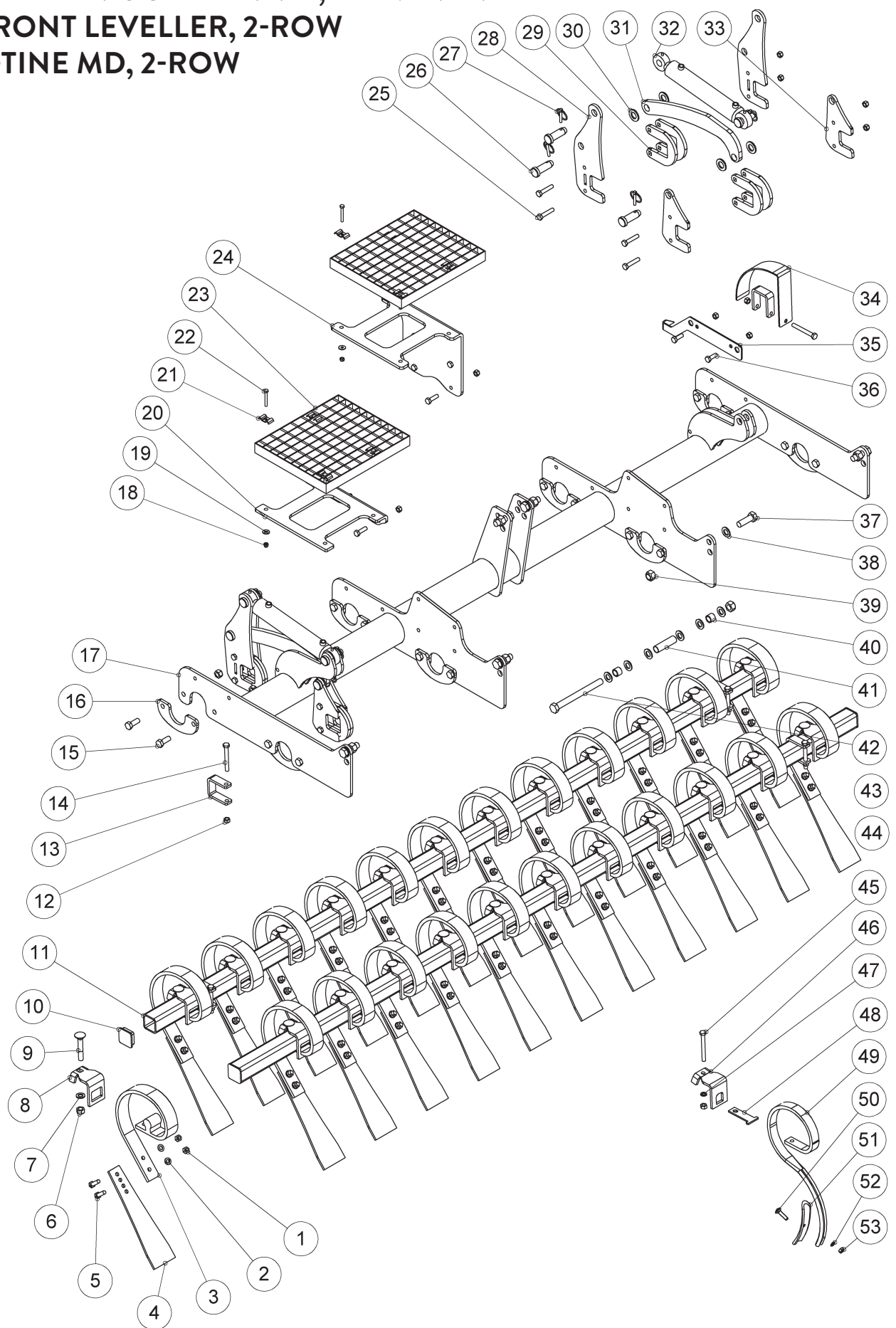

A GOOD WAY TO WORK HARD

OSA PART	KOODI CODE	NIMITYS	DESCRIPTION	MD300	MD400	MD300	MD400
				ETULATA FRONT HARROW	ETULATA FRONT HARROW	S-PIIKKI S-TINE	S-PIIKKI S-TINE
1	AGC111014	6-MUTTERI M12 DIN934-8 ZN	NUT	48	64	24	32
2	B5C0R2024	ALUSLAATTA M12 DIN125A ZN	WASHER	48	64		
3	33498	JOUSI SMD ETULATA	SPRING	24	32		
4	33526	ETULATAN LATA LEVEÄ	HARROW	24	32		
5	A0C1A1014	6-RUUVI M12X40 8.8 DIN933 ZN	SCREW	6	6	6	6
6	AGG113014	6-MUTTERI II M16 DIN985-8 ZN	NUT	41	48	16	16
7	B5G102524	ALUSLAATTA M16 DIN125A ZN	WASHER	24	32		
8	33521	JOUSEN KIINN. SMD ETULATA	SPRING HOLDER	24	32		
9	A0G2F5015	LUKKORUUVI M16x100	SCREW	24	32		
10	D60605	SISÄTULPPA 60*60*5	PLUG	4	4	4	4
11	17284	PALKKI RUNKOON	BAR	2		2	
	18073	KIINNITYSPALKKI 4000	BAR		2		2
12	AGC113014	6-MUTTERI II M12 DIN985-8 ZN	NUT	29	29	20	20
13	17640	LUKITUSLAPPU	LOCK PLATE	5	5	5	5
14	A0C3A1014	6-RUUVI M12X100 8.8 DIN931ZN	SCREW	5	5	5	5
15	A0G1A1514	6-RUUVI M16X40 8.8 DIN933 ZN	SCREW	16	16	16	16
16	32604	U-HAHLO LATAN AKS. KIINN.	U-PLATE	8	8	8	8
17	32596	RUNKO KAKSOISLATA 300	FRAME	1		1	
	33193	RUNKO KAKSOISLATA 400	FRAME		1		1
18	AG8113014	6-MUTTERI II M 8 DIN985-8 ZN	NUT	8	8	8	8
19	B580N1524	KORILAATTA M 8 DIN9021B ZN	WASHER	8	8	8	8
20	32606	ALA-ASTIMEN PETI	STEP COUNTERPART	1	1	1	1
21	31175	KIINNIKE	HOLDER	8	8	8	8
22	A05960	6-RUUVI M8X60 8.8 DIN 931 ZN	SCREW	8	8	8	8
23	32605	TASORITILÄ LATALLE	GRILL	2	2	2	2
24	32607	TOISEN ASKELMAN PETI	STEP COUNTERPART	1	1	1	1
25	A0C201514	6-RUUVI M12X60 8.8 DIN931 ZN	SCREW	8	8	8	8
26	D14446	SYLINTERIN TAPPI 14446	PIVOT	8	8	8	8
27	BE8600002	RENGAS-SOKKA 8X45 L=040 ZN	LINCHPIN	8	8	8	8
28	22786	KIINNITYSOSA ETEEN PITKÄ	FASTENER, FRONT	4	4	4	4
29	22193	KIINNITYSOSA TAAKSE	FASTENER, REAR	8	8	8	8
30	B5R1F4024	ALUSLAATTA M24 DIN125A ZN	WASHER	8	8	8	8
31	32599	REAKTIOTANKO	REACTIONBAR	2	2	2	2
32	D56044	HYD.SYL.NTS4-50/30*200-2B25/3/	CYLINDER	2	2	2	2
33	32597	KIINNITYSOSA TAAKSE	FASTENER, REAR	4	4	4	4
34	18115	KAARI VIISARILLE	CURVE	1	1	1	1
35	18109	VIISARI MUOKKAIMILLE	POINTER	1	1	1	1
36	A0C151514	6-RUUVI M12X35 8.8 DIN933 ZN	SCREW	2	2	2	2
37	A0L201524	6-RUUVI M20X60 8.8 DIN933 ZN	SCREW	6	4	6	4
38	B5L173024	ALUSLAATTA M20 DIN125A ZN	WASHER	6	14	6	14
39	AGL113014	6-MUTTERI II M20 DIN985-8 ZN	NUT	6	5	6	5
40	17743	VÄLIHOLKKI	BUSHING		2		2
41	17657	VÄLIHOLKKI SÄÄTÖTANKOIHIN	BUSHING		1		1
42	A0L7L1514	6-RUUVI M20X220 931 ZN	SCREW		1		1
43	D14441	HYD.LETKU SYLINT.L1180 3-14441	HOSE	4	4	4	4
44	D15312	HYD.LETKU SYLINT.L4600 3-15312	HOSE	2	2	2	2
45	A0C3L1514	6-RUUVI M12X110 8.8 DIN 931ZN	SCREW			24	32
46	18425	JOUSEN KIINNITIN	SPRING HOLDER			24	32
47	B5C0M2514	JOUSIALUSL.M12 DIN127B ZN	SPRING WASEHR			24	32
48	18426	LEVY JOUSENKIINNITTIMEEN	PLATE			24	32
49	D30000480	LANN.VANT.JOUSI M-83 /1.101159	SPRING			24	32
50	A0A1AG511	KÄRKILAPON LUKKOR M10*45 MUS	SCREW			24	32
51	D30000520	LANN VANT KÄRKI M-83 TEK-22	HEAD			24	32
52	B5A0H2214	JOUSIALUSL.M10 DIN127B ZN	SPRING WASHER			24	32
53	AGA111014	6-MUTTERI M10 DIN934-8 ZN	NUT			24	32

6.4KIEKKOMUOKKAIN MD DISC CULTIVATOR MD

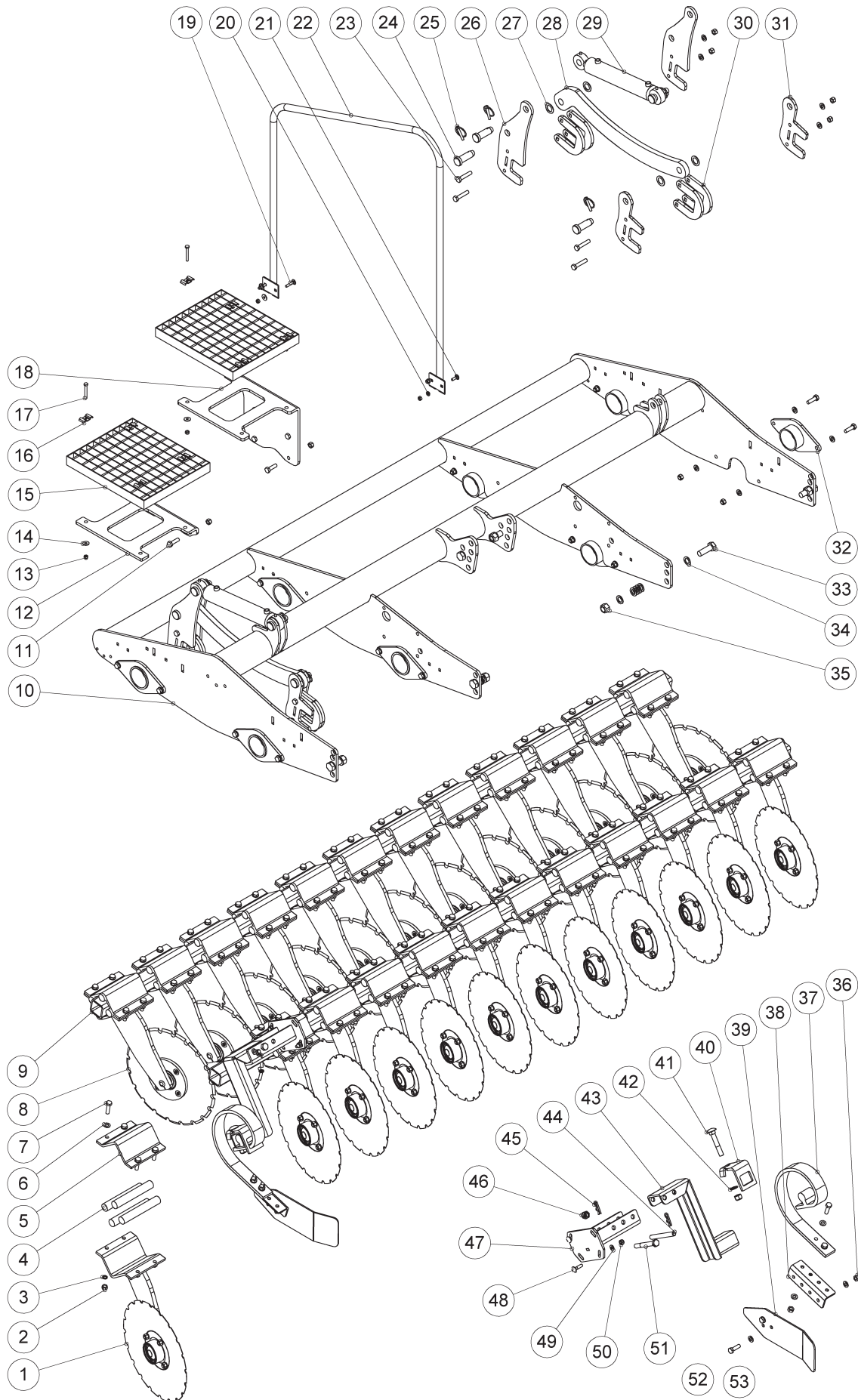

A GOOD WAY TO WORK HARD

OSA PART	KOODI CODE	NIMITYS	DESCRIPTION	MD300	MD400
1	22934	MUOKKARIKIEKKO TAKIMM.	CULTIVATOR DISC	12	16
2	AGC113014	6-MUTTERI II M12 DIN985-8 ZN	NUT	129	157
3	B5C0M2514	JOUSIALUSL.M12 DIN127B ZN	SPRING WASHER	101	128
4	22307	KUMIPATUKKA	RUBBER STICK	96	128
5	22197	KIINNITIN MAALATTU	HOLDER	24	32
6	B5C0R2024	ALUSLAATTA M12 DIN125A ZN	WASHER	154	184
7	A0C1F1024	6-RUUVI M12X45 8.8 DIN933 ZN	SCREW	96	128
8	22935	MUOKKARIKIEKKO ETUMM.	CULTIVATOR DISC	12	16
9	17284	PALKKI RUNKOON	BAR	2	
	18073	KIINNITYSPALKKI 4000	BAR		2
10	31675	KUMIMUOKKAIMEN RUNKO 3M HITS.	FRAME	1	
	33044	KUMIMUOKKAIMEN RUNKO 4M HITS.	FRAME		1
11	A0C1A1014	6-RUUVI M12X40 8.8 DIN933 ZN	SCREW	29	29
12	32606	ALA-ASTIMEN PETI	STEP COUNTERPART	1	1
13	AG8113014	6-MUTTERI II M 8 DIN985-8 ZN	NUT	12	12
14	B580N1524	KORILAATTA M 8 DIN9021B ZN	WASHER	10	10
15	32605	TASORITILÄ LATALLE	GRILL	2	2
16	31175	KIINNIKE	HOLDER	8	8
17	A05960	6-RUUVI M8X60 8.8 DIN 931 ZN	SCREW	8	8
18	32607	TOISEN AKELMAN PETI	STEP COUNTERPART	1	1
19	A081A3014	LUKKOR. M8X40 4.6 DIN 603 ZN	SCREW	2	2
20	B580H1624	ALUSLAATTA M 8 DIN125A ZN	WASHER	2	2
21	A080S3014	LUKKOR. M8X25 4.6 DIN 603 ZN	SCREW	2	2
22	22308	KAIDE	HANDRAIL	1	1
23	A09765	6-RUUVI M12X70 10.9 DIN931ZNC	SCREW	8	8
24	D14446	SYLINTERIN TAPPI 14446	PIVOT	8	8
25	BE8600002	RENGAS-SOKKA 8X45 L=040 ZN	LINCHPIN	8	8
26	22786	KIINNITYSOSA ETEEN PITKÄ	FASTENER, FRONT	4	4
27	33239	ALUSLEVY 26/40 X 2	WASHER	8	8
28	32608	REAKTIOLEVY	REACTION PLATE	2	2
29	D56044	HYD.SYL.NTS4-50/30*200-2B25/3/	CYLINDER	2	2
30	22193	KIINNITYSOSA TAAKSE	FASTENER, REAR	8	8
31	22771	KIINNITYSOSA ETEEN	FASTENER, FRONT	4	4
32	22189	TUKILAAKERI	BEARING	8	8
33	A0L201524	6-RUUVI M20X60 8.8 DIN933 ZN	SCREW	6	6
34	B5L173024	ALUSLAATTA M20 DIN125A ZN	WASHER	20	20
35	AGL113014	6-MUTTERI II M20 DIN985-8 ZN	NUT	6	6
36	AGC111014	6-MUTTERI M12 DIN934-8 ZN	NUT	8	8
37	33498	JOUSI SMD ETULATA	SPRING	2	2
38	33625	KIINNITYSOSA SUISTAJAAN	FASTENER	2	2
39	33626	LEVY SUISTAJAAN	PLATE	2	2
40	33521	JOUSEN KIINNITIN SMD ETULATA	SPRING HOLDER	2	2
41	A0G401513	6-RUUVI M16X110 8.8 DIN931ZN	SCREW	2	2
42	B5G102524	ALUSLAATTA M16 DIN125A ZN	WASHER	2	2
43	33546	VARSII HITS.	ARM	2	2
44	44064	SARANA TAPPI	PIVOT	2	2
45	BD3011404	NEULASOKKA 4Mm DIN11024 ZN	COTTER PIN	4	4
46	AGG113014	6-MUTTERI II M16 DIN985-8 ZN	NUT	2	2
47	33543	RUNKOKAPPALE	FRAME	2	2
48	A0A1A3014	LUKKOR.M10X40 4.6 DIN 603 ZN	SCREW	4	4
49	B5A0MB024	ALUSLAATTA M10 DIN125A ZN	WASHER	4	4
50	AGA113014	6-MUTTERI II M10 DIN985-8 ZN	NUT	4	4
51	A0G401514	6-RUUVI M16X120 8.8 DIN931ZN	SCREW	2	2
52	D14441	HYD.LETKU SYLINT.L1180 3-14441	HOSE	4	4
53	D15312	HYD.LETKU SYLINT.L4600 3-15312	HOSE	2	2

6.4.1 KIEKKOMUOKKAIN
DISC CULTIVATOR

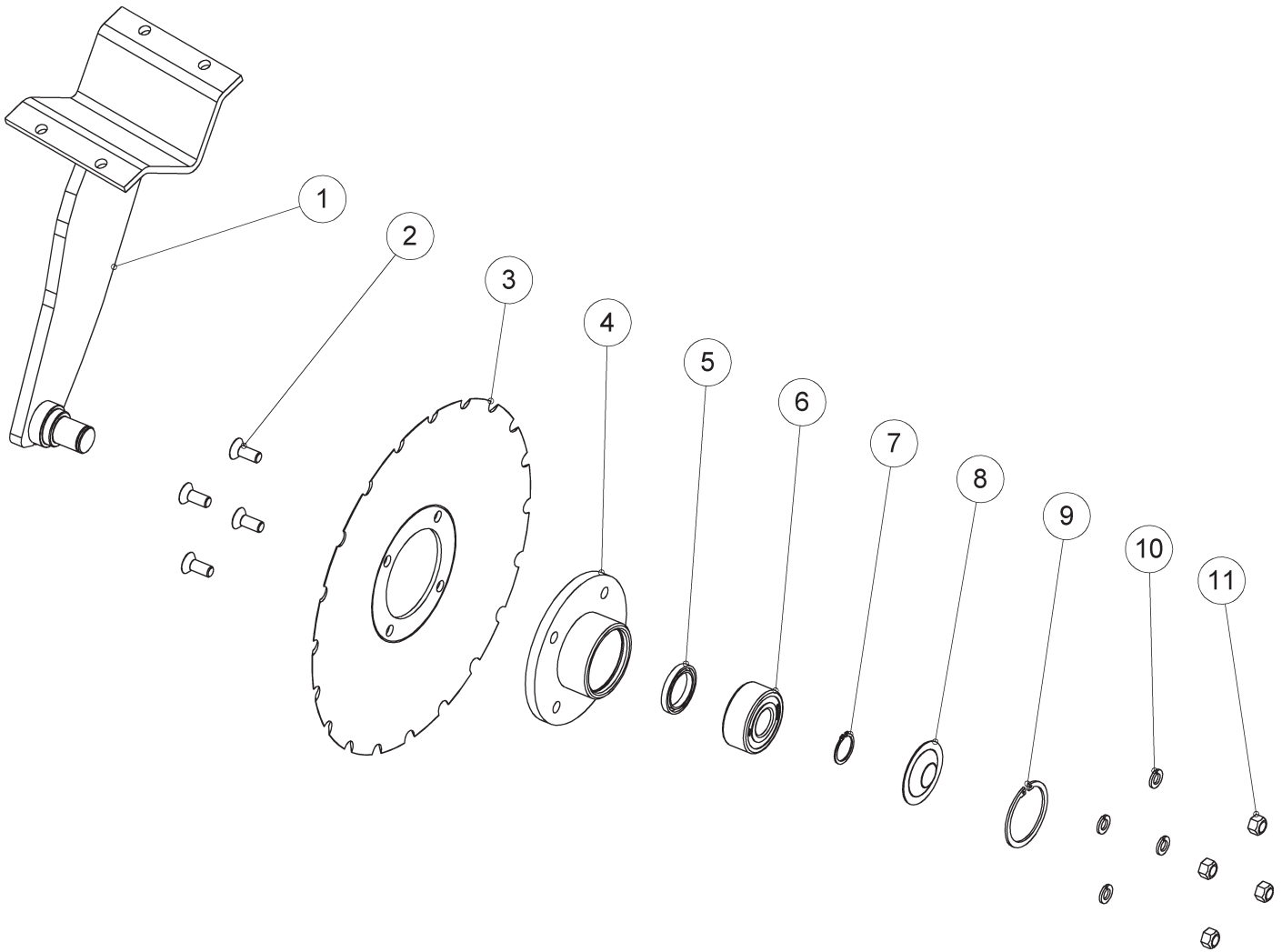

A GOOD WAY TO WORK HARD

OSA PART	KOODI CODE	NIMITYS	DESCRIPTION	ETU/ FRONT	TAKA/ REAR
1	22987	VARSI HITS. ETUMMAINEN	ARM,FRONT	1	
	22986	VARSI HITS. TAKIMMAINEN	ARM, REAR		1
2	A0C0T4524	6-KOLOR.UPP.M12X30 10.9 DIN799	SCREW	4	4
3	D17250	HAMMAST.KIEKKO KUPERA 3-17250	DISC	1	1
4	21096	NAPA HITS. JA KONEIST.	HUB	1	1
5	CNA40557	DIN_3760-A40x55x7 STEFA	SHAFT SEAL	1	1
6	CE33062RSSKF	2-RIV. VIISTOKUULALAAK. 33062R	BEARING	1	1
7	BH1011L11	SEGER-RENG AKS 30X1.5 471	CIRCLIP	1	1
8	21095	SUOJALEVY	COVER PLATE	1	1
9	BH2C21L14	SEGER-RENG REI 72X2.5 472	CIRCLIP	1	1
10	B5C0M2514	JOUSIALUSL.M12 DIN127B ZN	SPRING WASHER	4	4
11	AGC113014	6-MUTTERI II M12 DIN985-8 ZN	NUT	4	4
	22935	MUOKKAINKIEKKO ETU	CULTIVATOR DISC, FRONT		
	22934	MUOKKAINKIEKKO TAKA	CULTIVATOR DISC, REAR		

6.5 RIVIMERKITSIN SMD TRACKMARKER SMD

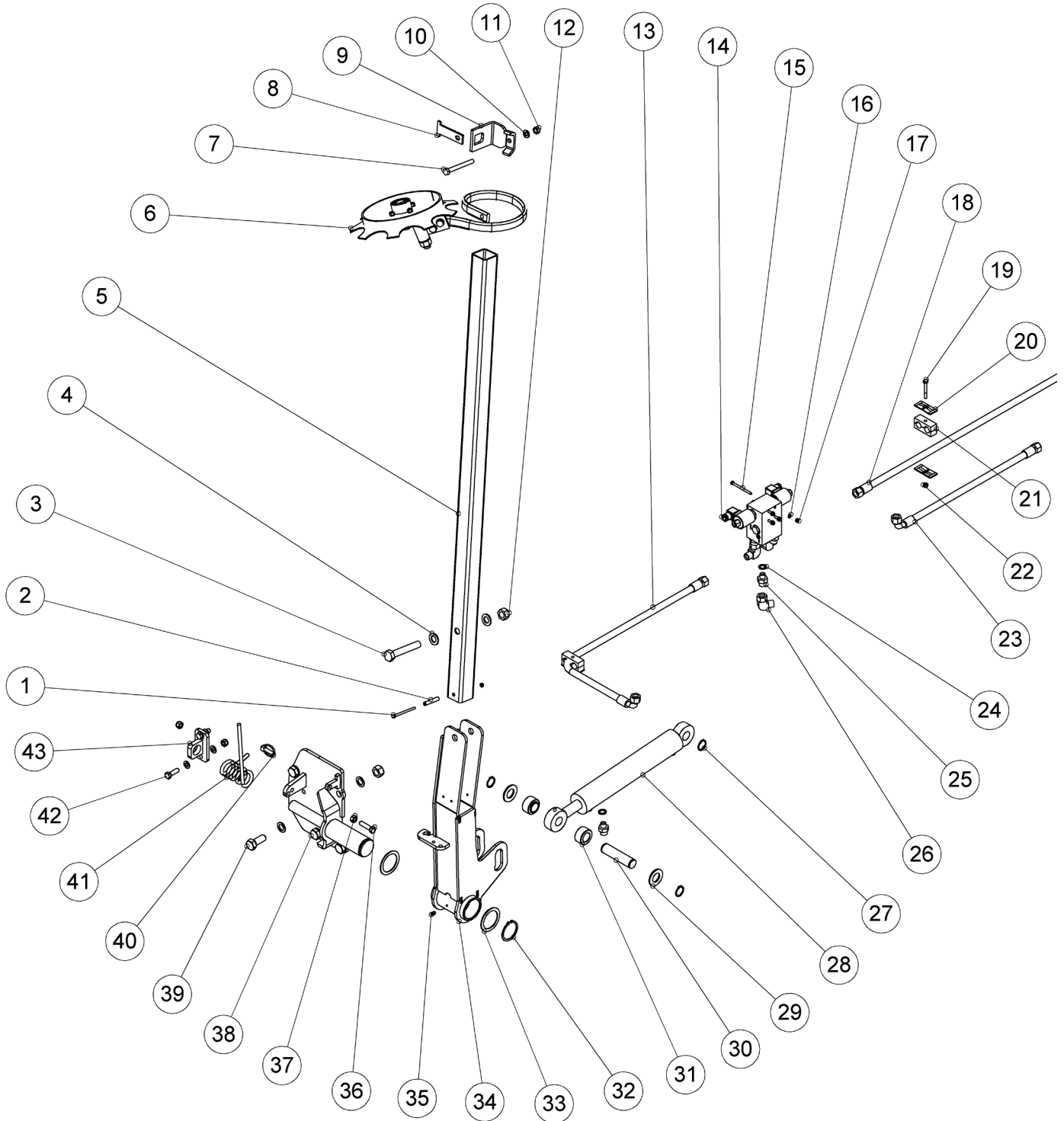

OSA PART	KOODI CODE	NIMITYS	DESCRIPTION	SMD300 SMD400		SMD300 SMD400		SMD300 SMD400		SMD300 SMD400	
				HYTAR	HYTAR	HYTAR	HYTAR	VAIHTO/ SHIFT	VAIHTO/ SHIFT		
1	A062A1114	6-RUUVI M6X90 8.8 DIN931 ZNC	SCREW	2	2	2	2	2	2	2	2
2	B8A200004	JOUSISOKKA 10X60 DIN1481 ZNC	TUBULAR PIN	2	2	2	2	2	2	2	2
3	A13929	6-RUUVI M20x125 8.8 DIN960 ZN	SCREW	2	2	2	2	2	2	2	2
4	B5L173024	ALUSLAATTA M20 DIN125A ZN	WASHER	20	20	20	20	20	20	20	20
5	33001	YLÄVARSIPUTKI 3000	BAR	2	2	2	2	2	2	2	2
6	32617	YLÄVARSIPUTKI 4000	BAR	2	2	2	2	2	2	2	2
7	32451	RIVIMERKKARINPÄÄ OIKEA KP	MARKER DISC, RIGHT	1	1	1	1	1	1	1	1
8	32449	RIVIMERKKARINPÄÄ VASEN KP	MARKER DISC, LEFT	1	1	1	1	1	1	1	1
9	A0C3L1514	6-RUUVI M12X110 8.8 DIN 931Zn	SCREW	2	2	2	2	2	2	2	2
10	18426	LEVY JOUSENKIINNITTIMEEN	PLATE	2	2	2	2	2	2	2	2
11	18425	JOUSEN KIINNITIN	SPRING HOLDER	2	2	2	2	2	2	2	2
12	B5C0R2024	ALUSLAATTA M12 DIN125A ZN	WASHER	10	10	10	10	10	10	10	10
13	AGC113014	6-MUTTERI II M12 DIN985-8 ZN	NUT	8	8	8	8	8	8	8	8
14	AGL113014	6-MUTTERI II M20 DIN985-8 ZN	NUT	10	10	10	10	10	10	10	10
15	33398	HYDRAULILETKU OIK. RIVIM. 300	HOSE 300 RIGHT	1	1	1	1	1	1	1	1
16	33401	HYDRAULILETKU OIK. RIVIM.400	HOSE 400 RIGHT	1	1	1	1	1	1	1	1
17	33468	LETKU LYHYT VAIHTOVENT. SMD300	HOSE SHIFTVALVE 300	1	1	1	1	1	1	1	1
18	33666	LETKU LYHYT VAIHTOVENT. SMD400	HOSE SHIFTVALVE 400	1	1	1	1	1	1	1	1
19	BF328465KP	VENTTIILIRYHMÄ 2*SV10-28 + FDB	VALVE	1	1	1	1	1	1	1	1
20	D15554A	VENTTIILI 2068-T2752	VALVE	1	1	1	1	1	1	1	1
21	AC688811	VAIHTOVENTTIILI	SHIFTVALVE	4	4	4	4	4	4	4	4
22	A062A1014	6-RUUVI M6X80 8.8 DIN931 ZNC	SCREW	4	4	4	4	4	4	4	4
23	B560E1524	ALUSLAATTA M 6 DIN125A ZN	WASHER	4	4	4	4	4	4	4	4
24	AG6113014	6-MUTTERI II M 6 DIN985-8 ZN	NUT	6	6	6	6	6	6	6	6
25	33399	HYDRAULILETKU VAS. RIVIM. 300	HOSE 300 LEFT	1	1	1	1	1	1	1	1
26	33402	HYDRAULILETKU VAS. RIVIM.400	HOSE 400 LEFT	1	1	1	1	1	1	1	1
27	33469	LETKU PITKÄ VAIHTOVENT. SMD300	HOSE SHIFTVALVE 300	1	1	1	1	1	1	1	1
28	33665	LETKU PITKÄ VAIHTOVENT. SMD400	HOSE SHIFTVALVE 400	1	1	1	1	1	1	1	1
29	A05960	6-RUUVI M8X60 8.8 DIN 931 ZN	SCREW	1	1	1	1	1	1	1	1
30	D6CF3U	PEITELEVY CF3-U	COVER PLATE	4	4	4	4	4	4	4	4
31	D6C322	KAKSOISKIINNIKE CF 322-22	DOUBLE HOLDER	3	3	3	3	3	3	3	3
32	AG8113014	6-MUTTERI II M 8 DIN985-8 ZN	NUT	1	1	1	1	1	1	1	1
33	D41412	LETKUASENNELMA 1/2 600 3-41412	HOSE	1	1	1	1	1	1	1	1
34	22322	RIVIMERKKARIN LETKU TRAKTORIIN	HOSE	1	1	1	1	1	1	1	1
35	133300P	USIT-TIIVISTE 217-06 3/8	SEAL	6	6	6	6	6	6	6	6
36	134460P	KAKSOISNIPPA 202-06-08 3/8-1/2	DOUBLE NIPPLE	6	6	6	6	6	6	6	6
37	D12383	KULMANIPPA 704-08 T	ANGLE NIPPLE	3	3	3	3	3	3	3	3
38	BH1011L11	SEGER-RENG AKS 30X1.5 471	CIRCLIP	6	6	6	6	6	6	6	6
39	33383	HYDRAULISYLINTERI SÄÄDETTÄVÄ	CYLINDER	2	2	2	2	2	2	2	2
40	B61850	ALUSLAATTA M30 DIN125A ZNC	WASHER	4	4	4	4	4	4	4	4
41	31701	AKSELI	SHAFT	2	2	2	2	2	2	2	2
42	31703	HOLKKI	BUSHING	4	4	4	4	4	4	4	4

OSA PART	KOODI CODE	NIMITYS	DESCRIPTION	SMD300	SMD400	SMD300	SMD400	SMD300	SMD400	SMD300	SMD400	SMD300	SMD400	SHIFT
32	BH2012F24	SEGER-RENG AKS 60X2 471	CIRCLIP	2	2	2	2	2	2	2	2	2	2	2
33	21050	VÄLIPRIKKA 80/61/2	WASHER	4	4	4	4	4	4	4	4	4	4	4
34	33379	VARSİ HİTS. OİK.	ARM, RIGHT	1	1	1	1	1	1	1	1	1	1	1
	33231	VARSİ HİTS. VAS.	ARM, LEFT	1	1	1	1	1	1	1	1	1	1	1
35	BJ6500000	RASYANIPPA M 8*1.25 N:O 507	GREASE NIPPLE	2	2	2	2	2	2	2	2	2	2	2
36	A0C1L1524	6-RUUVI M12X50 8.8 DIN933ZN	SCREW	2	2	2	2	2	2	2	2	2	2	2
37	AGC11014	6-MUTTERI M12 DIN934-8 ZN	NUT	2	2	2	2	2	2	2	2	2	2	2
38	33377	SARANA HİTS. OİK.	PIVOT RIGHT	1	1	1	1	1	1	1	1	1	1	1
	33229	SARANA HİTS. VAS.	PIVOT LEFT	1	1	1	1	1	1	1	1	1	1	1
39	A13650	6-RUUVI M20X50 8.8 DIN933 ZN	SCREW	8	8	8	8	8	8	8	8	8	8	8
40	BEC000002	RENGAS-SOKKA 10X40 L=40 ZN	LINCHPIN	2	2	2	2	2	2	2	2	2	2	2
41	D14154A	JOUSI 90 AST.(VASEN) 3-15506	SPRING	1	1	1	1	1	1	1	1	1	1	1

6.6 RIVIMERKITSIMEN PÄÄ TRACKMARKER DISC

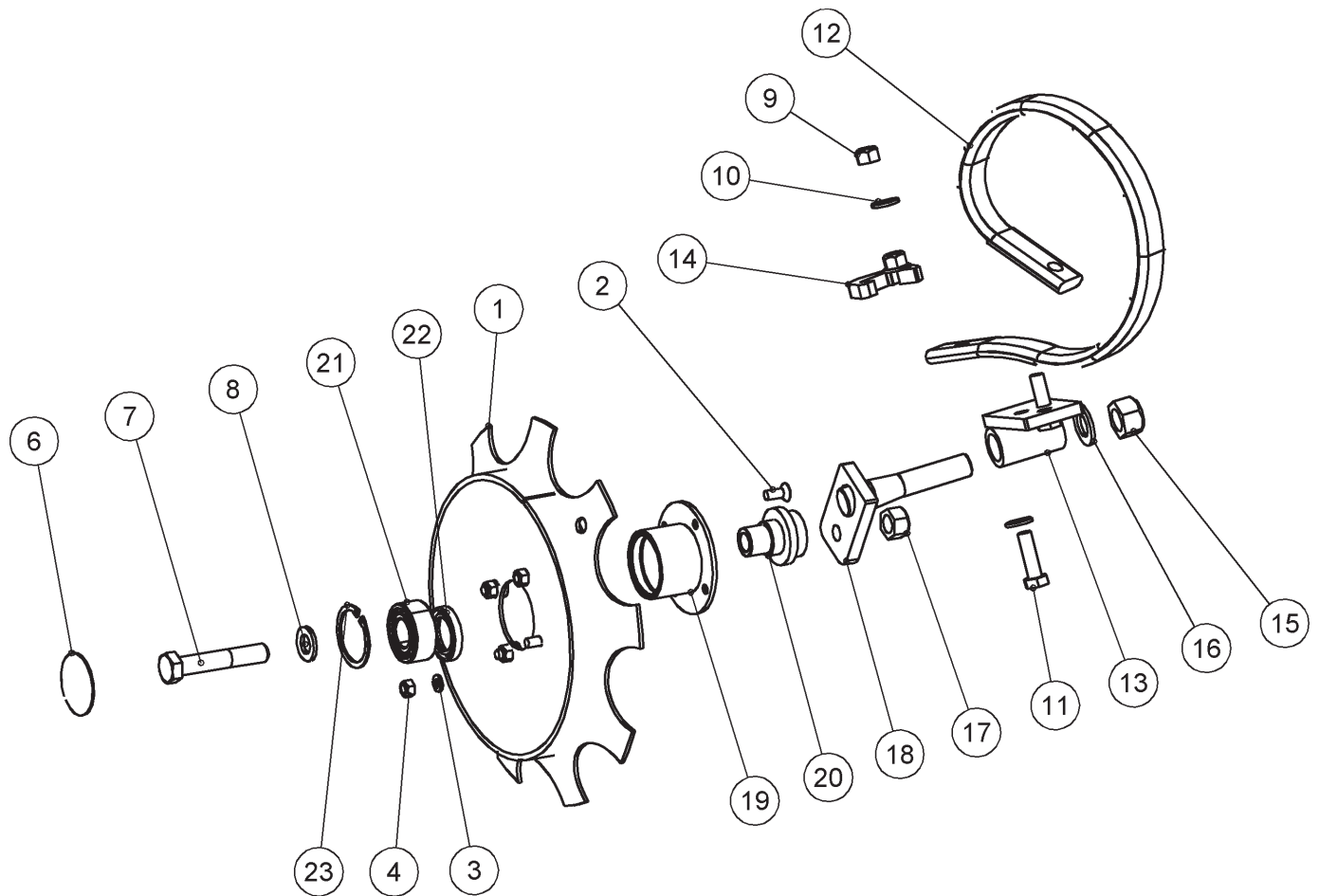

OSA PART	KOODI CODE	NIMITYS	DESCRIPTION	KPL/PCS
1	32446	KIEKKO HITS.	DISC	1
2	A080L4511	6-KOLOR. UPP. M8X20 10.9Din7991	SCREW	4
3	B580E2014	JOUSIALUSLAATTA.M 8 Din127B Zn	WASHER	4
4	AG8111014	6-MUTTERI M 8 Din934-8 Zn	NUT	4
6	21108	SUOJAKUPPI	COVER	1
7	A0G301512	6-RUUVI M16X90 8.8 Din931 Zn	SCREW	1
8	B5G102524	ALUSLAATTA M16 Din125A Zn	WASHER	1
9	AGC113014	6-MUTTERI II M12 Din985-8 Zn	NUT	2
10	B5C0R2024	ALUSLAATTA M12 Din125A Zn	WASHER	4
11	A0C1A1014	6-RUUVI M12X40 8.8 Din933 Zn	SCREW	2
12	D30000481	JOUSI LANN. VANT. M-87 22897S	SPRING	1
13	21039	SÄÄTÖPALA HITS.	ADJUSTMENT PIECE	1
14	21178	LUKITUSPALA	LOCK	1
15	AGL113014	6-MUTTERI II M20 Din985-8 Zn	NUT	1
16	B5L173024	ALUSLAATTA M20 Din125A Zn	WASHER	1
17	AGG113014	6-MUTTERI II M16 Din985-8 Zn	NUT	1
18	22410	SÄÄTÖLEVY HITS. M16	PLATE	1
19	36191	VANTAAN NAPA	HUB	1
20	36189	PAIKOITUSHOLKKI	BUSHING	1
21	CE3205	VIISTOKUULALAAKERI 3205A 2 Rs	BEARING	1
22	CNA304770	STEFA Din 3760 A30*47*7	SHAFT SEAL	1
23	BH1N20021	SEGER RENG. Rei 52X2 472	CIRCLIP	1
	32451	RIVIMERKKARINPÄÄ OIKEA KOOTTU	MARKER DISC, RIGHT	
	32449	RIVIMERKKARINPÄÄ VASEN KOOTTU	MARKER DISC, LEFT	

6.7 PIENSIEMENLAITE SMD, SÄILIÖ SMALL SEED DEVICE SMD, HOPPER

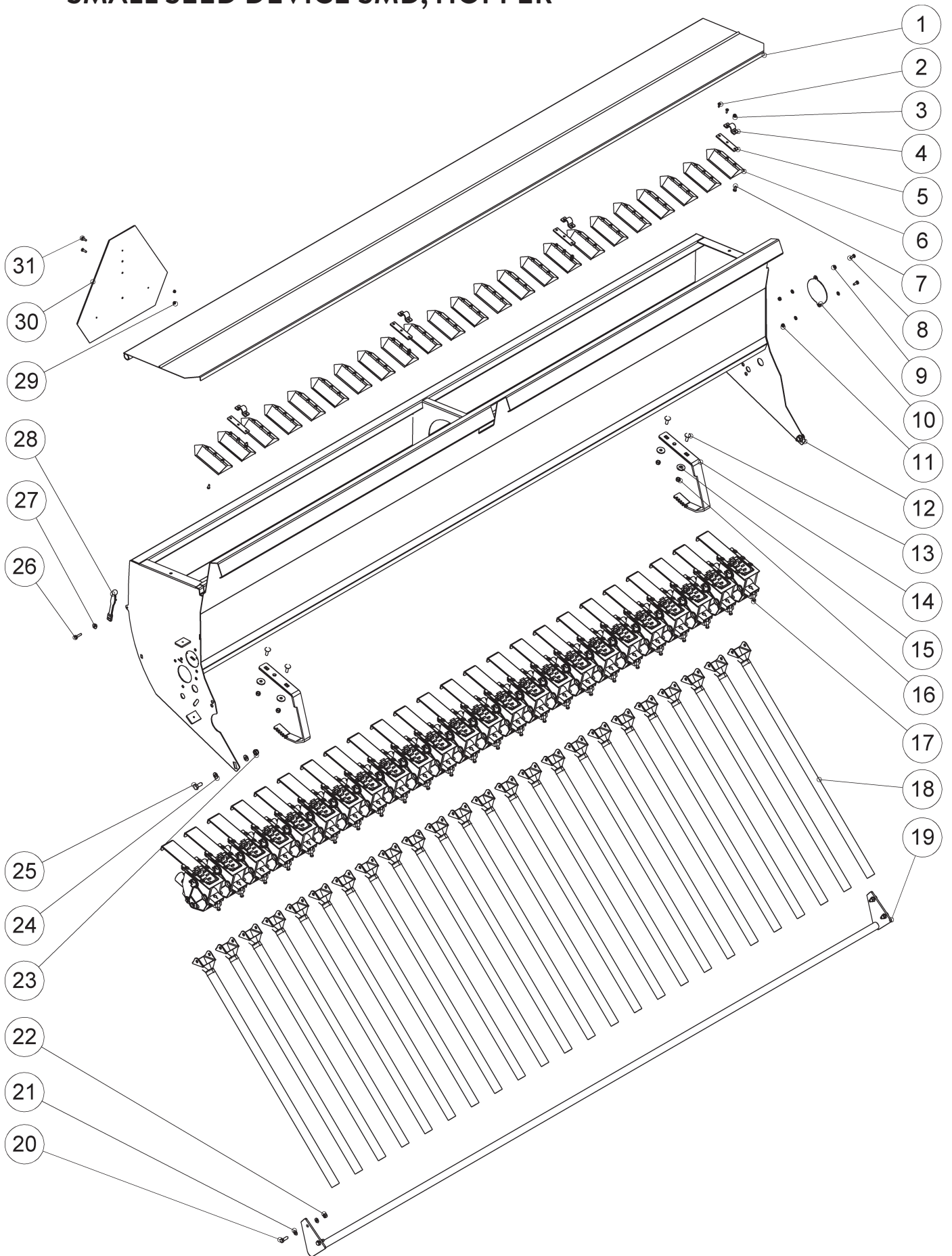

A GOOD WAY TO WORK HARD

OSA PART	KOODI CODE	NIMITYS	DESCRIPTION	SMD300	SMD400
1	33326	PSL PEITE 300	LID	1	
	33343	PSL PEITE 400	LID		1
2	A670G9824	X-LEVYR.4.8X16 A2 DIN7981C POZ	SCREW	31	41
3	A50451	6-MUTTERI II M6 DIN985 AISI	NUT	7	8
4	160828	LAAKERIN YLEMPI PUOLIKAS	BEARING, UPPER	4	5
5	20861	LAAKERIN ALEMPI PUOLIKAS	BEARING, LOWER	4	5
6	D17941	MAESTRON POHJAKARTIO 17941	BOTTOM CONE	23	31
7	A02195	6-RUUVI M6X16 A2 DIN 933 AISI	SCREW	4	5
8	A060G1024	6-RUUVI M6X16 8.8 DIN 933 ZN	SCREW	2	2
9	B560E1524	ALUSLAATTA M 6 DIN125A ZN	WASHER	5	5
10	21204	LISÄSUOJA SEKOITINAKSELILLE	COVER PLATE	1	1
11	AG6113014	6-MUTTERI II M 6 DIN985-8 ZN	NUT	4	4
12	33295	PSL SÄILIÖ HITS. 300	HOPPER	1	
	33342	PSL SÄILIÖ HITS. 400	HOPPER		1
13	A080S3014	LUKKOR. M8X25 4.6 DIN 603 ZN	SCREW	5	5
14	33325	ASENTOLEVY PSL HARMAA	POSITION PLATE	2	2
15	B580V1544	KORILAATTA M 8 DIN440R ZN	WASHER	4	4
16	AG8113014	6-MUTTERI II M 8 DIN985-8 ZN	NUT	2	2
17	17580	SIEMENPUOLEN SYÖTTÖKOTELO	FEEDER CASE	24	32
18	32458	SYÖTTÖPUTKI PSL KOOTTU	FEEDER TUBE	24	32
19	18807	SYÖTTÖPUTKIEN KANNATIN	FEEDER TUBE HOLDER	1	
	18324	SYÖTTÖPUTKIEN KANNATIN 4000	FEEDER TUBE HOLDER		1
20	A0435	6-RUUVI M6X25 A2 DIN933 AISI	SCREW	2	2
21	B560N1525	KORILAATTA M6 A2 DIN9021 AISI	WASHER	2	2
22	AG8113014	6-MUTTERI II M 8 DIN985-8 ZN	NUT	2	2
23	A50251	6-MUTTERI II M5 A2 DIN985 AISI	NUT	2	2
24	B5A0MB024	ALUSLAATTA M10 DIN125A ZN	WASHER	1	1
25	A01050	URARUUVI M5X16 A2 DIN 7985 POZ	SCREW	2	2
26	A080S1514	6-RUUVI M8X25 8.8 DIN933 ZN	SCREW	4	4
27	B580H1624	ALUSLAATTA M 8 DIN125A ZN	WASHER	8	8
28	E74337	KUMISALPA ROSENLEW RALLIHAKA	RUBBER LATCH	4	4
29	AGA113014	6-MUTTERI II M10 DIN985-8 ZN	NUT	2	2
30	D50000387	LGF HIT.AJON.KOLMIO MUOVINEN	SMV STICKER	4	4
31	A0A0S1524	6-RUUVI M10X25 8.8 DIN933 ZN	SCREW	2	2

6.8PIENSIEMENLAITE SMD, KONEISTO
SMALL SEED DEVICE SMD, GEAR

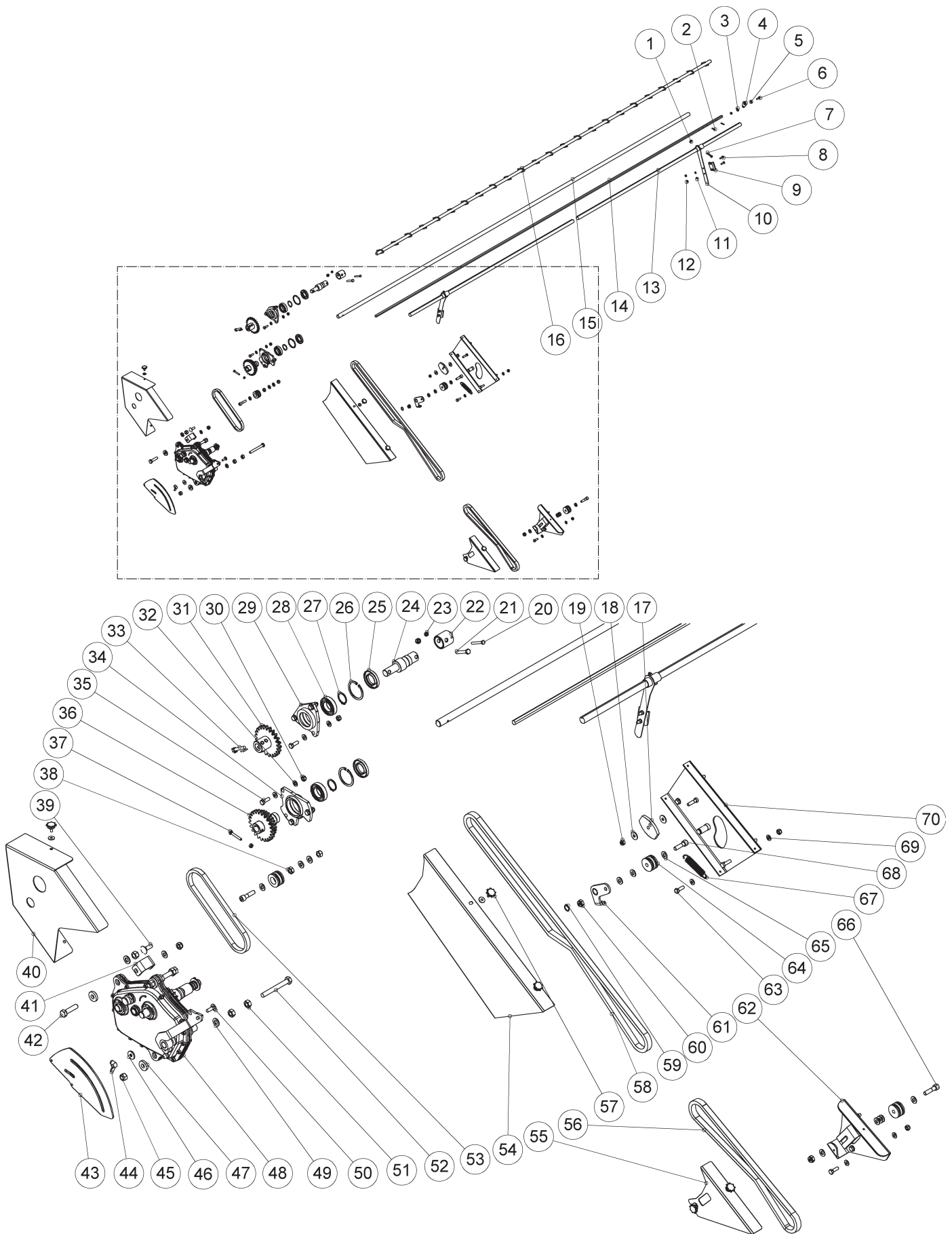

A GOOD WAY TO WORK HARD

OSA PART	KOODI CODE	NIMITYS	DESCRIPTION	SMD300	SMD400
1	AG6113014	6-MUTTERI II M 6 DIN985-8 ZN	NUT	3	3
2	B840S0001	JOUSISOKKA 4X24 DIN1481 ZNC	TUBULAR PIN	2	2
3	B560N1524	KORILAATTA M 6 DIN9021 ZN	WASHER	9	9
4	33603	LUKITUSLEVY	LOCK PLATE	1	1
5	B560E1524	ALUSLAATTA M 6 DIN125A ZN	WASHER	1	1
6	A060L1524	6-RUUVI M6X20 8.8 DIN 933 ZN	SCREW	1	1
7	A06151514	6-RUUVI M6X35 8.8 DIN 933 ZN	SCREW	2	2
8	A02100	URARUUVI M6X16 A2 DIN 7985 POZ	SCREW	4	4
9	161505	LUKITSIN SÄÄTÖVIPUUN	LOCK	2	2
10	17671	VIPU HITS.	LEVER	2	2
11	B560B1615	JOUSIALUSL. M6 DIN127B A2 AISI	SPRING WASHER	4	4
12	A50452	6-MUTTERI M6 A2 DIN934 AISI	NUT	4	4
13	17563	POHJÄLÄPÄN AKSELI	BOTTOM FLAP SHAFT	2	
	33192	POHJÄLÄPÄN AKSELI PSL 400	BOTTOM FLAP SHAFT		2
14	17564	PIKKULÄPÄN AKSELI	LITTLE FLAP SHAFT	1	
	18136	PIKKULÄPÄN AKSELI 4000	LITTLE FLAP SHAFT		1
15	32553	PSL SYÖTTÖAKSELI 2014	FEED SHAFT	1	
	31937	SYÖTTÖAKSELI SIEM.PUOLI	FEED SHAFT		1
16	32554	SEKOITINAKSELI HITSATTU	MIXER SHAFT	1	
	33188	SEKOITINAKSELI HITS. PSL 400	MIXER SHAFT		1
17	130440	KETJUNKIRISTÄJÄ	CHAIN TIGHTEN	1	1
18	B580N1524	KORILAATTA M 8 DIN9021B ZN	WASHER	2	2
19	AG8113014	6-MUTTERI II M 8 DIN985-8 ZN	NUT	11	11
20	A03556	6-RUUVI M6X50 A2 DIN933 AISI	SCREW	1	1
21	A081L1821	6-RUUVI M8X50 A2 DIN933 AISI	SCREW	1	1
22	21129	HOLKKI SEK.AKSELIIN	BUSHING	1	1
23	A50451	6-MUTTERI II M6 DIN985 AISI	NUT	1	1
24	33315	HAMMASP. NAPA	PINION	1	1
25	D49009	STEFA 30*55*7 CRW1R	SHAFT SEAL	2	2
26	BH1S1S0J1	SEGER-RENG REI 55X2 472	CIRCLIP	2	2
27	BH1011L11	SEGER-RENG AKS 30X1.5 471	CIRCLIP	2	2
28	CE60062RS	KUULALAAKERI 6006 2 RS	BEARING	2	2
29	33317	LAAKERIPESÄ HITS.	HUB	1	1
30	A50710	6-MUTTERI II M8 A2 DIN985 AISI	NUT	7	7
31	33334	HAMMASPYÖRÄ HITS. SEK.AKS.	PINION	1	1
32	B60649	ALUSLAATTA M 8 DIN125A A2 AISI	WASHER	12	12
33	BEC000003	RENGASSOKKA 5080451	LINCHPIN	1	1
34	17185	LAAKERIPESÄ VIISTETTY	HUB	1	1
35	A04750	6-RUUVI M8X25 A2-80 DIN933 AIS	SCREW	6	6
36	33298	KETJUP.HITS.PSL	PINION	1	1
37	A061A1524	6-RUUVI M6X40 8.8 DIN 933 ZN	SCREW	2	2
38	AGA111014	6-MUTTERI M10 DIN934-8 ZN	NUT	1	1
39	A07320	LUKKOR.M10X30 8.8 DIN 603 ZN	SCREW	1	1
40	33327	KETJUSUOJA PSL	CHAIN COVER	1	1
41	33320	KIINNITYSLATTA VAIHDEL.	HOLDER FOR TRANS.	1	1
42	A0C1L1524	6-RUUVI M12X50 8.8 DIN933ZN	SCREW	1	1
43	32565	ASTEIKKOKAARI PSL 2014	CURVE	1	1
44	D30142	SIIPIVÄÄNNIN + TULPPA 80105	KNOB	1	1
45	AGC113014	6-MUTTERI II M12 DIN985-8 ZN	NUT	3	3
46	19848	KUMIPRIKKA 9*25	WASHER	1	1
47	B1213306	ALUSLAATTA M12 13/30/6 DIN7349	WASHER	3	3
48	32585	VAIHDELAATIKKO KOOTTU PSL	GEARBOX	1	1
49	B5COR2024	ALUSLAATTA M12 DIN125A ZN	WASHER	3	3
50	A080S3014	LUKKOR. M8X25 4.6 DIN 603 ZN	SCREW	1	1
51	AGC111014	6-MUTTERI M12 DIN934-8 ZN	NUT	4	4
52	A0C3A1024	6-RUUVI M12X100 8.8 DIN933ZNC	SCREW	2	2
53	33319	RULLAKETJU PSL	CHAIN	1	1
54	32560	SUOJA PSL ISO SÄILIÖ	COVER	1	1
55	33332	KETJUSUOJA PSL ECO	CHAIN COVER	1	1
56	33335	RULLAKETJU PSL ECO	CHAIN	1	1
57	A01560	SORMIRUUVI M*6X10 /32799900	SCREW	8	8
58	32457	RULLAKETJU 1/2" 137 LENKKIÄ +	CHAIN	1	1
59	BH0H11L16	SEGER-RENG AKS 16X1 471	CIRCLIP	1	1
60	AGA113014	6-MUTTERI II M10 DIN985-8 ZN	NUT	4	4
61	19081	KETJUNKIRISTÄJÄ HITS	CHAIN TIGHTEN	1	1
62	33331	KIINNITYSLEVY HITS.	FASTENER PLATE	1	1
63	A080S1514	6-RUUVI M8X25 8.8 DIN933 ZN	SCREW	11	11
64	137224	RULLA KETJUNKIRISTÄJÄÄN	ROLL	3	3
65	B5A0MB024	ALUSLAATTA M10 DIN125A ZN	WASHER	8	8
66	A0A1A4524	6-KOLOR.M10X40 8.8 DIN912 ZN	SCREW	2	2
67	D14105	VETOJOUSI 2.25*18*90 SINK9208S	DRAW SPRING	1	1
68	A0A1B4524	6-KOLOR. M10X35 8.8 DIN 912 ZN	SCREW	1	1
69	B580H1624	ALUSLAATTA M 8 DIN125A ZN	WASHER	22	22
70	32588	SUOJAN TAKALEVY HITS	COVER REAR	1	1

6.9 SIEMENSEULAT SMD SIEVES FOR SEED SMD

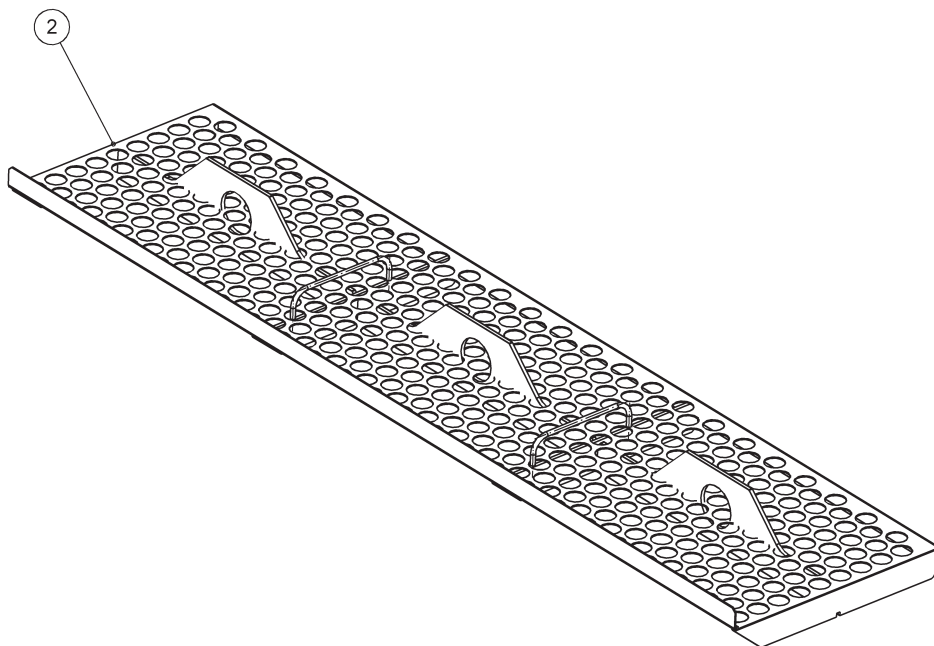
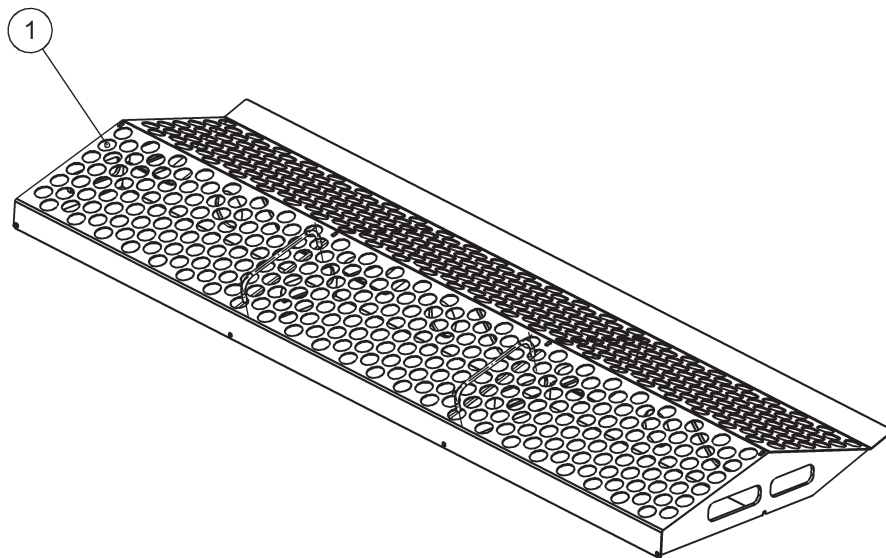

OSA PART	KOODI CODE	NIMITYS	DESCRIPTION	LANN. ERI/ FERT. DIFF	LANN. SAMA/ FERT. SAME
1	33529	SIEMENSEULA HITS. 300 ERIRIVI	SIEVE, SEED	2	
	33563	SIEMENSEULAT SMD 400 ERIRIVI	SIEVE, SEED	2	
2	33548	SIEMENSEULA HITS. 300 SAMARIVI	SIEVE, SEED		2
	33566	SIEMENSEULA HITS. 400 SAMARIVI	SIEVE, SEED		2

6.10 PUOLENKONEEN SULKU HALF CLOSE

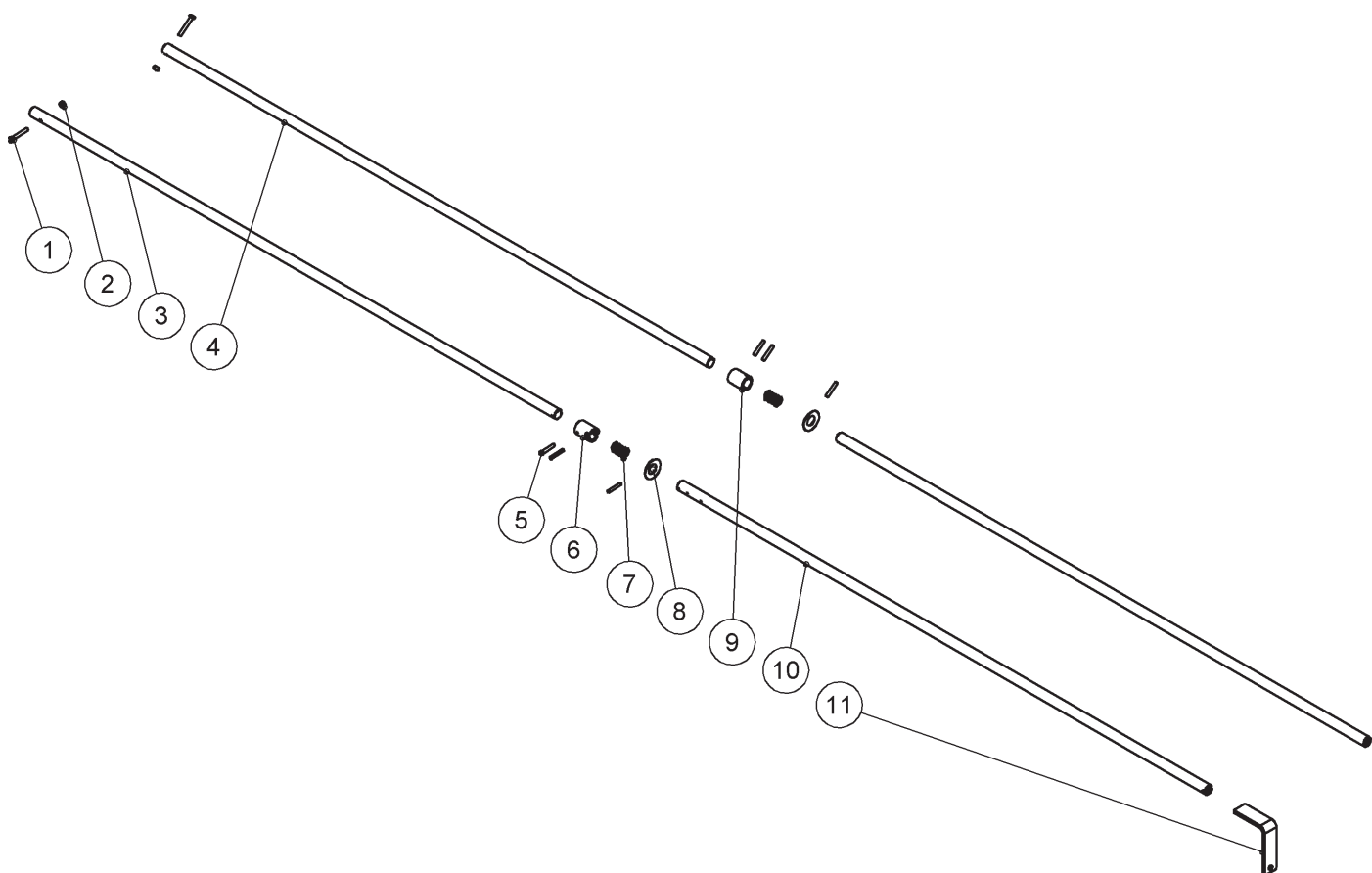

OSA PART	KOODI CODE	NIMITYS	DESCRIPTION	300	400
1	A061A1524	6-RUUVI M6X40 8.8 DIN 933 ZN	SCREW	2	2
2	AG6113014	6-MUTTERI II M 6 DIN985-8 ZN	NUT	2	2
3	31787	SYÖTTÖAKSELI LP 1	FEED SHAFT, FERT	1	
	33421	SYÖTTÖAKSELI LP 1	FEED SHAFT, FERT		1
4	31788	SYÖTTÖAKSELI SP 1	FEED SHAFT, SEED	1	
	33422	SYÖTTÖAKSELI SP 1	FEED SHAFT, SEED		1
5	B85120001	JOUSISOKKA 5X32 DIN1481 ZNC	TUBULAR PIN	6	6
6	33419	KYTKINHOLKKI LANN.PUOLI	BUSHING	1	1
7	D19671	PURISTUSJOUSI 2*18*30 19671	SPRING	2	2
8	B61472	LAUTASJOUSI 40*20.4*1.5	SPRING	2	2
9	19618	KYTKINHOLKKI	CLUTCH BUSHING	1	1
10	33496	SYÖTTÖAKSELI LP 2	FEED SHAFT, FERT	2	
	33501	SYÖTTÖAKSELI LP 2 400	FEED SHAFT, FERT		2
11	33497	AVAIN PUOLENKONEEN SULKU	KEY FOR HALF CLOSE	1	1

6.11 LISÄOSAT KULJETUSTA VARTEN SMD ACCESSORIES FOR TRANSPORTING SMD

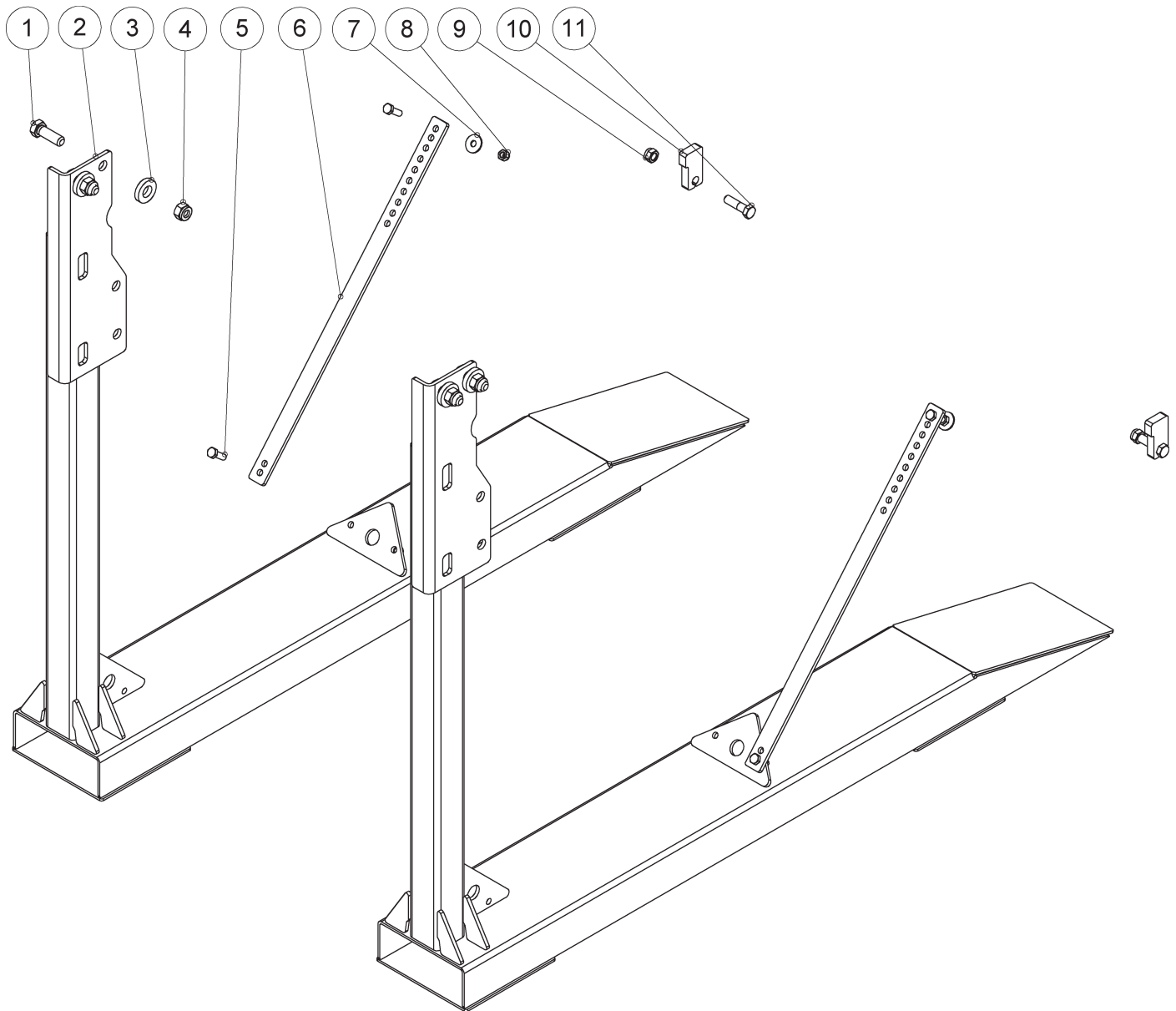

OSA PART	KOODI CODE	NIMITYS	DESCRIPTION	KPL/PCS
1	A0L201524	6-RUUVI M20X60 8.8 DIN933 ZN	SCREW	4
2	33456	KULJETUSJALKA HITS. S JA M	TRANSPORT BASE	2
3	B5R1F4025	ALUSLEVY M24 DIN_7349-25	WASHER	4
4	AGL113014	6-MUTTERI II M20 DIN985-8 ZN	NUT	4
5	A0C1A1014	6-RUUVI M12X40 8.8 DIN933 ZN	SCREW	4
6	33458	LATTA S	PLATE	2
7	B5C0R2124	KORILAATTA M12 DIN9021 ZN	WASHER	2
8	AGC113014	6-MUTTERI II M12 DIN985-8 ZN	NUT	4
9	AGG113014	6-MUTTERI II M16 DIN985-8 ZN	NUT	2
10	33459	TOPPARI TELIIN	STOPPER	2
11	A0G201514	6-RUUVI M16X60 8.8 DIN931 ZN	SCREW	2

Junkkari
Part of the MSK Group

**A GOOD WAY TO
WORK
HARD**