

Junkkari



A GOOD WAY TO WORK SMART

OPERATING MANUAL JUNKKARI S-M-T-D SEED DRILLS

OH000120
2020

SISÄLTÖ

1 DEAR CUSTOMER	5
1.1 SPARE PARTS CATALOGS	5
2 TECHNICAL SPECIFICATIONS	6
3 MACHINE PRESENTATION	7
3.1 S- AND SH-series	7
3.2 M-series	9
3.3 T-SERIES	11
3.4 D-Series	13
4 SAFETY	15
4.1 SYMBOLS of the manual	15
4.2 GENERAL SAFETY INSTRUCTIONS	15
4.2.1 OPERATIONAL LIMITATIONS AND PROHIBITED USES	15
4.2.2 Before using the machine	15
4.2.3 Moving the machine	15
4.2.4 HANDLING THE MACHINE	16
4.2.5 STORING THE MACHINE	16
4.3 Machine-specific safety instructions	17
4.3.1 MOVING THE MACHINE	17
4.3.2 DANGEROUS SITUATIONS	17
4.3.3 HYDRAULICS	17
4.3.4 noise	18
4.4 WARNINGS STICKERS, SAFETY COMPONENTS AND TYPE PLATE	19
4.4.1 Warning stickers	19
4.4.2 safety components of the machine	20
4.4.3 Type plate	20
4.5 warranty terms	21
4.6 Responsibilities	22
4.7 DEcommissioning	22
5 commissioning	23
5.1 opening the transportation package	24
5.1.1 opening the s- and m-series transportation package	24
5.1.2 OPENING THE D-SERIES TRANSPORTATION PACKAGE	25
5.2 INSTALLING THE HARROW	26
5.3 INSTALLING THE TRACKMARKER	27
5.4 INSTALLING THE COVER	27
5.5 INSTALLING THE CONTROL UNIT	28
5.6 REQUIREMENTS SET FOR THE TRACTOR	29
5.7 CONNECTING AND DISCONNECTING THE MACHINE	29
5.7.1 Connecting – without a packer	29
5.7.2 Disconnecting – without a packer	30
5.7.3 Connecting – with a packer	30
5.7.4 Disconnecting – with a packer	30
5.8 CONNECTING HYDRAULIC HOSES AND ELECTRIC CABLES	30
5.8.1 Connecting hydraulic hoses	30
5.8.2 Connecting electric cables	30
6 MACHINE ADJUSTMENT	32
6.1 Hopper wall (Eco and Plus)	32
6.2 PACKER	33

6.3 HEIGHT OF THE MACHINE FRAME	33
6.4 HORIZONTAL MACHINE POSITION	35
6.5 friction wheel	37
6.6 SEEDING DEPTH OF SEED COULTERS IN S-SERIES MACHINES	37
6.6.1 Mechanical adjustment of the coulters pressure	38
6.6.2 Hydraulic adjustment of the coulters pressure	38
6.6.3 Coulters-specific adjustment and seeding depth	38
6.7 WORKING DEPTH OF FERTILISER COULTERS IN S-SERIES MACHINES	39
6.8 SEEDING DEPTH OF SEED COULTERS IN M-SERIES MACHINES	40
6.9 WORKING DEPTH OF FERTILISER COULTERS IN M-SERIES MACHINES	40
6.10 COULTER SIDE PLATE IN S- AND M-SERIES MACHINES	41
6.11 SEEDING DEPTH AND PRESS WHEEL IN D-SERIES MACHINES	41
6.12 TRACKMARKER	43
6.13 following harrow	44
6.13.1 Half lift of the harrow (S- and M-series)	44
6.14 HOPPER ROLL COVER	45
6.15 FEEDING MECHANISM	46
6.15.1 Metering device for seeds and fertiliser	46
6.15.2 cleaning the feed roll	47
6.15.3 Adjusting the bottom flap	47
6.15.4 Switch valve positions	47
6.15.5 Closing hatch	48
7 calibration and defining the seeding volume	49
7.1 CALIBRATION USING A MANUAL VOLUME CONTROL	49
7.2 CALIBRATION USING AN ELECTRONIC VOLUME CONTROL	50
7.3 CALIBRATION BY DRIVING	51
8 tramlines	55
8.1 symmetrical tramlines	57
8.2 asymmetrical tramlines on the left side of the seed drill	57
8.3 ASYMMETRICAL TRAMLINES ON THE RIGHT SIDE OF THE SEED DRILL	58
9 SURFACE AREA METER	59
9.1 Technical specifications	59
9.2 General	59
9.3 USING THE SURFACE AREA METER	59
9.4 changing and resetting values	60
9.5 turning the area counter off	61
9.6 power supply	61
9.7 installing the sensor and magnet	62
10 G-Wizard	63
10.1 general	63
10.2 DRIVING MODE WITHOUT REMOTE FERTILISER CONTROL (G-WIZARD)	65
10.3 DRIVING MODE WITH REMOTE FERTILISER CONTROL (G-WIZARD PLUS)	66
10.4 Machine guard	68
10.5 Calculators	69
10.6 Settings	70
10.6.1 Calibration (G-Wizard Plus)	70
10.6.2 User settings	71
10.6.3 Factory settings	72
10.6.4 Diagnostics	72
10.6.5 Alarm	72

11 JUNKKARI ISOBUS ECU TECHNICAL SPECIFICATIONS	74
11.1 Functions – Junkkari	74
11.2 Alarms, warnings, indicator lights, and buttons	75
11.3 Functions on the screen	76
11.4 Front page buttons	77
11.4.1 Track marker menu	77
11.4.2 Tramline rhythm selection	78
11.4.3 Pause on/off	78
11.4.4 Settings	79
11.4.5 Hopper sensors on the main	84
11.4.6 Half lift on the main screen	84
11.4.7 Gearbox alarm on the main screen	84
11.4.8 Pole lift activation on the main screen	84
11.4.9 Fertiliser remote adjustment on the main screen	85
12 SEEDING	86
12.1 start of seeding	86
12.2 SOIL PREPARATION	86
12.3 fertilisation	87
12.4 seeds and seed feeding	87
12.5 economical seeding	88
13 OTHER OPTIONAL EQUIPMENT	90
13.1 Packer	90
13.2 SMALL SEED AND STARTER FERTILISER DEVICE	90
13.3 front leveller	91
13.4 S-tine	92
13.5 disc cultivator	92
14 MAINTENANCE AND SERVICING	93
14.1 EMPTYING, CLEANING AND STORING THE MACHINE	93
14.2 lubrication and greasing	94
14.3 gearbox	96
14.4 tyres	96
14.4.1 tyre pressures	96
14.4.2 changing tyres	96
14.5 REPLACING WEARING COULTER PARTS	97
14.5.1 REPLACING s-series WEARING COULTER PARTS	97
14.5.2 REPLACING m-series WEARING COULTER PARTS	99
14.5.3 Replacing wearing D-series coulters parts	100
14.6 REPLACING THE METERING DEVICE'S BOTTOM FLAP AND ROLL	101
14.6.1 Replacing a bottom flap	101
14.6.2 adjusting a bottom flap	102
14.6.3 Replacing the feed roller	102
15 TROUBLESHOOTING	103
16 ELECTRICAL DIAGRAMS	106
17 Assurance of compliance with ec regulations	107

1 DEAR CUSTOMER

We wish to thank you for the trust you have shown in Junkkari, and wish you the best of success. Please read this operating manual carefully because full knowledge of the machine, correct adjustments and thorough maintenance ensure the safety of users, productive results and continuous machine operations during busy working days. It is important that you understand every single section of this manual and follow all operating instructions.

Junkkari team

1.1 SPARE PARTS CATALOGS

You can find Junkkari spare parts catalogues at <https://www.junkkari.fi/en/web/en/manuals>



1.2 JUNKKARI WARRANTY

JUNKKARI WARRANTY

You can have two years' warranty for your new Junkkari machine by registering it!

Register it by using the link or QR-code below.

<https://nps.trustmary.com/o9bAyZXZ->



2 TECHNICAL SPECIFICATIONS

	S 300/S 400	M 300/M 400	D 300/D 400
Coulters			
Soil preparation	Minimum or conventional tillage	Direct seeding (1), minimum or conventional tillage	Direct seeding, minimum or conventional tillage
Coulter type	Single disc	Single disc	Double disc
Depth control	Wedge shaped coulter	Wedge shaped coulter	Depth control wheel
Coulter durability	Good	Excellent	Excellent
Coulter pressure range	5 - 30 kg	10 - 140 kg	60-220kg
Coulter pressure adjustment	Mechanical central adjustment	Hydraulic central adjustment	Mechanical for each coulter
Pressure element	Tension spring	Tension spring	Compression spring
Seed coulters, pcs	24/32	24/32	18/24
Row spacing, seed	12,5 cm	12,5 cm	16,7 cm
Fertilizer placement	Fertilizer coulter/seed coulter	Fertilizer coulter/seed coulter	Seed coulter
S-tine fertilizer coulter	Option	-	-
Fertilizer disc coulter	Option	Option	-
Fertilizer double disc coulter	Option	-	-
HOPPER			
Options	Eco, Plus or Seed		
Volumes	2700/3700L, 4200/5700L or 2700/3700L		
Partition wall	Adjustable (no wall in Seed version)		
Sieves for fertilizer	Standard (not in Seed)		
Sieves for seed	Option		
Tarpaulin cover	Manual rolling /spring operated (Plus)		
Metering device, fertilizer	Rifle feed, gearbox adjustment		
Metering device, seed	2 studded wheels, gearbox adjustment		
Small seed box	Option		
PACKER WHEELS			
Tyre options	7.5 - 16 / 7.5 - 20		
Brakes	Option for 7.5-20		
CONTROL UNIT			
Options	Classic / G-wizard / ISOBUS		
Tramlines for fertilizer	Option		
Tramlines for seed	Option		
Fertilizer remote control	Option		
Seed remote control	Option		
Precision farming solution	Option		
OPTIONS			
Track marker, hydraulic	Option	Option	Option
Front packer, small	Option	-	-
Front packer, big	Option	Option	Option
1-row leveler	Option	Option	Option
2-row leveler	-	Option	-
2-row s-tines	-	Option	-
Disc cultivator	-	Option	-
Calibration kit	Standard	Standard	Standard
DIMENSIONS			
Working width	300/400 cm		
Transport width	300/400 cm		
Transport height	225-230cm	268-273cm	268-273cm
Working height	185-190cm	223-228cm	223-228cm
Length	520-620cm	530-700cm	530-630cm
Weight	min. 2500kg/3100kg	min. 3200kg/3900kg	min. 3950kg/ 4700kg
Power demand	55-95 kW /75-115 kW	60-115 kW /75-140 kW	65+ kW / 85+ kW
Strength of sound	70 dB(A)		

1) not suitable for direct seeding in heavy soils
The factory reserves the right to changes without prior notice.

Table 1. Technical specifications

3 MACHINE PRESENTATION

Junkkari S, SH, M, T and D seed drills are modern mechanical drills that, depending on their equipment level, are intended for applying seeds or seeds and granulated fertilisers.

The operating power of Junkkari S, SH, M, T and D machines is produced by a friction wheel, and the seeding volume is adjusted through the gearbox by changing the rotating speed of the feeding roll. Seeds are fed using a double studded roll, while fertiliser is fed using a rifle-type feed roll. After using coulters, the surface of the field is closed using the wheels and cultivated for improved water economy. Two different drawbars can be selected for seed drills: Steady and Heavy. Only the Steady drawbar can be selected for the S- and SH-series, and only the Heavy drawbar can be selected for the D series. Both drawbars can be selected for the M- and T-series with the following conditions:

Heavy drawbar when a 2-row front tool or a separate fertiliser coulters unit is installed.

Steady drawbar when a 1-row front tool is installed.

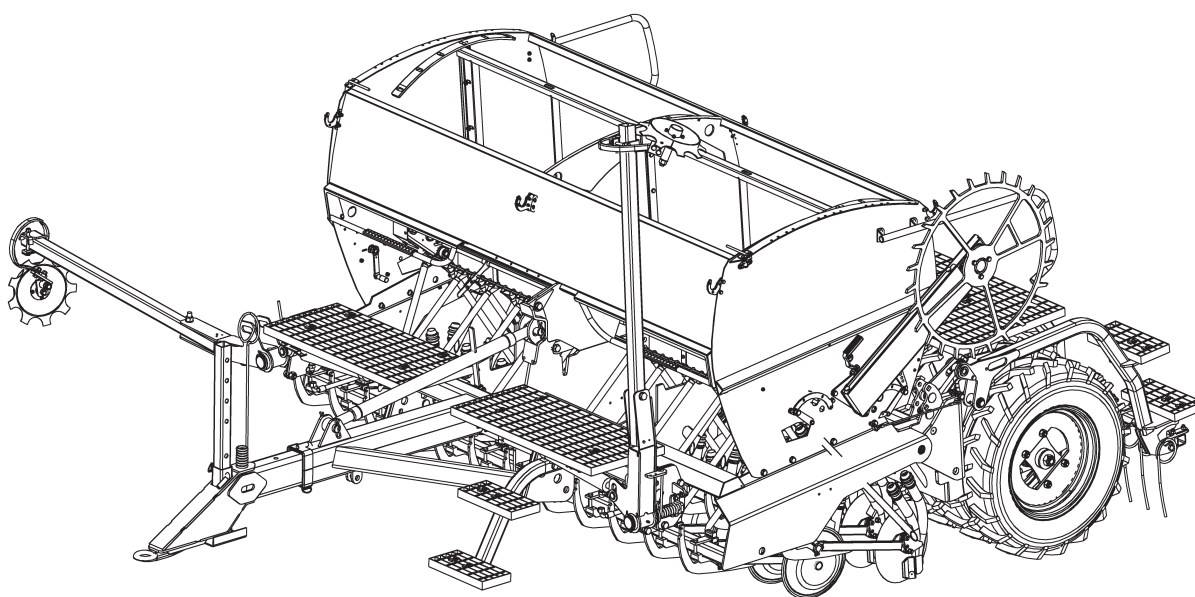

Picture 1. S-series (Optional trackmarker)

3.1 S- AND SH-SERIES

The S-series is designed for seeding in cultivated soil. At the acquisition stage, you can choose whether the coulters position any fertilisers on the seed row or on a separate fertiliser row. The machine's simple and reliable wedge-shaped coulters excellently maintain their working depth in varying soil.

The SH-series is similar to the S-series in terms of its geometry, while the maximum coulters weight is 60 kg in the SH-series and 30 kg in the S-series.

Dimensions of the S- and SH-series

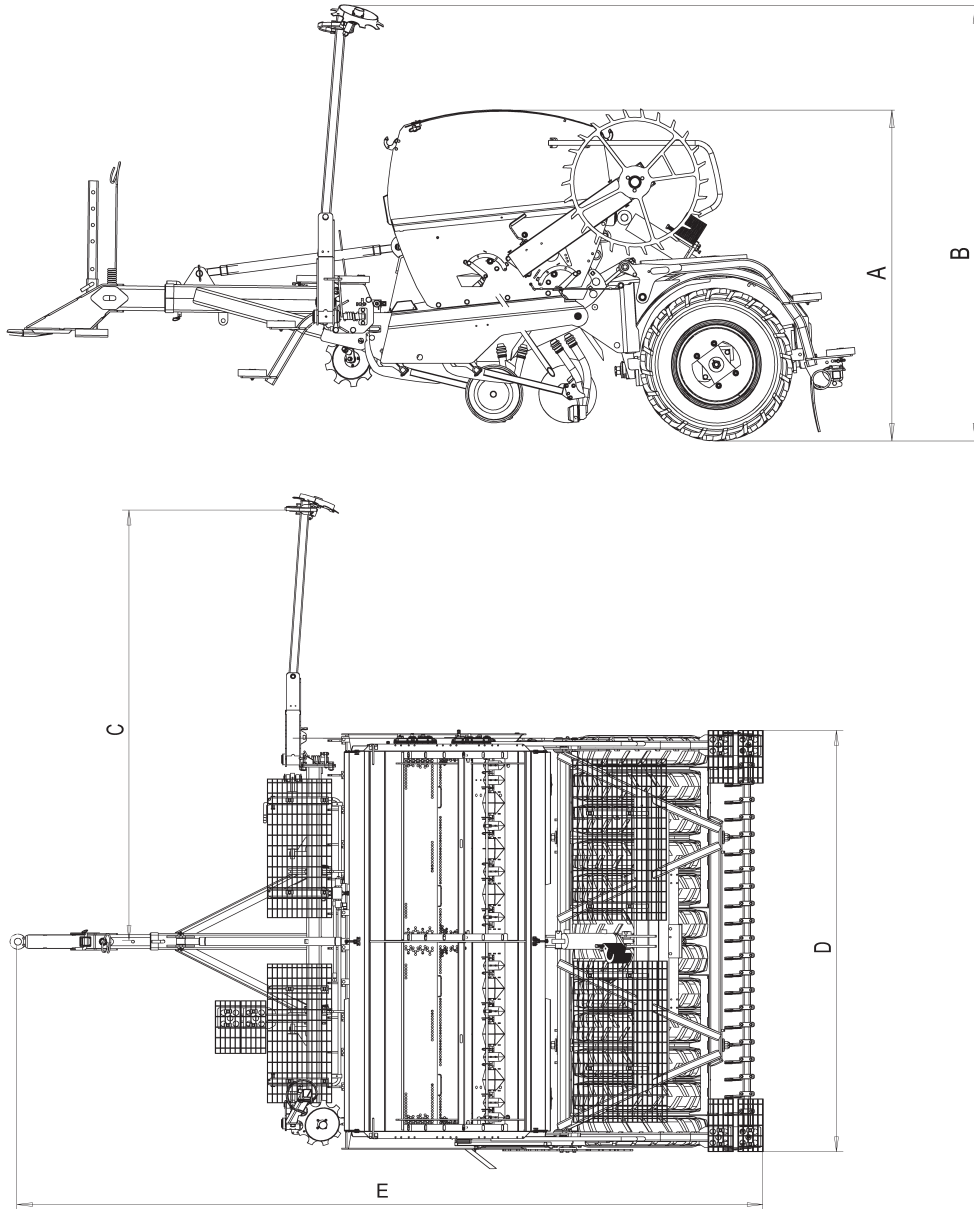

Picture 2. S-series dimensions (Optional trackmarker)

	S300ECO	S300PLUS	SH300PLUS	S400PLUS	SH400PLUS
A	1885	2160	2160	2160	2160
B	2485	2485	2485	2485	2485
Bmax	2860 (16")	2910 (20")	2910 (20")	3410 (20")	3410 (20")
C	3000	3000	3000	4000	4000
D	3000	3000	3000	4000	4000
E	5475	5475	5475	5475	5475
Emin	4740	4740	4740	4740	4740
Emax	6450	6450	6450	6450	6450

Table 2. S-series dimensions (mm)

3.2 M-SERIES

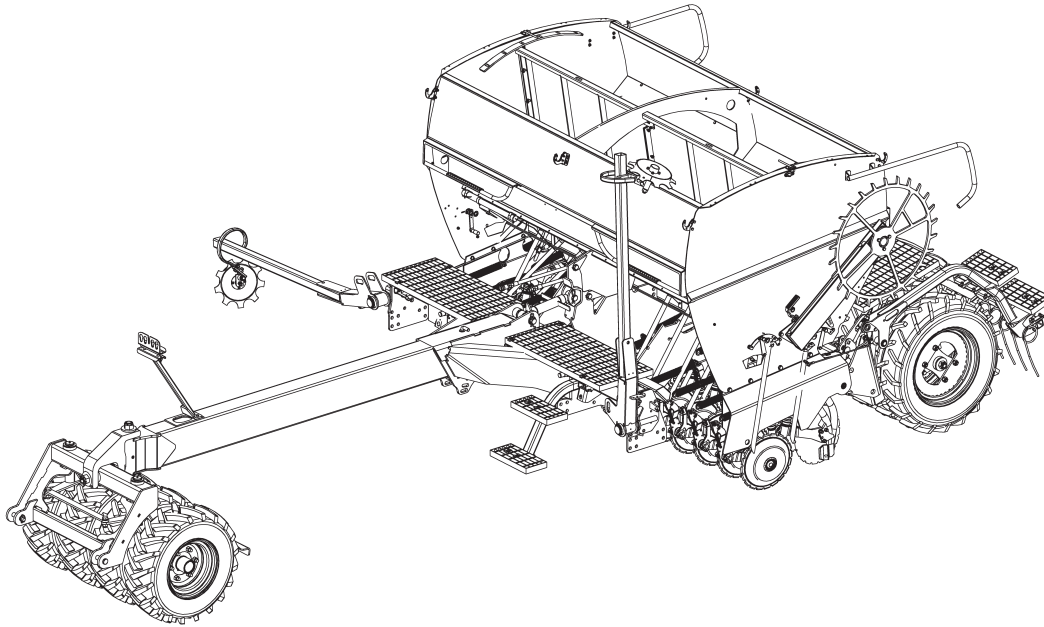

Picture 3. M-series (Optional trackmarker and packer)

The M-series is designed for diverse seeding from light direct seeding to cultivated soil seeding and cultivation performed during seeding. At the acquisition stage, the customer can choose whether to position any fertilisers on the seed row or on a separate fertiliser row. The machine's sturdy wedge-shaped coulters offer a simple working depth control. Accompanied with the extensive adjustment range of hydraulic coulters pressurisation, the machine is a highly versatile and effective seed drill. The large cultivator range adds to the machine's versatility.

M-series dimensions

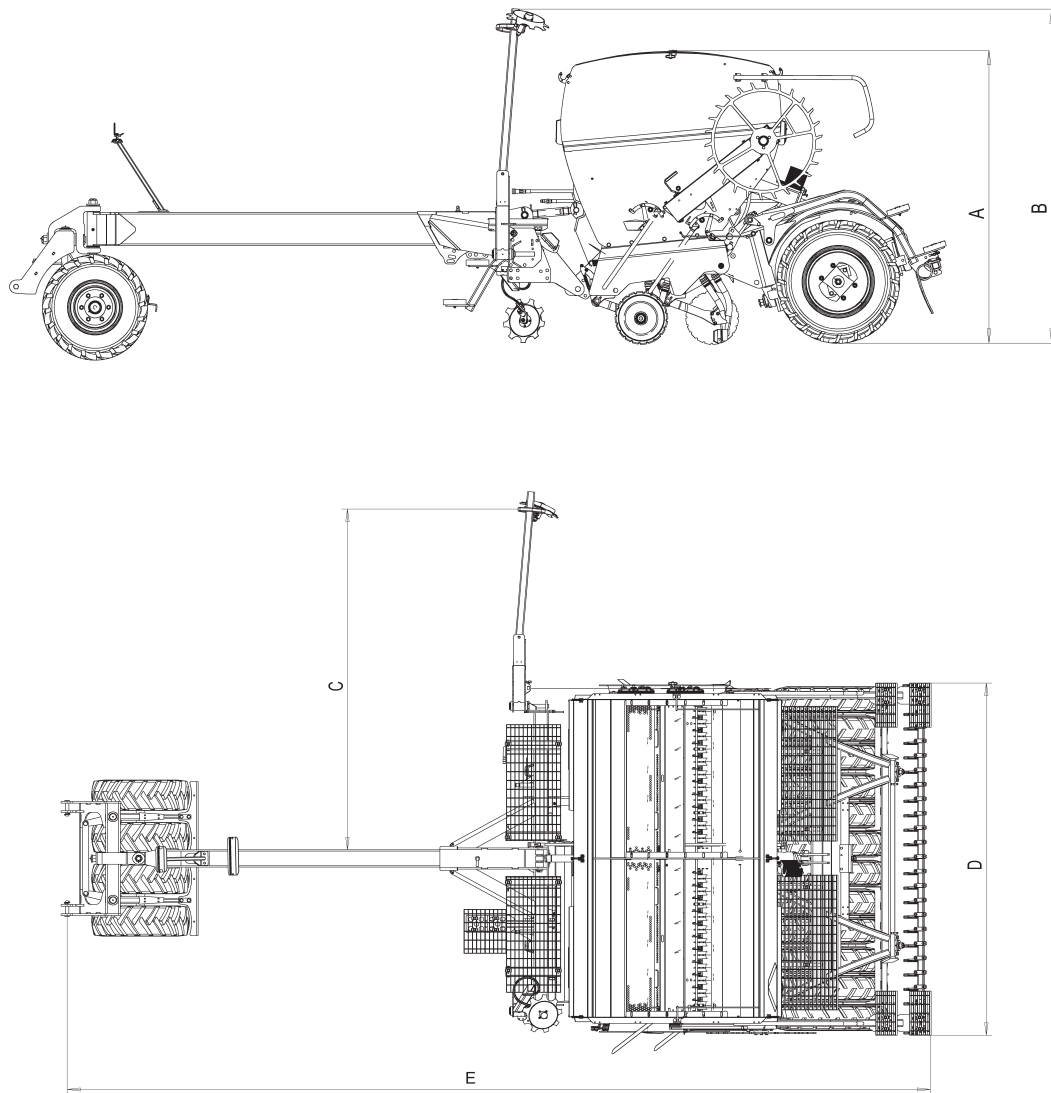

Picture 4. M-series dimensions (Optional trackmarker and packer)

	M300ECO	M400ECO	M300PLUS	M400PLUS
A	1935	1935	2210	2210
B	2530	2530	2530	2530
Bmax	2970 (16")	3470 (16")	3020 (20")	3520 (20")
C	3000	4000	3000	4000
D	3000	4000	3000	4000
E	7050	7050	7050	7050
Emin	5390	5390	5390	5390
Emax	7980	7980	7980	7980

Table 3. M-series dimensions (cm)

3.3 T-SERIES

The T-series is designed for diverse seeding from light direct seeding to cultivated soil seeding and cultivation performed during seeding. In the T-series, the coulters disc is specifically designed for hard soil. In addition, the maximum coulters weight is 30 kg higher than in the M-series.

At the acquisition stage, you can choose whether the coulters position any fertilisers on the seed row or on a separate fertiliser row. The machine's sturdy wedge-shaped coulters offer a simple working depth control. Accompanied with the extensive adjustment range of hydraulic coulters pressurisation, the machine is a highly versatile and effective seed drill. The large cultivator and optional equipment range adds to the machine's versatility.

3.4 D-SERIES

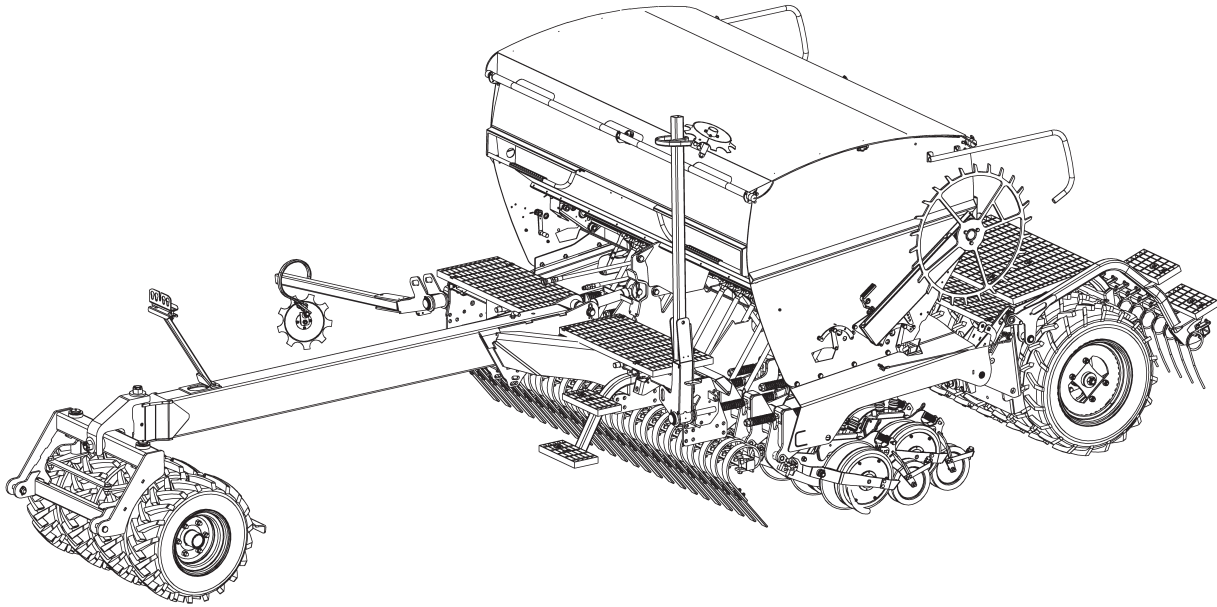

Picture 5. D-series (track marker and packer as optional equipment)

The D-series is principally designed for direct seeding but, thanks to its large coulters pressurisation range and large depth wheels, the machine can be used in various cultivated soils. The machine's highly robust double-disc coulters also serve to apply any fertilisers. The seeding depth is adjusted for each coulters using the depth control wheel. The seeding row is closed using the press wheel. Coulters pressurisation is adjusted electro-hydraulically, which is a major advantage in varied or hilly field parcels.

D-series dimensions

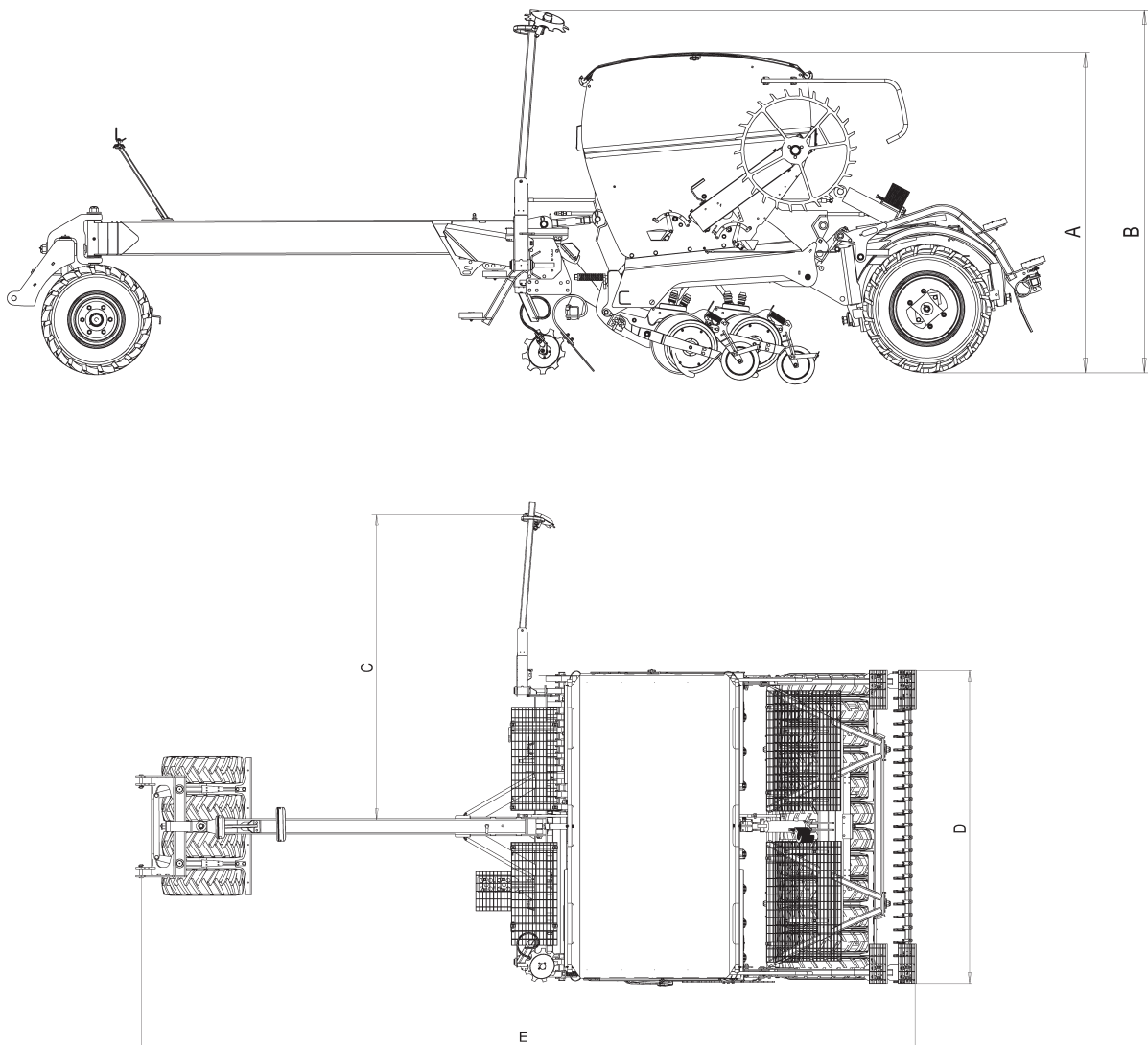

Picture 6. D-series dimensions (Optional trackmarker and packer)

	D300ECO	D400ECO	D300PLUS	D400PLUS
A	2050	2050	2325	2325
B	2645	2645	2645	2645
Bmax	2970 (16")	3470 (16")	3020 (20")	3520 (20")
C	3000	4000	3000	4000
D	3000	4000	3000	4000
E	7505	7505	7505	7505
Emin	5910	5910	5910	5910
Emax	8510	8510	8510	8510

Table 4. D-series dimensions (cm)

4 SAFETY

Before using the machine, carefully read the operating manual !

4.1 SYMBOLS OF THE MANUAL



This manual uses this symbol whenever a hazard to the user or other individuals is present. In addition, the symbol indicates a hazard to the environment or property.



This symbol indicates the importance of the proper use of the machine in a situation where the use of the machine may otherwise cause problems.



This symbol indicates additional information which may be useful for the operation of the machine.

4.2 GENERAL SAFETY INSTRUCTIONS

4.2.1 OPERATIONAL LIMITATIONS AND PROHIBITED USES

- The user of the seed drill must not be under the influence of narcotics, alcohol or strong medicinal products.
- In case of illnesses or disabilities, a physician may authorise the user to operate the machine.
- The seed drill must not be used by persons who do not possess proper agricultural know-how and persons who are under 15 years of age.
- The use of the machine should be avoided in particularly wet or dry conditions where the access of reasonable moisture to seeds cannot be guaranteed.
- The machine must not be operated in protective zones of water systems or any other nature conservation areas without separate permission from the authorities.
- The machine cannot be used to apply liquids, flammable materials, sand or powdery or fibrous substances.

4.2.2 BEFORE USING THE MACHINE

- Before using the machine, carefully read the operating manual and become familiar with all machine controls and operations.
- Observe all warnings and instructions presented on the machine.
- For your personal safety, wear proper work clothing and shoes.

4.2.3 MOVING THE MACHINE

- Always follow the traffic code when driving on public roads.
- Check that all the machine equipment required on public roads, such as lights, reflectors and the triangle warning of a slow moving vehicle are in place.
- Visibility backwards will be limited. Before reversing, make sure that no persons are behind the machine.
- Do not transport any passengers on the machine.

Moving the machine when connected to a tractor

- Observe special caution when connecting and disconnecting the machine.
- Never go between the machine and tractor when the machine is being connected, raised, lowered or moved.
- Pay attention to the maximum permitted load of the draw boom and tractor.
- Pay attention to maximum axle weights, total weights and transportation dimensions.
- Towed or lifted work machines and additional weights have an impact on how the tractor behaves, steers and brakes. As a result, make sure that the tractor's steering and deceleration capacity is at a sufficient level. Make sure that at least 20% of the tractor's weight lies on the front axle when the machine is filled and lifted.

Moved without being connected to a tractor

- If the machine is moved without being connected to a tractor, use equipment intended and suitable for transportation.
- The machine must be tied using proper chains or slings. Tying points on the frame are indicated by stickers. (Picture 7 and Picture 8)
- Always check the condition of the slings before lifting.
- When loading using a forklift or another hoist, make sure that the seed drill is balanced, and there is no danger of falling.
- Make sure that the cover is secured using straps or similar fasteners.
- Do not load any other products on the machine.

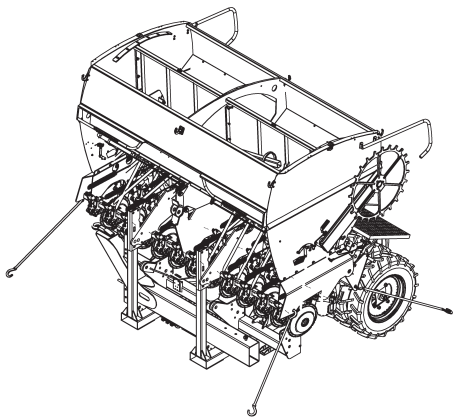

Picture 7. Tying the machine

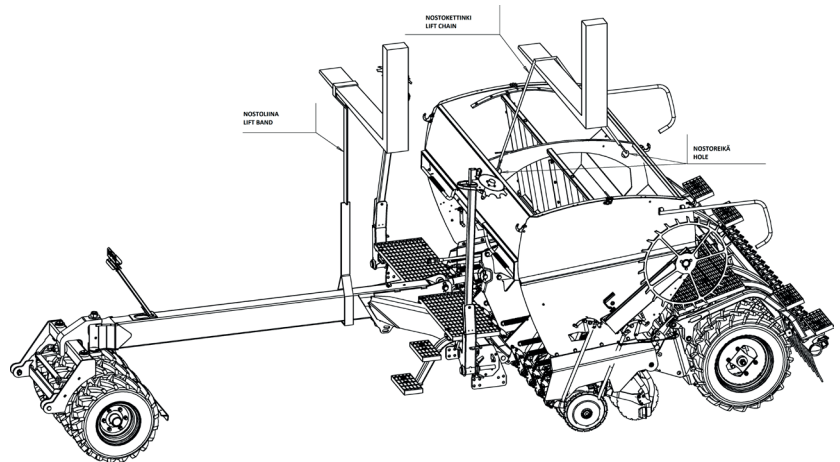

Picture 8. Lifting the machine

4.2.4 HANDLING THE MACHINE

- Make sure that the machine cannot move when parked.
- When working with the machine, do not stay on top of or close to the machine.
- After use, check the condition of the machine, focusing on fastening and connecting surfaces.

4.2.5 STORING THE MACHINE

- When stored outdoors, make sure that no water or snow can accumulate inside or on the machine.
- Any long-term storage must be performed indoors.
- Machine dimensions and weights are presented in section "Technical specifications" of this manual.

4.3 MACHINE-SPECIFIC SAFETY INSTRUCTIONS

4.3.1 MOVING THE MACHINE

- Lock the trackmarkers in the transportation position, lift the friction wheel up and make sure that the cover is closed. Also close the ball valve of lifting hydraulics.
- The maximum speed of the seed drill is 40 km/h. On uneven ground, reduce speed significantly. Excessive load is placed on the wheels if not all of them touch the ground.
- Do not transport any items, such as tools, seeds or fertilisers, on covers or steps.



4.3.2 DANGEROUS SITUATIONS

- When installing the support and friction wheel, there is a risk of getting crushed.
- When lowering the friction wheel to the seeding position, support the wheel with your right hand, while turning the wheel to its outward position using the machine lever with your left hand. Make sure that your feet do not remain under the lowering friction wheel!
- Before using the machine, make sure that the machine is correctly connected, and all its guards and safety devices are in place and in good condition. The machine must not be used without its guards in place.
- For the sake of the machine's operating principle, there are parts that cannot be fully protected. Always maintain a sufficient distance to these parts. When operating the machine, the driver must ensure that no persons are close to these parts. Be especially cautious of the moving trackmarker and harrow!
- Do not go under a machine raised using hydraulics without any supports or to places where a crushing hazard exists. When maintaining the machine, use the maintenance support fitted in the lifting cylinder and hydraulics shut-off valves.
- Do not go under a machine raised by draw arms. Support the machine mechanically during maintenance.
- Make sure that all mechanical supports remain upright and cannot sink into the ground.
- Always before adjustment and maintenance procedures, make sure that the tractor hydraulics and power are disconnected, the engine has been stopped and the ignition key removed.
- When adjusting the machine's half lift height (lifting sensor), the control must be disconnected before any adjustments.
- Do not overload the seed drill. Identify how large bags can be partially emptied.
- Do not damage machine parts with swinging large bags.

4.3.3 HYDRAULICS

- Take care when handling hydraulic parts. There is a risk of suffering crushing and cuts.
- Avoid skin contact with oil and grease because the skin may be damaged.

Pressure

- The maximum pressure of the hydraulics system is 210 bar.
- When connected, the hydraulic system is highly pressurised. Any hydraulic oil discharged at high pressure may penetrate through the skin and cause serious injury.
- No hydraulic connectors can be disconnected when the machine is supported by hydraulics only, because the system will remain pressurised. If required, use a maintenance support.
- When connecting a hydraulic hose to the tractor, the hydraulic system must not be pressurised on the machine or tractor side (the ball valve must be closed).
- When maintaining or repairing the hydraulic system, the seed drill must be on level ground and supported so that the machine cannot descend or otherwise move when hydraulic pressure drops.
- Always bleed the hydraulic system after any repairs. Make sure that no persons are inside the danger area and drive the lifting cylinder, trackmarker cylinder, any coulter pressurisation cylinder and front equipment cylinder a few times to their inner and outer extreme position, until all air has been removed from the system.
- When transporting the machine, close the ball valve of the lifting cylinder's hydraulic hose if it is possible that the tractor's hydraulic valve leaks. You can also use the lifting cylinder's maintenance support.

Oils and greases

- Follow the handling instructions of lubricant manufacturers and safety regulations.
- Always wear proper protective clothing and oil-resistant gloves when handling oil or grease.
- Avoid skin contact with oil and grease because the skin may be damaged.
- Never use oil or lubricants to clean your skin! They may contain small metal particles that cause cuts made worse by oil.
- Synthetic oils are often corroding and cause serious skin irritation.
- Any waste oil must be collected and disposed of properly according to national regulations.
- If any oil accesses the soil, its spreading must be prevented and the oil must be recovered by absorbing it into peat.
- If oil or grease causes skin damage, immediately contact a physician.

4.3.4 NOISE

The emitting sound pressure level of the machine does not exceed the 70 dB level at the working positions (tractor cab).

4.4 WARNINGS STICKERS, SAFETY COMPONENTS AND TYPE PLATE

4.4.1 WARNING STICKERS

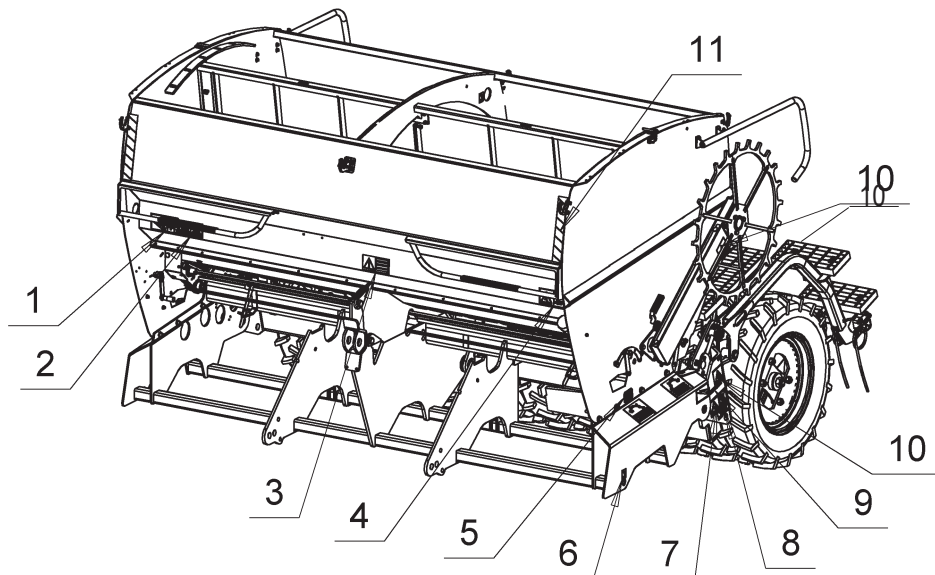

Picture 9. Locations of stickers on the machine

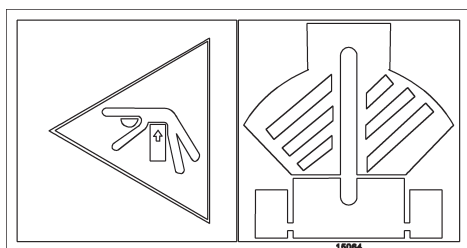

1. DANGER OF SQUEEZING

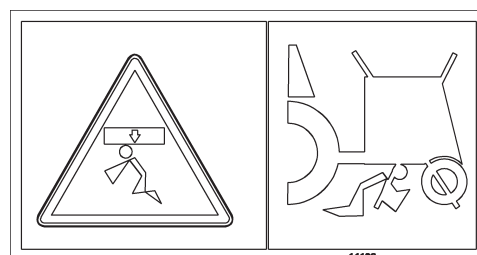

4. IT IS FORBIDDEN TO GO UNDER THE MACHINE

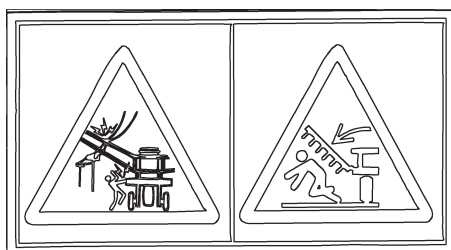

2. BEWARE OF FALLING BOOMS

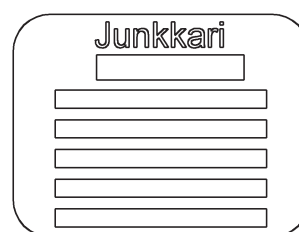

5. TYPE PLATE

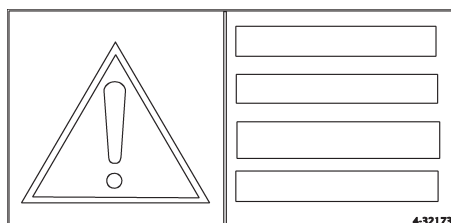

3. BECOME FAMILIAR WITH THE OWNERS MANUAL AND SAFETY INSTRUCTIONS BEFORE STARTING TO OPERATE THIS MACHINE.

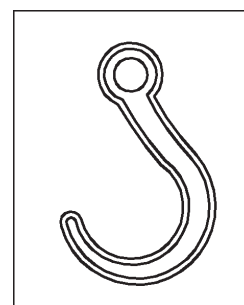

6. LIFTING EYE

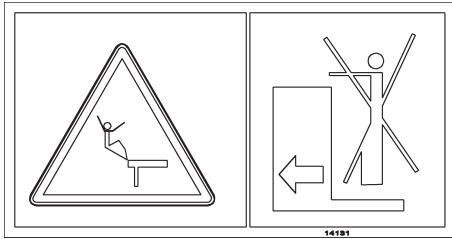

7. TRANSPORTING PASSENGERS IS FORBIDDEN

Tyre	kPa	
11.5*15.3"	200	
400*15"	210	
7.0*12"	180	
7.5*16"	180	
7.5*20"	180	
10*15.3"	200	16257

8. TYRE PRESSURE

HUOM! Kiristä pultit 3h ajon jälkeen.
 OBS: Spänn bultarna efter 3 timmar körning.
 NOTE: Tighten bolts after 3 hours of operation.
 ACHTUNG: Bolzen nach 3 Stunden Fahrt festziehen.

9. TIGHTEN BOLTS

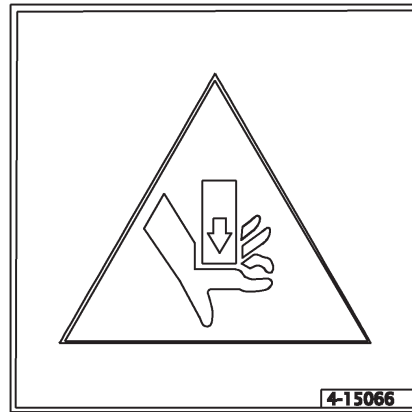

10. LRISK OF CRUSHING OR CUTS



11. OVERSIZE MACHINE

4.4.2 SAFETY COMPONENTS OF THE MACHINE

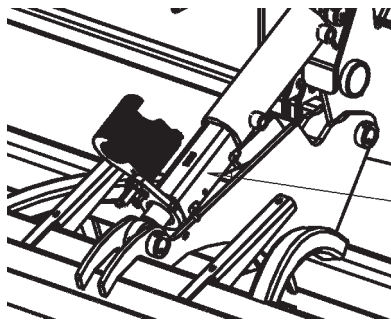

Service support

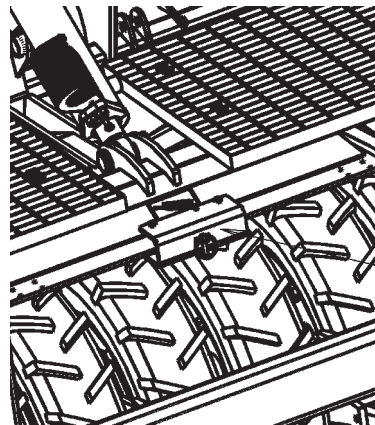

Serive support position

4.4.3 TYPE PLATE

1. Name and address of manufacturer
2. Name
3. Type
4. Serial number
5. Weight
6. Manufacturing year
7. CE-mark

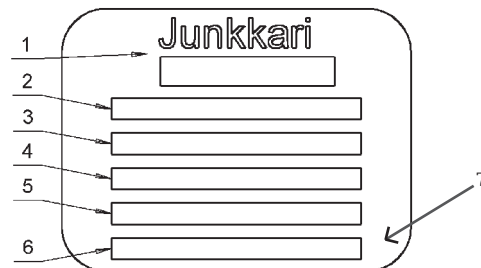

Type plate

4.5 WARRANTY TERMS

Please read carefully the warranty terms and limitations of the warranty. Remember that agricultural machines should be handled with care and maintained regularly so that they can work as smoothly as possible for as long as possible.

WARRANTY TIME

- The warranty period 24 months provided that the machine is used for its intended agricultural purposes.
- The warranty period starts from the date of delivery by an authorized dealer.
- In all cases, the warranty period ends at the latest 36 months after the delivery of the machine at Junkkari's factory.

THE WARRANTY WILL COVER

- The warranty will cover manufacturing and material defects. Damaged parts will be repaired or exchanged for parts in full working order at the factory or at an authorised repair workshop. Subcontracted components are covered by the warranty policies of their manufacturers.
- Repair work and the potential costs must be agreed on with the manufacturer before any repair work is carried out.
- Repairs carried out within the warranty period will not extend the warranty period.

THE WARRANTY WILL NOT COVER

- The warranty will not cover damage caused by incorrect use contrary to the practices laid out in this manual, incorrect maintenance, excessive loading or normal wear. Furthermore, the warranty will not cover subsequent damage, down-time, travel expenses, freight charges, daily allowances, overtime expenses or cases in which the original machine design has been modified.
- The warranty will not cover subsequent damage, down-time, travel expenses, freight charges, daily allowances, overtime expenses or cases in which the original machine design has been modified.
- The warranty does not cover any damage caused by carriage, vandalism, theft, etc.

ANNOUNCING A FAILURE

- For warranty claims written request to Junkkari must be sent promptly.
- The request shall be accompanied by appropriate pictures and explanations of the occurrence of the fault and its effect on the usability of the machine
- When requested separately, the faulty part (s) must be returned as original and unrepaired to Junkkari.



4.6 RESPONSIBILITIES

- The manufacturer cannot be held liable if the seed drill is used contrary to laws, safety regulations or this manual. Because situations not governed by guidelines or regulations may arise when using the seed drill, users are advised to follow general machine safety guidelines and directives.
- Please note that any incorrect use of fertilisers and pesticides may cause damage to people, animals, water systems and the soil. Follow the instructions of their manufacturers and other specialists on their handling and use.
- Furthermore, the manufacturer is not responsible for the selection of the seed, pesticide or fertiliser volume. If the user has insufficient information, he/she should contact specialists.
- The manufacturer cannot be held liable for unsuccessful seeding. The user must always monitor the consumption of seeds and fertilisers and, thus, make sure that the seeding volume is at a reasonable level in all feeding compartments. The user must also ensure that the seeding depth is correct.
- The manufacturer is not responsible for any damage caused by the use of components of other manufacturers.
- In addition, the manufacturer is not responsible for any damage to other machinery or equipment caused by the use of the seed drill.
- The manufacturer reserves the right to further develop or alter the machine structure.
- The machine owner is responsible for ensuring that all persons who operate the machine have read the machine's operating and safety instructions.

4.7 DECOMMISSIONING

- The end user or the person or company that owns the machine when it is decommissioned is fully responsible for its decommissioning.
- The decommissioning of the machine and the handling of waste produced are governed by national laws, guidelines and regulations that must be followed.
- As most seed drill parts are made of non-biodegradable materials, the machine must be disassembled and different materials must be disposed of according to national regulations.
- Iron and other metals must be recycled through machinery and equipment shops in order to be reused.
- Waste oil, plastic and rubber parts, such as tyres, must be handled as hazardous waste and disposed of by recycling or transporting them properly to a landfill site, or otherwise disposed of according to national regulations.
- Tyres must be disposed of according to directives 83/189/EEC, 182/88/EEC and 94/10/EC by returning used tyres to recycling outlets or operators that forward them to further processing.
- For further information about disassembly and waste handling, contact environmental authorities.

5 COMMISSIONING

Once the machine has been delivered, check the condition of the machine and the content of the delivery. Also make sure that there is no transportation damage. If the delivery is defective and a customer complaint is needed, contact the retailer within eight days.

Depending on the machine and its equipment level, the machine is delivered in one or more parcels.

The machine is wrapped in plastic and includes the following parts:

- Operating manual in a protective tube in the front machine corner
- Lights and reflectors installed in place
- Calibration lever in its designated holder in the right front corner
- Calibration tray in place on the frame or in the hopper
- Fertiliser sieves in place in the hopper
- Pushing arm in the hopper
- Following harrow arms in the hopper, tine boom on wheels
- Control unit in the machine hopper or attached to the front of the hopper (surface area meter)
- Toolkit in the hopper
- Trackmarker arms in the hopper
- Cover on the hopper or wheels
- Drawbar and arm under the machine or in a separate parcel
- Small seed or starter fertiliser device attached to the machine
- Large additional equipment is usually transported in separate parcels.

Wooden and plastic packaging materials can be disposed of by burning. Plastics and any reusable pallets should be recycled. If local regulations deviate from these instructions, follow the guidelines of local authorities.

5.1 OPENING THE TRANSPORTATION PACKAGE

5.1.1 OPENING THE S- AND M-SERIES TRANSPORTATION PACKAGE

Junkkari S- and M-series machines are delivered with the drawbar, harrow and trackmarkers detached. The drawbar must be connected to the machine when opening the package.

 **When opening the machine transportation package, be especially careful not to cause any damage to people or property.**

1. Place the transportation package on level ground and make sure that there is room behind the package so that the seed drill can be moved backwards.
2. Remove any protective plastic.
3. Attach a lifting device with a lifting capacity of more than 2,500 kg to the fastening point on the seed drill's pushing arm and slightly lift the seed drill upwards using slings. (Picture 10)
4. Remove diagonal supports from between transportation forks and the wheel set frame. (Picture 11)
5. Lighten the front of the machine so that you can remove the fastening pins of the machine frame from the transportation base.
6. Move the machine backwards so that you can lower it behind the transportation package on maintenance or other such supports. Place maintenance supports under both front corners of the machine. Make sure that the machine is properly supported before lowering it.
7. Remove the transportation base from in front of the machine and attach the drawbar and pushing arm to the front of the machine. (Picture 12)
8. Attach the draw boom and hoses connected to the tractor. In the M-series, hoses and cables are drawn inside the draw boom. In the S-series, hoses and cables are drawn outside the draw boom.
9. Lift the machine so that it is supported by the draw boom.

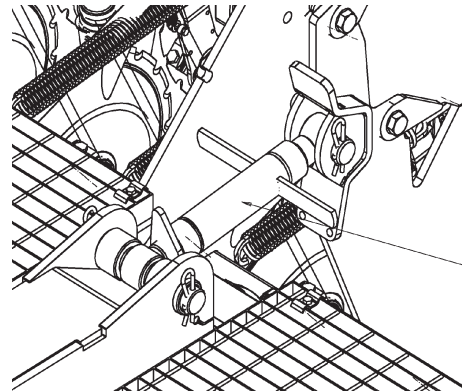

Picture 10. Fastening point of the pushing arm

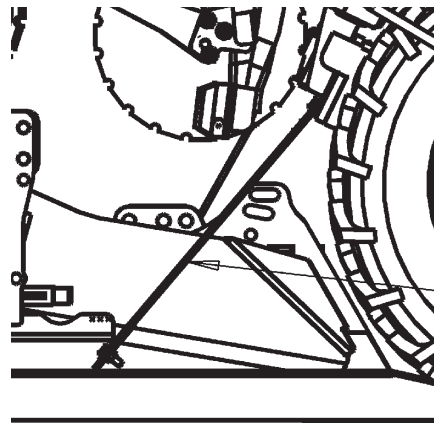

Picture 11. Diagonal supports

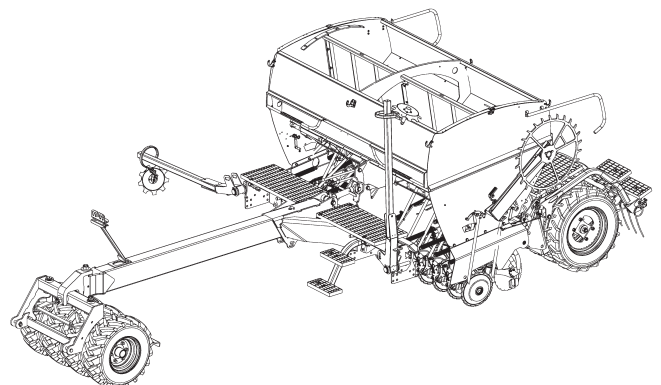

Picture 12. Machine with the drawbar and boom assembled

5.1.2 OPENING THE D-SERIES TRANSPORTATION PACKAGE

Depending on the transportation method, Junkkari D-series machines are delivered with the wheels detached, meaning that the wheels and drawbar must be attached to the machine when opening the package.

Three stages of dismantling the D-series package:

1. Unpacking the packages
 2. Installing the hopper and wheel set
 3. Installing the draw bar and draw boom
- ⓘ Use a lifting device with a lifting capacity of more than 2500 kg.

Unpacking the packages:

1. Place the transportation package on level ground and make sure that there is room behind the package so that the seed drill can be moved backwards.
2. Remove any protective plastic.

Installing the hopper and wheel set:

1. Attach a lifting device to the hopper and lighten it slightly by lifting with slings.
2. Remove diagonal supports.
3. Raise the hopper on a flat and hard surface for maintenance supports, etc. and make sure the hopper is properly seated.
4. Attach a lifting device to the wheel set and lighten it slightly by lifting with slings.
5. Remove diagonal supports.
6. Raise the wheel set and attach it to the hopper.

Installing the draw bar and draw boom:

1. Remove draw bar.
2. Raise the draw bar with slings and attach it to the hopper.
3. Remove draw boom.
4. Raise the draw boom with slings and attach it to the draw bar.
5. Attach hoses and cables inside the draw boom.

5.2 INSTALLING THE HARROW

1. Attach harrow arms to the pin in the wheel set. (Picture 13)
 2. Install the harrow lifting mechanism to the lugs in the rear corners of the frame. (Picture 14)
- ⓘ When installing, pay attention to the correct handedness of harrow arms.
3. Once the arms have been installed, install the tine boom to the arms as shown in the picture. (Picture 16)

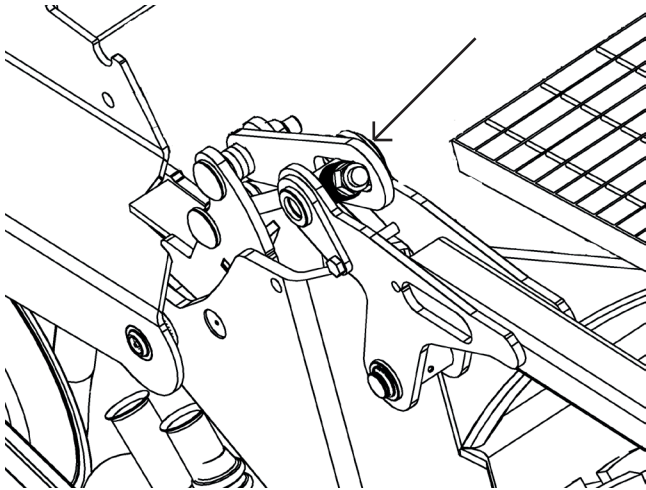

Picture 13. The pin in the wheel set

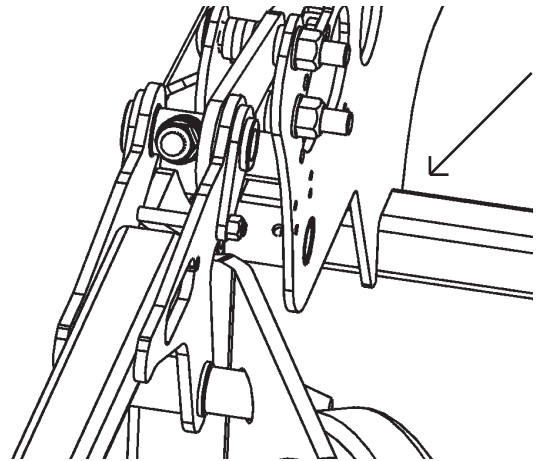

Picture 14. The lugs in the rear corners of the frame

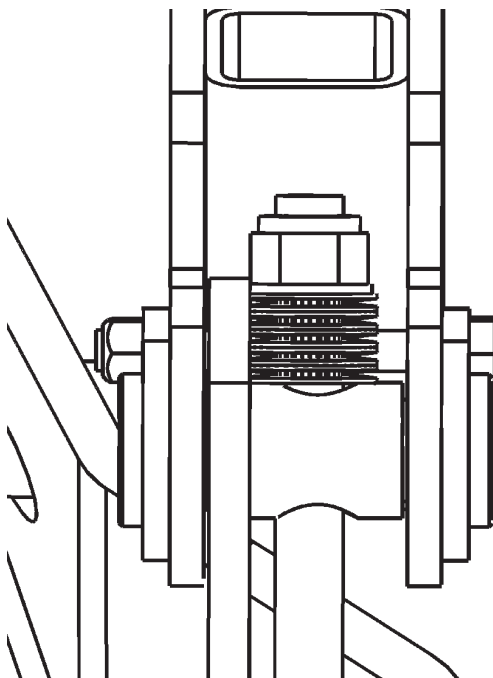

Picture 15. In the forward direction of the track, the left hinge pin

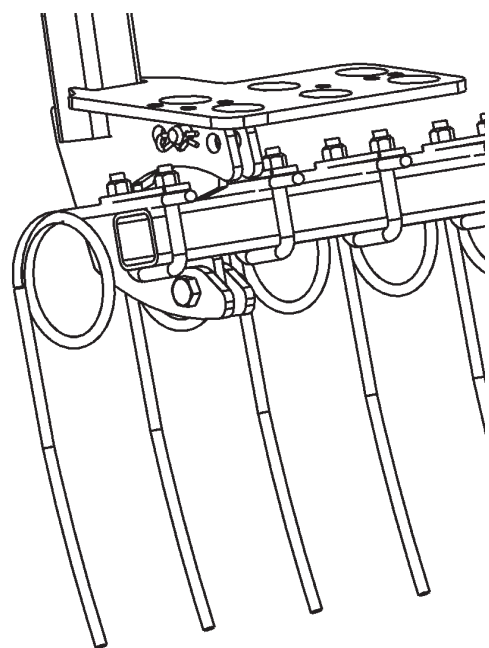

Picture 16. Mounting the harrowshaft

5.3 INSTALLING THE TRACKMARKER

1. Attach the hydraulic cylinders of the trackmarker to the trackmarker arms as shown in the picture. (Picture 17)

⚠ Pay attention to the correct position of the spring.

2. If required, adjust the cylinder arm length so that the cylinder stroke length is correct.

3. Attach the top of the trackmarker to the lower arm as shown in the picture. (Picture 18)

⚠ Pay attention to the correct ploughing direction of the disc.

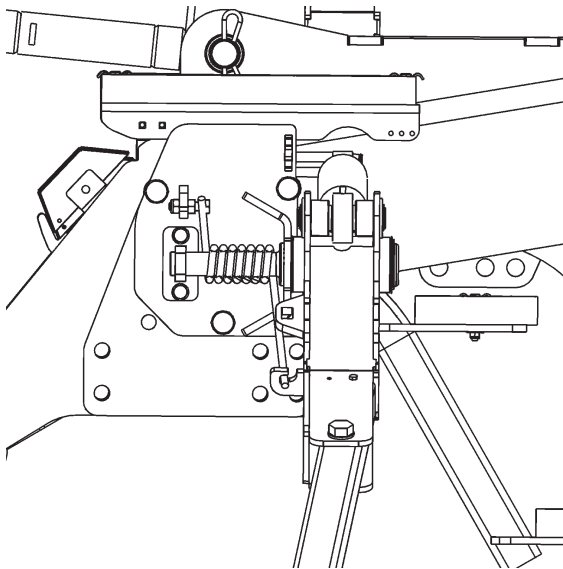

Picture 17. Trackmarker hinge, cylinder and arm assembled in the draw frame

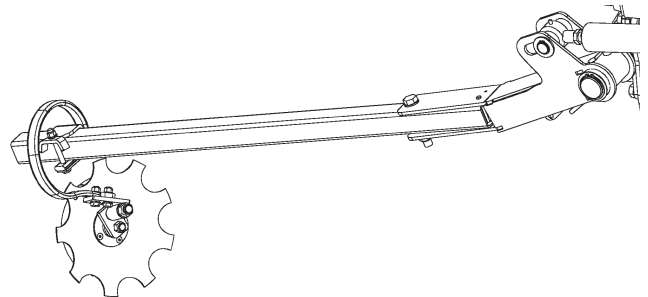

Picture 18. Fastening the assembled top part of the trackmarker

5.4 INSTALLING THE COVER

1. Install the cover so that front reinforcement pipe of the cover is aligned with the leading edge of the hopper.

2. The cover is attached using two fastening parts pushed to the ends of the reinforcement pipes in the cover.

3. You can tighten the cover using the fastening parts in the front and rear of the cover.

⚠ The fastening position determines the cover rolling point. The adjustment of fastening parts in the front and rear of the cover ensures that the cover tightens slightly when locked so that it remains secured.

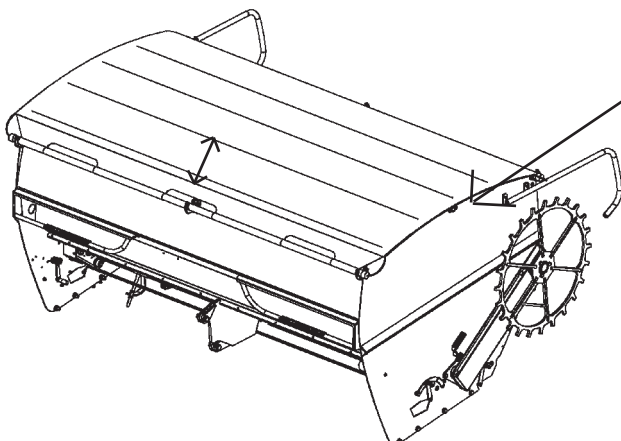

Picture 19. The cover



Picture 20. The fastening part



When fastening the cover opening cord to the hopper wall, make sure that the cord cannot get twisted around the mixer axle. Fasten the opening cord so that it stops the cover from rolling open.

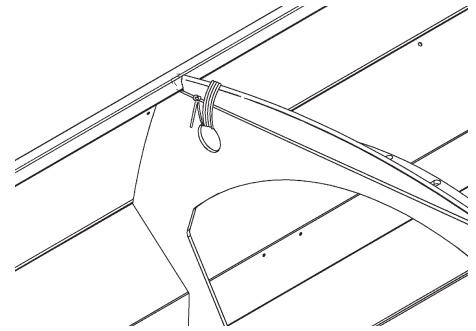

Picture 24. The opening cord fastening

5.5 INSTALLING THE CONTROL UNIT

Junkkari seed drills can be equipped with a surface area meter, G-Wizard control unit or ISOBUS compatibility. The ISOBUS seed drill is not normally delivered with a terminal because the seed drill can be controlled directly from the terminal of an ISOBUS-compatible tractor.

1. The surface area meter can be installed in front of the hopper or inside the tractor.
2. Use the delivered fastening parts..



Install it in a place where it does not block visibility but can be seen easily while driving. Adjust the distance so that you do not need to reach to touch any buttons..



If you need to drill holes into the tractor, make sure that you do not weaken any supporting structures or damage electric cables located inside structures.

3. Connect the control unit's data transfer cable to the screen. Use a through hole designed for the purpose.



Make sure that the cable is not pressed under the tractor's rear window. Connect the cable properly so that it is not pressed between draw arms or any packer joints when turning or lifting.

4. Connect the control unit's power cord to the tractor socket.

If there is no socket, one should be installed in the tractor. Connect current to the device directly from the battery. Preferably, use a 6 mm² cable. Make sure that the polarity and all connections are correct.



An incorrect connection may cause the device to work improperly. *Most faults in electrical devices of agricultural machines are caused by poor power supplies.*





Never use the cigarette lighter plug as a power source!

5.6 REQUIREMENTS SET FOR THE TRACTOR

The requirements set for the tractor's hydraulic system vary depending on the seed drill equipment:

Equipment	Hydraulic connection
Control the seed drill's lifting/lowering function and trackmarkers	Double-acting, 30-50 l/min, 180 bar
Control the hydraulic coulters pressurisation	double-acting in the S-, SH-, M- and T-series, 10-30 l/min, 180 bar; D-series, 5-15 l/min, 180 bar
Control the single row leveller	Double-acting, 10-20 l/min, 180 bar
Control two-row cultivators	Double-acting, 10-30 l/min, 180 bar

Table 5. The requirements set for the tractor's hydraulic system

-  The need for tractive force depends on the seed drill type, soil, and cultivator equipment. Indicative tractive force values are presented in the Technical specifications on page 6.
-  To reduce the compaction of soil and to balance tractive capacity, the tractor must be fitted with good tyres. If possible, use low tyre pressures. To secure a level substrate, the width of the tractor and seed drill should be identical. We recommend that a packer be used when rolling the gap between the wheels.



5.7 CONNECTING AND DISCONNECTING THE MACHINE

Always make sure that the seed drill is on level and firm ground. Make sure that any support stand is on sufficiently firm ground and the seed drill cannot move. Use the maintenance support when disconnecting the seed drill from the tractor. Never leave the machine hydraulics pressurised.

5.7.1 CONNECTING – WITHOUT A PACKER

1. Connect the seed drill to the tractor's drawbar.
2. Lift and lock the support stand to the upper position.
3. Connect hydraulic hoses and electric cables.
4. Make sure that the hoses and cables are not squeezed in tight turns.
5. Make sure that the tractor tyres or draw arms cannot collide with the seed drill's draw boom, platform, steps, cultivator, etc.
6. Regularly check the tractor drawbar and seed drill draw loop against wear.

5.7.2 DISCONNECTING – WITHOUT A PACKER

1. Install the maintenance support into place.
2. Remove hydraulic pressures from all hoses.
3. Make sure that the machine remains stationary and is on firm ground.
4. Lower the support stand.
5. Disconnect hydraulic hoses and electric cables.
6. Disconnect the seed drill from the tractor's drawbar.

5.7.3 CONNECTING – WITH A PACKER

1. Connect the packer connect to the tractor's draw arms.
2. Connect hydraulic hoses and electric cables.
3. Make sure that the hoses and cables are not squeezed in tight turns.
4. Lock the side limiters of the tractor's draw arms.
5. Make sure that the tractor tyres cannot collide with the seed drill's platform, steps, cultivator, etc.

5.7.4 DISCONNECTING – WITH A PACKER

1. Install the maintenance support into place.
2. Remove hydraulic pressures from all hoses.
3. Make sure that the machine remains stationary and is on firm ground.
4. Disconnect hydraulic hoses and electric cables.
5. Disconnect the seed drill from the tractor's draw arms.

5.8 CONNECTING HYDRAULIC HOSES AND ELECTRIC CABLES



Always make sure that hydraulic hoses or electric cables are not squeezed or otherwise damaged when lifting or turning.

5.8.1 CONNECTING HYDRAULIC HOSES

1. Always connect hydraulic hoses to the same hydraulic connectors. When using the same control levers, the risk of using incorrect functions is lower.
2. Check regularly that the hoses are undamaged.
3. Before disconnecting the hoses, remove any hydraulic pressure.

5.8.2 CONNECTING ELECTRIC CABLES

1. Before connecting the control unit signal cable, remove the cable protector.
2. Connect the cable cautiously and make sure that the

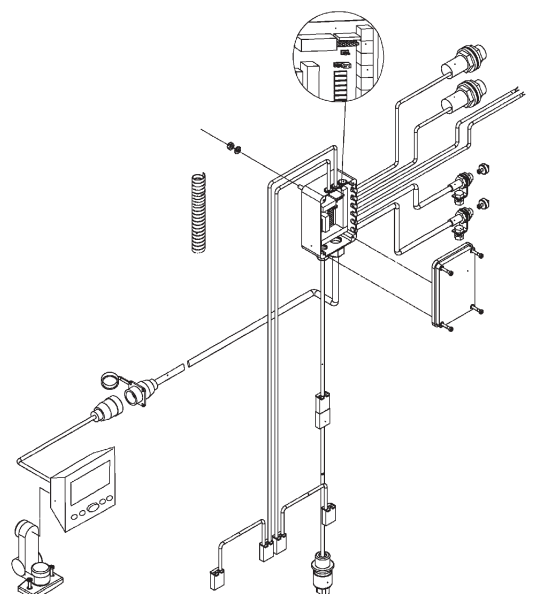

Picture 21. Connection of the signal cable

socket pins are correctly aligned.

3. Lock the cable using the socket's locking nut.

4. When disconnecting the cables, reattach the socket cover.

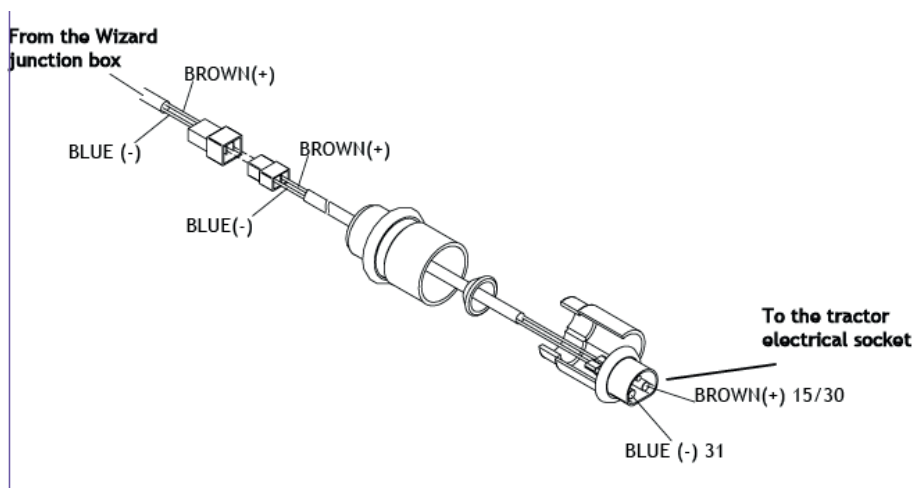

Picture 22. Connection of the power supply cable

Connect the control unit's power supply cable to the tractor socket.

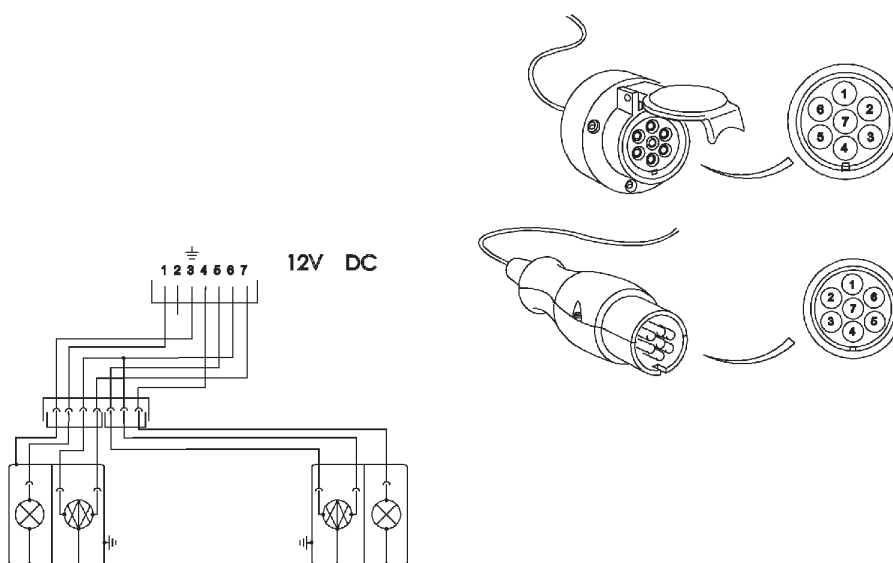

Picture 23. Connection of the light cable

Connect the seed drill's light cable to the tractor's 7-pin light socket

6 MACHINE ADJUSTMENT

The seed drill should be adjusted on level ground before any seeding. For producing a good seeding result, it is important that the machine and its equipment are adjusted correctly. Basic machine adjustments should be performed in the following order:

- 1) Adjusting the hopper wall
- 2) Aligning the packer (optional equipment)
- 3) Adjusting the height of the machine frame
- 4) Adjusting the machine horizontally
- 5) Adjusting the lifting height of the friction wheel
- 6) Adjusting the seeding depth
- 7) Adjusting the trackmarker alignment, ploughing and movement speed
- 8) Adjusting the height and aggression of the harrow
- 9) Adjusting the half lift height

6.1 HOPPER WALL (ECO AND PLUS)

The hopper wall can be adjusted in six different positions. The volumes of fertiliser and seed sides corresponding with different positions are presented in Table 6.

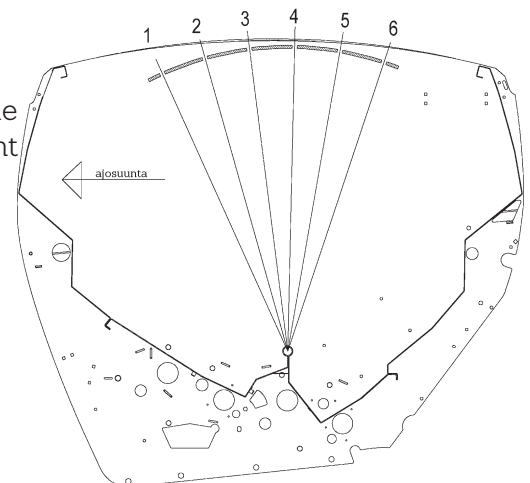

Picture 25. Hopper wall

	1	2	3	4	5	6
300 Eco						
seed	1485 l	1365 l	1240 l	1105 l	970 l	835 l
fertilizer	960 l	1170 l	1340 l	1495 l	1635 l	1770 l
300 Plus						
seed	2565 l	2370 l	2165 l	1955 l	1735 l	1515 l
fertilizer	1480 l	1735 l	1960 l	2175 l	2390 l	2585 l
400 Eco						
seed	1975 l	1805 l	1635 l	1450 l	1265 l	1080 l
fertilizer	1360 l	1650 l	1880 l	2090 l	2285 l	2470 l
400 Plus						
seed	3500 l	3230 l	2950 l	2665 l	2370 l	2065 l
fertilizer	2015 l	2370 l	2675 l	2970 l	3360 l	3530 l

Table 6. The volumes of fertiliser and seed

The wall is locked in place using three locking pins. Release the pin lock by lifting the pin upwards and turning it 90 degrees, after which the pin is released in its lower position. Lock in reverse order. If the cover is rolled open in the middle of the hopper, the cover rolling point can be adjusted according to the wall adjustment.

- ⓘ If the cover is rolled open in the middle of the hopper, the cover rolling point can be adjusted according to the wall adjustment. See cover adjustments in section 6.14.

6.2 PACKER

If the seed drill is equipped with a packer, the side limiters of the tractor's draw arms must be locked in the middle position so that the seed drill follows the tractor on its centre line. In particular, when driving on a slope, the seed drill will be driven towards the lower slope if the limiters have not been locked.

- ⚠ **When reversing, always remember to lift the packer up, otherwise, it will be damaged.**

6.3 HEIGHT OF THE MACHINE FRAME

The height of the seed drill frame is adjusted in the seeding position using the lamellas turned onto the lifting cylinder arm so that the coulters have optimal movement ranges in the seeding position. The images below present dimensions for the correct seeding position of coulters.

- ⓘ In the seeding position, seed coulters must be raised by 50 mm from their lower position. In this case, the coulter is able optimally to follow any changes in the field surface and cross any obstacles. If the machine frame is adjusted too high, the coulter will not be able to follow any depressions in the field at the correct working depth. If the machine frame is adjusted too low, the movement range reserved to cross obstacles will be too small, and the coulter may be damaged when crossing high obstacles.

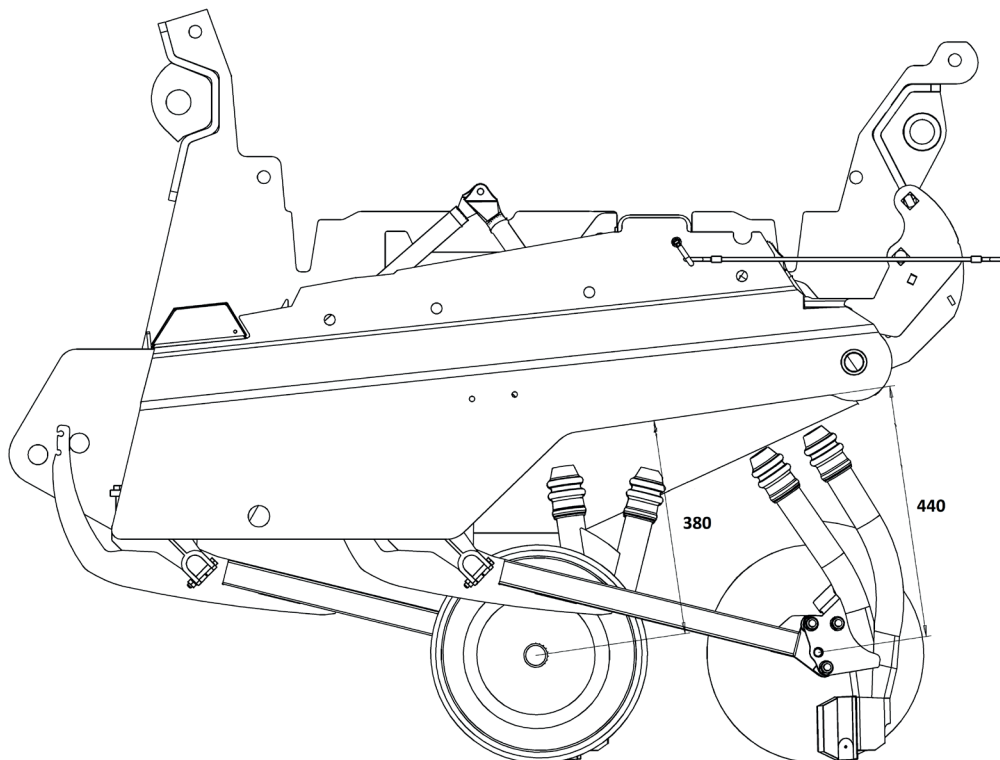

Picture 26. S-coulter raised 50 mm

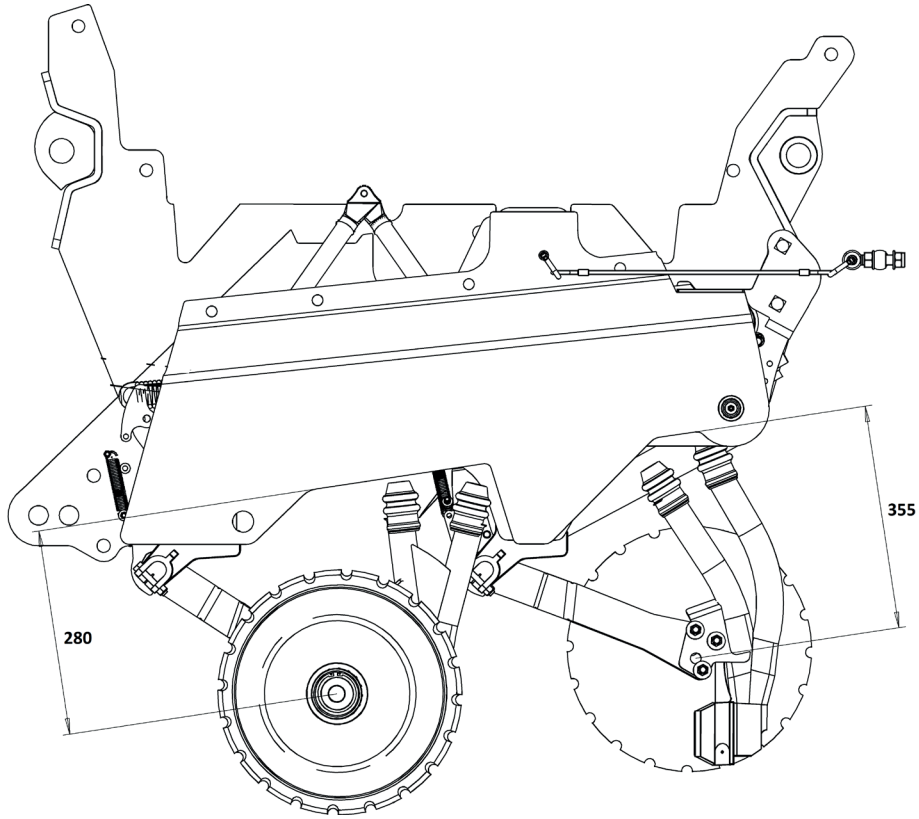

Picture 27. M-coultter raised 50 mm

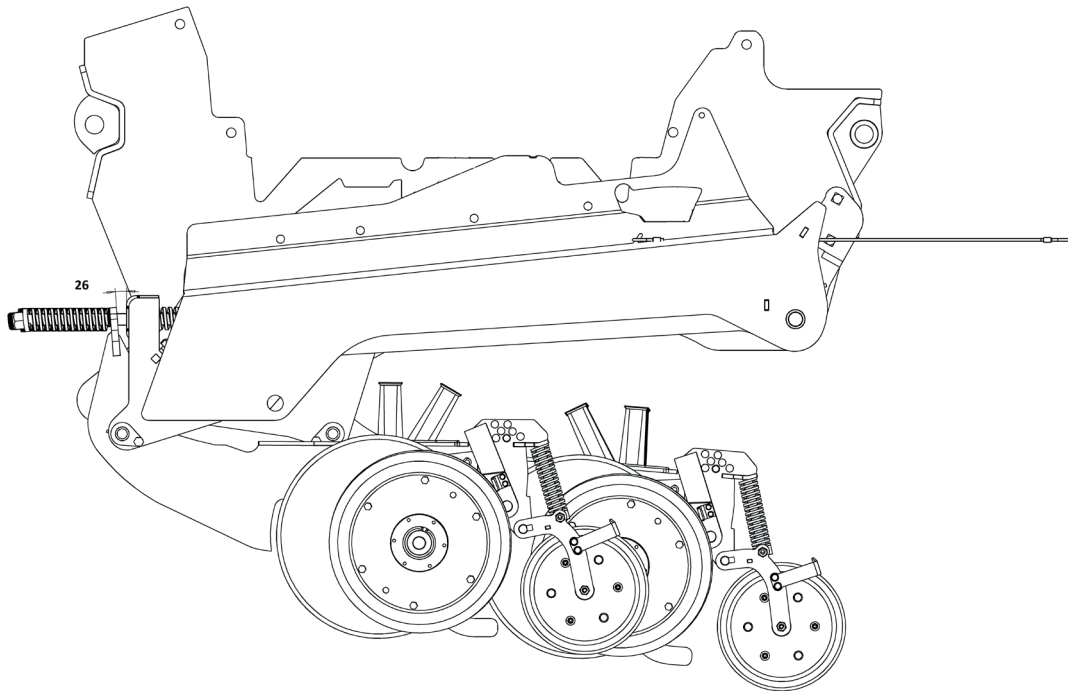

Picture 28. D-coultter raised 50 mm

CYLINDER AND LAMELLS

A table indicating the number of lamells placed onto the lifting cylinder at each seeding depth is presented below. The precise number of lamellas depends on how much the machine wheels sink into the ground.

When the machine is used for the first time, it should be pre-adjusted according to the table in advance, after which the frame height and coulter depth should be adjusted accurately in the field. The adjustment of the coulter pressurisation is described later in a section 6.6.

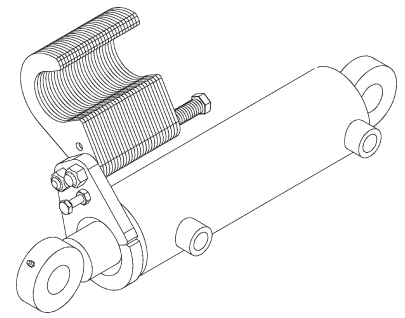

Picture 29. Cylinder and lamells

Lamells down (mm)						
	S-series		M-series		D-series	
Working depth mm	7.5 x 16 R	7.5 x 20 R	7.5 x 16 R	7.5 x 20 R	7.5 x 16 R	7.5 x 20 R
0	105	85	80	55	115	90
10	100	80	75	50	110	85
20	95	75	70	45	105	80
30	90	70	65	40	100	75
40	85	65	60	35	95	70
50	80	60	55	30	90	65
60	75	55	50	25	85	60
70	70	50	45	20	80	55
80	65	45	40	15	75	50

Table 7. The number of lamells placed onto the lifting cylinder at each seeding depth

6.4 HORIZONTAL MACHINE POSITION

Before adjusting horizontal position:

- **S- and M-series:** A study maintenance support must be placed under the frame fastening lug.
- **D-series:** Lower empty machine to the ground supported by its coulters.

Adjusting horizontal position:

The adjustment is made using the pushing arm located between the machine frame and drawbar when the machine is in the working position.

The machine is adjusted to be horizontal in the seeding position so that the coulter fastening beams in the frame are at the same level.

After the adjustment:

- **M - and D-series:** Pushing arms include locks that prevent the arms from moving while driving. Tighten the locks carefully after adjustments.

i The machine is adjusted to be horizontal in which case front and rear coulters seed at the same depth. If the working depth is changed significantly, it may be necessary to readjust the machine to be horizontal.

i The easiest way to verify whether or not the machine is horizontal is to place a bubble level on coulter beams. When adjusting the machine visually, the horizontal section of the rear rail attached to the end of the box can be used as a horizontal line in the rear.

! Note that the supporting bar at the end of the machine and the bending lines are not horizontal!

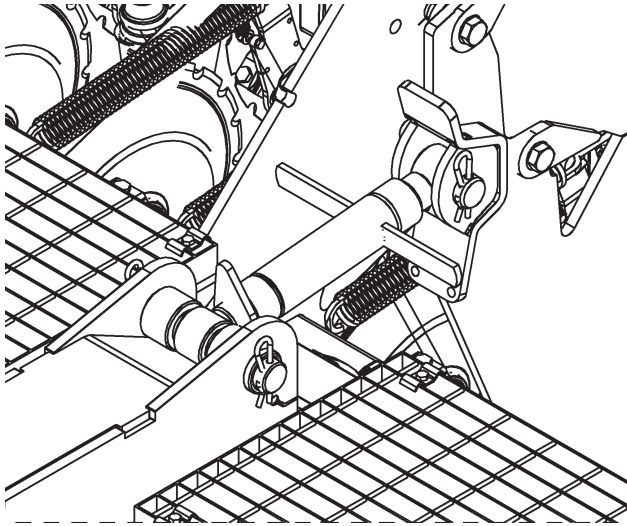

Picture 30. Pushing-arm in M-/D-series

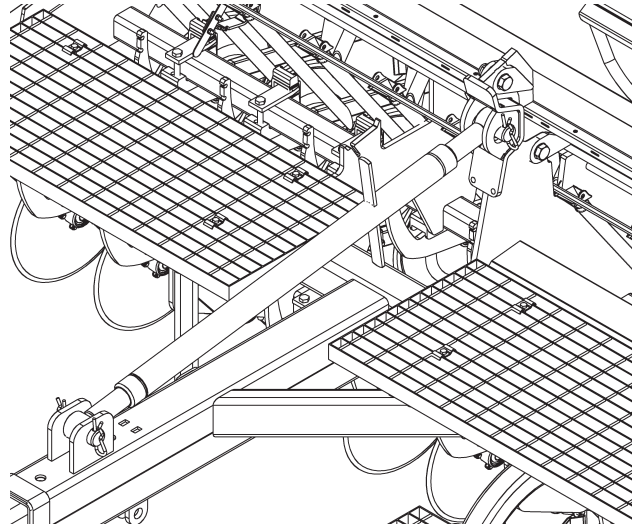

Picture 31. Pushing-arm in S-series

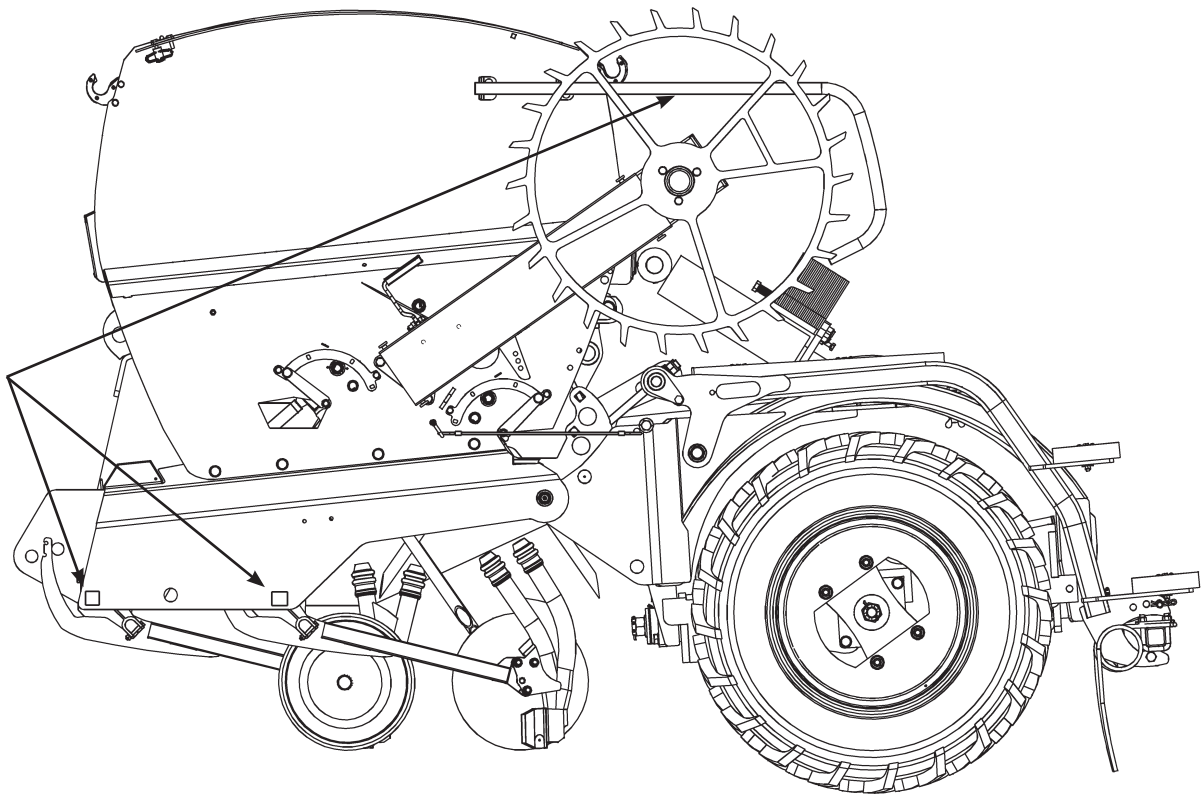

Picture 32. Horizontal machine lines (top surfaces of coulters beams, rail pipe)

6.5 FRICTION WHEEL



Make sure that your feet do not remain under the lowering friction wheel! The seed drill must be raised up when the friction wheel is lowered.

LOWERING THE FRICTION WHEEL

1. The seed drill must be raised up
2. Grab the extraction lever with your left hand and the lifting lever with your right hand.
3. Pull the extraction lever to turn the friction wheel outwards, while supporting and carefully lowering the wheel from the lifting lever.

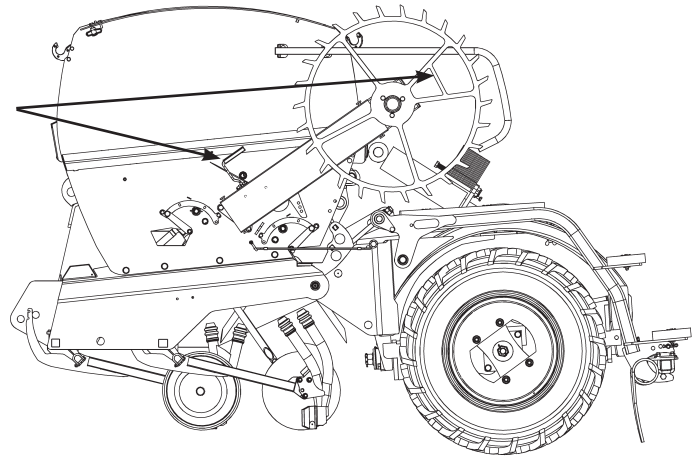

Picture 33. Lowering the friction wheel

ADJUSTING THE LIFTING HEIGHT OF THE FRICTION WHEEL

1. The lifting height of the friction wheel is adjusted using the threaded rod at the end of the lifting wire.

Check the adjustment when using a low lift and when switching between seeding depths.



The friction wheel should rise from the ground at the same time as the coulters do. It should also be checked that the friction wheel has a sufficient clearance downwards in the working position so that feeding works properly when the friction wheel falls into a hole.

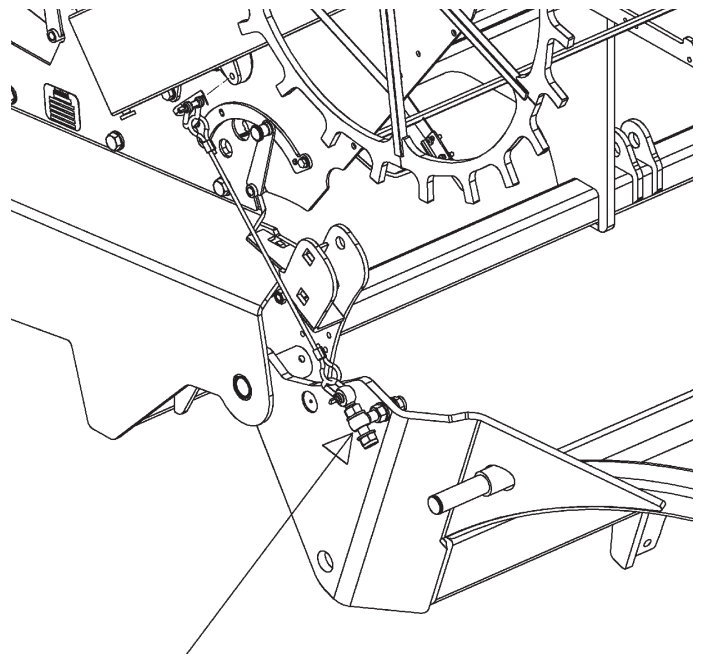

Picture 34. Adjusting the lifting height of the friction wheel

6.6 SEEDING DEPTH OF SEED COULTERS IN S-SERIES MACHINES

The correct working position of the coulter and frame ensures a successful seeding result and a sufficient coulter movement range when crossing obstacles. In a correctly adjusted machine, the coulter has risen 50 mm from its lower position to the seeding position.

The coulter pressure in the S-series can be adjusted up to 30 kg. As optional equipment, the coulter weight can also be adjusted hydraulically.

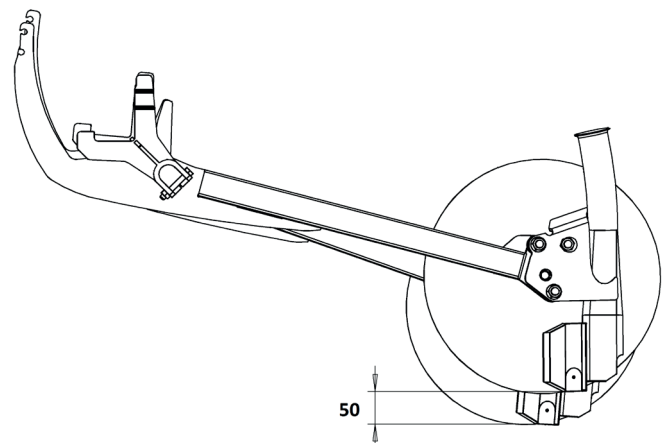

Picture 35. S-series coulter in rest/seeding position



Before any seeding, larger rocks and other significant obstacles must be collected so that they can be avoided. If obstacles are crossed carelessly, the coulters, wheels or other machine structures might be damaged.

6.6.1 MECHANICAL ADJUSTMENT OF THE COULTER PRESSURE



Always use the cylinder maintenance support when performing adjustments or maintenance.

The coulters pressures of seed coulters in the S-series are adjusted collectively in their separate blocks on both sides of the machine. The coulters pressure in the S-series can be adjusted up to 30 kg.

1. The adjustment is made by turning the left and right adjustment rods using the calibration lever at the rear of the machine.

The scale located next to the rod indicates the position of the adjustment.



Never set the coulters pressure lower than zero because the coulters pressurisation springs might be damaged during seeding.

6.6.2 HYDRAULIC ADJUSTMENT OF THE COULTER PRESSURE

The hydraulic adjustment of the coulters pressure is made using the tractor's double-acting hydraulics. The adjustment indicator is in the front wall of the hopper.

When the seed drill is disconnected from the tractor, the coulters pressure should be adjusted to its minimum value. In this case, the hydraulic system will be depressurised, allowing hoses to be connected or disconnected more easily.

6.6.3 COULTER-SPECIFIC ADJUSTMENT AND SEEDING DEPTH

If the coulters weight is to be set at a different tightness on a coulters-specific basis in S-series machines, the slots in the pressurisation spring in the front of the coulters arm can be used.

1. To adjust the coulters pressure, the central adjustment must temporarily be loosened so that the springs are sufficiently loose to make the adjustment.

S coulters pressure, mechanical

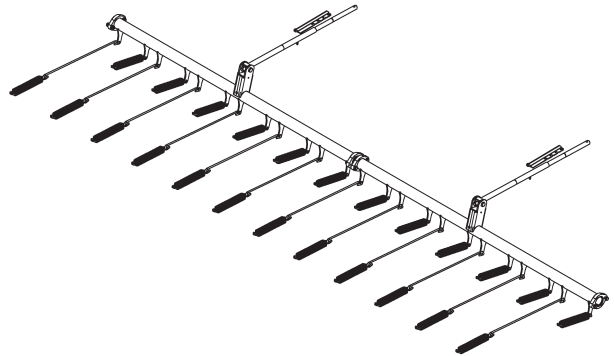
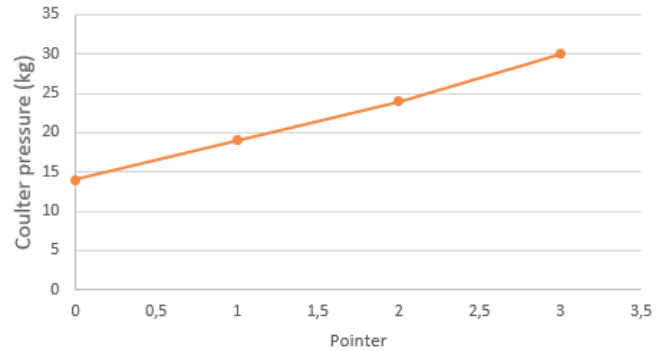

Picture 38. Mechanical coulters pressure

S coulters pressure, hydraulic

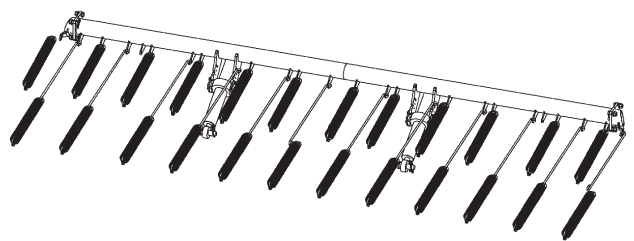
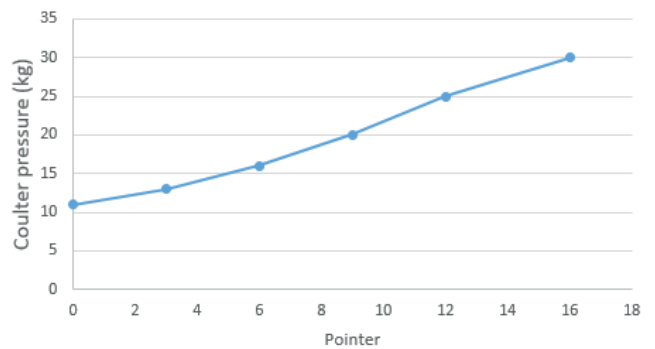

Picture 36. Hydraulic coulters pressure

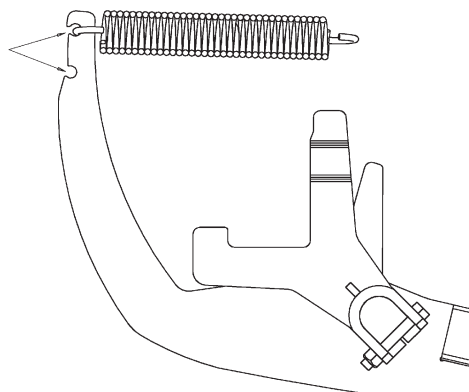

Picture 37. Coulters specific adjustment of the spring

2. If the coulter weight is to be set at a different tightness on a coulter-specific basis in S-series machines, the slots in the pressurisation spring in the front of the coulter arm can be used.

In the upper slot, the coulter pressure is tighter and, in the lower slot, it is looser.

3. Remember to return the coulter pressure once the springs have been adjusted.

- i** Check the seeding depth in the field using the depth gauge delivered with the machine and, if required, adjust the frame height and coulter pressure
- i** During spring seeding and in particularly dry conditions, the optimal location of the seed is between the cultivated and uncultivated layers, in which case moisture rises to the seed from the uncultivated layer through capillary action. The cultivated layer breaks the action, thus protecting the soil from evaporation. Avoid any unnecessarily deep cultivation. During autumn seeding and in wet conditions, deeper seeding and cultivation improve the ability of the soil to accept moisture.

6.7 WORKING DEPTH OF FERTILISER COULTERS IN S-SERIES MACHINES

Junkkari S-series machines can be equipped with separate fertiliser coulters at the acquisition stage to apply fertilisers into the ground between seed rows at a row interval of 250 mm. Fertiliser coulters have been designed so that fertilisers are applied 20 mm deeper than seed rows. There is no separate depth adjustment for fertiliser coulters. Their depth is determined according to the height of the seed drill frame.

FERTILISER COULTER OPTIONS

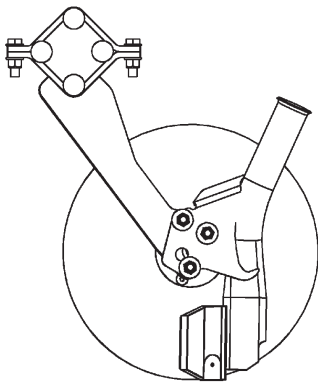

Picture 39. Rubber stick fertiliser coulter

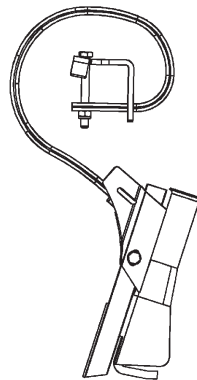

Picture 40. S-tine fertiliser coulter

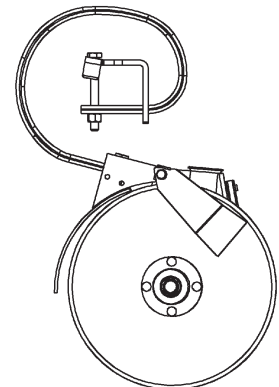

Picture 41. Double-disc fertiliser coulter

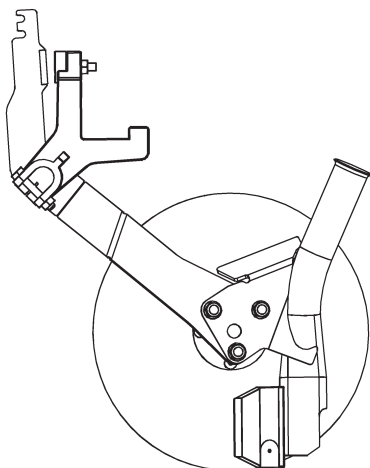

Picture 42. S-series fertiliser coulter

6.8 SEEDING DEPTH OF SEED COULTERS IN M-SERIES MACHINES

In Junkkari M-series machines, the coulters pressure is adjusted hydraulically as standard. The hydraulic adjustment is made using the tractor's double-acting hydraulics. The adjustment indicator is in the front wall of the hopper. The coulters pressure can be set between 30 and 100 kg.

The correct working position of the coulters and frame secures a successful seeding result and a sufficient coulters movement range when crossing obstacles. In a correctly adjusted machine, the coulters has risen 50 mm from its lower position to the seeding position.

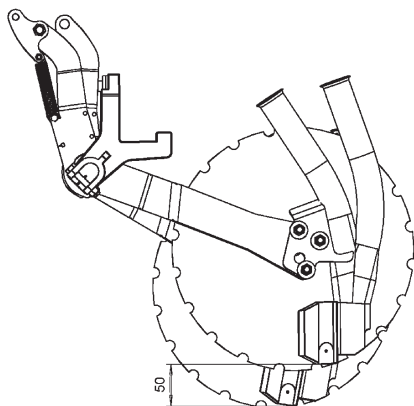
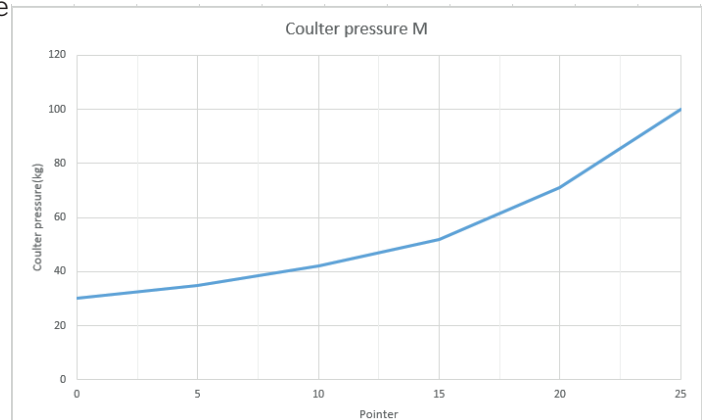

Picture 44. M-series coulters in rest/seeding position

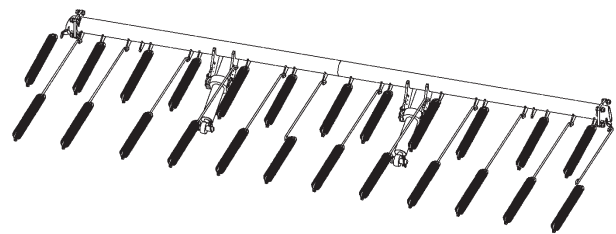

Picture 43. Hydraulic coulters pressure



Before any seeding, larger rocks and other significant obstacles must be collected so that they can be avoided. If obstacles are crossed carelessly, the coulters, wheels or other machine structures might be damaged.



Check the seeding depth in the field using the depth gauge delivered with the machine and, if required, adjust the frame height and coulters pressure.



During spring seeding and in particularly dry conditions, the optimal location of the seed is between the cultivated and uncultivated layers, in which case moisture rises to the seed from the uncultivated layer through capillary action. The cultivated layer breaks the action and, thus, protects the soil from evaporation. Avoid any unnecessarily deep cultivation. During autumn seeding and in wet conditions, deeper seeding and cultivation improve the ability of the soil to accept moisture.



When the seed drill is disconnected from the tractor, the coulters pressure should be adjusted to its minimum value. In this case, the hydraulic system will be depressurised, allowing hoses to be connected or disconnected more easily.

6.9 WORKING DEPTH OF FERTILISER COULTERS IN M-SERIES MACHINES

Junkkari M-series machines can be equipped with separate fertiliser coulters at the acquisition stage to apply fertilisers into the ground between seed rows at a row interval of 250 mm. The depth of fertiliser coulters is adjusted using the adjustment rods in front of the drawbar. They are rotated using the calibration lever.



The final adjustment of fertiliser coulters should be checked after the correct frame height has been adjusted because the machine frame height adjustment has an influence on the working depth of the fertiliser coulters.

6.10 COULTER SIDE PLATE IN S- AND M-SERIES MACHINES

The side plate is suspended by three bolts, with spring washers pressing the side plate against the coulters disc. By tightening the nut, the side plate is pressed more tightly against the disc.

1. The gap between the disc and side plate should be adjusted so that the side plate is in contact with the disc in point A. There should be a small gap in points B and C. (Picture 45)

! If the side plate is adjusted incorrectly, plant waste may accumulate in the gap.

! The side plate should be tightened so that it is pressed lightly against the disc. If the nuts are too tight, the wear of the disc and side plate and the disc's rotating resistance will increase. When seeding in very soft conditions or at a low depth, it may be necessary to loosen the nuts.

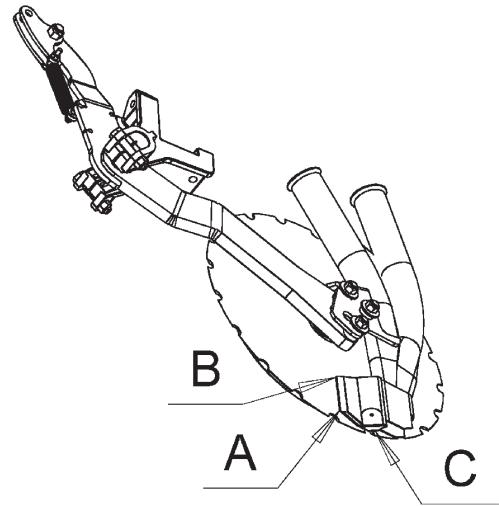

Picture 45. Assembled coulters

6.11 SEEDING DEPTH AND PRESS WHEEL IN D-SERIES MACHINES

ADJUSTMENT OF THE DEPTH CONTROL WHEEL

In the D-series, the coulters seeding depth is adjusted for each coulters by adjusting the height of the depth control wheel. Adjust the height of the wheel by changing the position of the stopper pin at the back of the arm. Release the pin by turning it half a turn and pulling it out.

i The seeding depth can be adjusted between 1 and 7 cm at 1 cm intervals. For pin locations and corresponding seeding depths, see Pictures 48 and 49.

ADJUSTMENT OF THE COULTERS PRESSURE

Hydraulic coulters pressurisation consists of two hoses: pressure and return. Connect the pressure hose to the tractor's valve block and the return line preferably to a free return connection. If no return connection is free, connect this line to the valve block, from which pressure is fed. Activate coulters pressurisation by switching on a continuous flow from the tractor block to the pressure line. The flow can be adjusted to be relatively low (5–15 l/min) to prevent oil from overheating. Pressure in the coulters pressurisation line is adjusted by an electric 3-way pressure reducing valve, which returns any excess oil back into the tank. The pressure gauge indicates the pressure in the coulters pressurisation line. The maximum coulters pressure of 250 kg can be achieved.

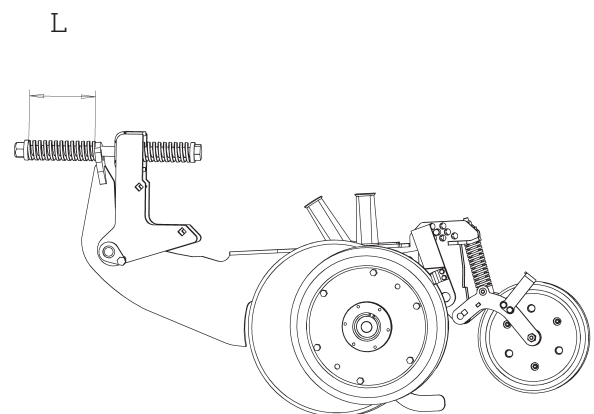

Picture 46. Measuring the spring

ved when the system is adjusted to a pressure of 80 bar.

NOTE: Do not adjust the pressure higher than 80 bar.



Before any seeding, larger rocks and other significant obstacles must be collected so that they can be avoided. If obstacles are crossed carelessly, the coulters, wheels or other machine structures might be damaged.

The correct working position of the coulter and frame secures a successful seeding result and a sufficient coulter movement range when crossing obstacles. In a correctly adjusted machine, the coulter has risen 50 mm from its lower position to the seeding position, and the coulter weight is sufficient to keep the depth wheel to its stopper.

Adjusting the compression force of the Adjust the compression force of the press wheel by changing the pre-tightening of the press wheel's pressurisation spring by moving the pin in the spring control shaft.

i If required, you can adjust the press wheel's lowering height by changing the position of the control shaft.



Observe special caution during transportation, when crossing obstacles in the field and when reversing to prevent the lowering press wheel from being damaged.



Only adjust the seeding depth and coulter pressure when the machine is raised. Always use the cylinder maintenance support when performing adjustments or maintenance to eliminate the crushing hazard.

Pressure spring length (mm)	Coulter pressure (kg)
178	50
176	54
174	63
172	72
170	80
168	87
166	98
164	104
162	112
160	122
158	130
156	140
154	148
152	158
150	180
148	190
146	202
144	209
142	220

Table 8. Coulter weights corresponding to spring pre-tightening lengths in the seeding position

6.12 TRACKMARKER

ADJUSTING THE PLOUGHING ANGLE

1. The ploughing aggression of the trackmarker disc can be adjusted by loosening the shaft bolt nut and turning the shaft.
2. After loosening, hit the end of the shaft lightly using an impact tool to detach the cone which unlocks the position from its lock.

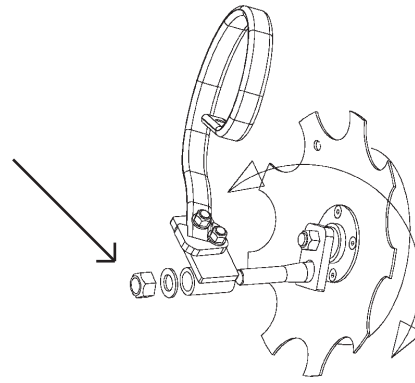

Picture 47. Adjusting the ploughing angle

THE LATERAL POSITION

1. The trackmarker position is measured from the middle of the drawbar or machine frame.
2. The lateral position of the trackmarker is adjusted by moving the spring fastener position along the marker pipe. (Picture 49)



Picture 48. The lateral position

i Depending on the working width, the dimension must be 3,000 mm in 3-metre machines and 4,000 mm in 4-metre machines.

The position of the trackmarker line can easily be checked in the field by driving the machine along a straight line with the markers down and by measuring the dimension between the outermost seeding row and the line drawn by the marker. Correct dimensions are presented in table 9.

i The position of the trackmarker line can easily be checked in the field by driving the machine along a straight line with the markers down and by measuring the dimension between the outermost seeding row and the line drawn by the marker. Correct dimensions are presented in table 9.

3. Check the fastening of the trackmarker spring after a few operating hours.



Note that the machine must travel behind the tractor on the centre line so that the line drawn by the trackmarker guides the driving line in the correct position. If required, check packer alignment on the tractor's centre line in Section 6.2. Errors may also be caused if the driver is not seated in the middle of the tractor. There may also be driver-specific differences in the track line.

S / M 300	1560 mm
S / M 400	2060 mm
D 300	1580 mm
D 400	2080 mm

Table 9. Correct dimensions

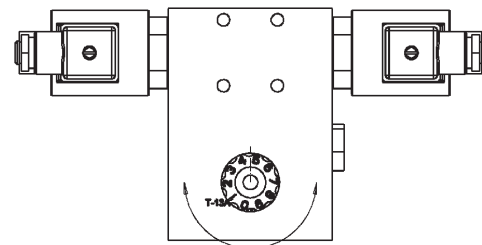

Picture 49. The rising speed

THE RISING SPEED

This adjustment is necessary because there are significant differences in the hydraulic output of tractors.

1. The rising speed of the trackmarker is adjusted from the valve in the rear of the drawbar using the flow adjustment knob. (Picture 50)
2. The rising speed is adjusted so that, when rising, the marker does not collide with its upper stopper with unnecessarily high force.
3. Always lock the markers in their upper position during transportation, maintenance and storage. (Picture 51)

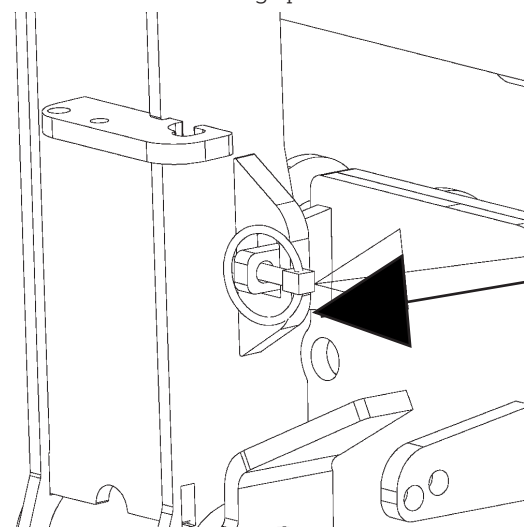

Picture 50. Markers lock

6.13 FOLLOWING HARROW

Harrow tines have been divided so that they are located between seed rows. Harrow tines act on the centre line of the wheel and between the wheels. The purpose of the harrow is to loosen the topsoil rolled by the wheels so that rainwater can better penetrate the surface. The loose soil also forms a layer which slows down evaporation. The harrow also raises larger soil particles that form the least crust in the rain to the surface.

ADJUSTING THE WORKING HEIGHT OF THE HARROW

The working height of the harrow is adjusted by changing the position of the nut on the threaded rod at the top of the harrow arm.

ADJUSTING THE AGGRESSION OF THE HARROW

The aggression of harrow tines is adjusted using the pins at the lower end of the harrow arms.

i If the ground does not need to be harrowed aggressively, the harrow should be adjusted in a fairly low-gradient position so that it can better penetrate any plant waste and does not lift seeds to the surface, even when turning.

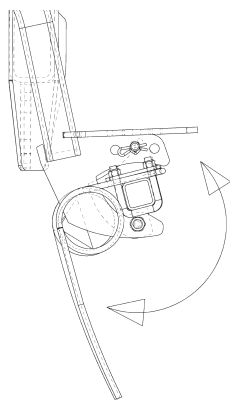

Picture 51. Adjusting the aggression of the harrow

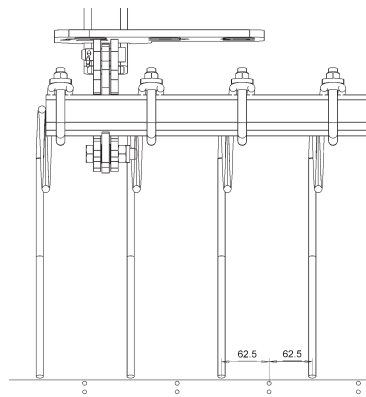

Picture 52. Harrow location between seed rows

6.13.1 HALF LIFT OF THE HARROW (S- AND M-SERIES)

Machine half lift is available for S- and M-series machines as optional equipment. When activated, machine lifting will be stopped automatically when coulters and the friction wheel are slightly off the ground. The harrow will remain on ground and boundary strips can be harrowed. As a result, the risk of crust rainwater puddle formation can be reduced in boundary strips.

ADJUSTING THE LIFT HEIGHT

The machine half lift height is adjusted by adjusting the lifting sensor in the rear corner on the left side of the machine close to the pivot point of rolling wheels.

To adjust the lift height:

- If the half lift height is to be increased, lower the sensor.
- If the half lift height is to be reduced, raise the sensor.



Before reversing, lift the machine fully up.



Turn of the seed drills control unit before adjusting the lifting sensor.



Note that, when making the basic adjustment of the half lift function, it may also be necessary to adjust the lifting height of the friction wheel or the height adjustment of the harrow.

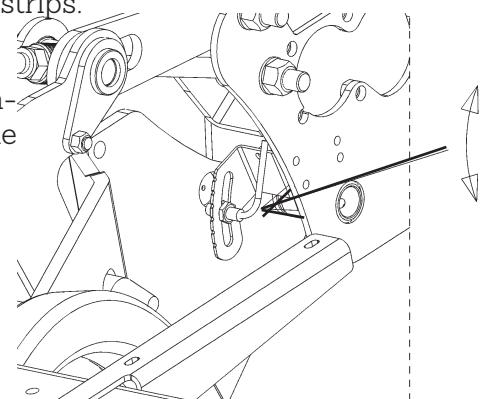

Picture 53. Adjusting half lift

6.14 HOPPER ROLL COVER

Roll covers for Junkkari seed drills are manually rolled or spring-rolled, depending on the hopper size. Regardless of the rolling mechanism, cover adjustments are similar.

⚠ Always make sure that the cover cord does not hang inside the hopper so that it could twist around the mixer axle or feeding roll and damage the machine!

! Always keep the cover closed because any moisture or dust in the fertiliser interferes with the operation of the seed drill..

SELECTING THE ROLLING POSITION

The cover rolling position can be selected to be in the middle above the hopper wall or in the leading edge of the hopper (Picture 55). The rolling position is determined using the middle cover fasteners on top of the end curves of the hopper. The middle fastener can be installed in different positions in the middle of the hopper according to the box wall position. The fastener can also be installed to the leading edge of the cover, in which case the cover is fully rolled in the front. The cover is locked from the front and rear using the locking mechanism located in the middle.

1. Open the lock by pressing the tube acting as the cover handle downwards, while releasing the lock with your thumb. (Picture 56)

i The supporting hooks located at the ends of the machine support the frame pipe so that it can also be used as a handle. The locking and supporting hooks must be adjusted so that, when closed, the cover tightens slightly.

2. The fastener position can be changed by loosening the finger screws located below the box end curve when the cover is closed.

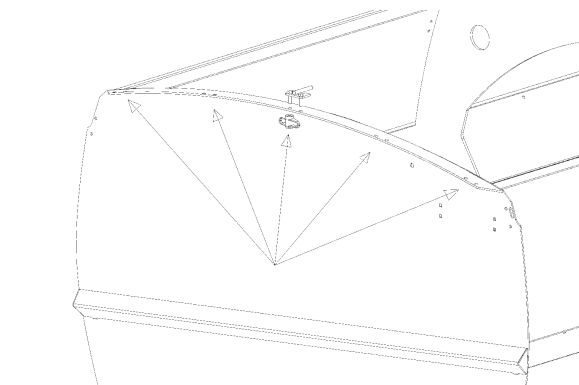

Picture 54. Selecting the rolling position

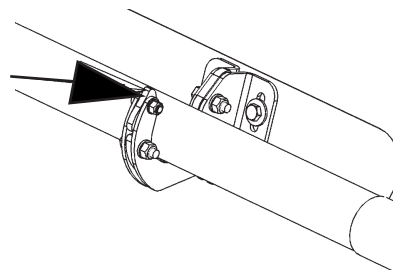

Picture 55. The cover lock

6.15 FEEDING MECHANISM

The feeding mechanism is an integral part of the metering device. The feed rate of all Junkkari feeding mechanisms is continuously adjusted by the metering devices gearbox by adjusting the rotation speed of the feed axis. The gearboxes are protected by mechanical freewheel switches to prevent the gearbox from rotating wrongway.

The metering device consists of the following parts:

- Feed chamber
- Cover and overflow hatch
- Feed roll
- Bottom flap
- Switch valve
- Closing hatch

6.15.1 METERING DEVICE FOR SEEDS AND FERTILISER

The feed rolls of the metering device for fertilisers are of the rifle type. A double-studded roll is used for seeds with a yellow small seed roll and a black regular roll.

- When applying small seeds, the narrow small seed roll is used. In this case, the red locking pin is turned to the left through the overflow hatch, which releases the traction of the black roll and locks it into place.
- When applying regular seeds, both studded rolls are used. In this case, the metering device cover is opened and the locking pin is turned to its extreme position on the right, after which both rolls turn freely

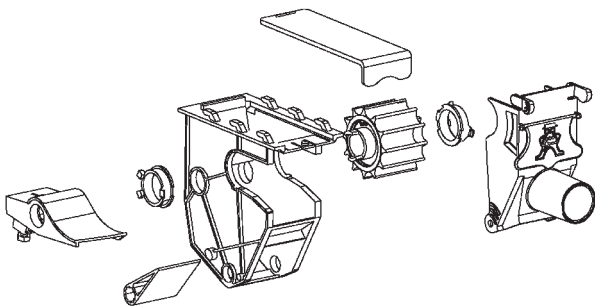

Picture 56. Metering device for fertiliser

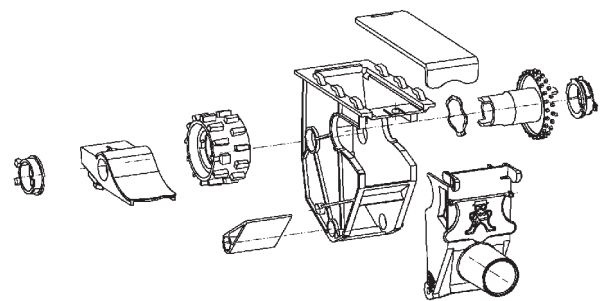

Picture 57. Metering device for seeds

CLICKING OF THE LOCKING PIN

When moving the locking pin, make sure that it moves all the way to its extreme position. If the locking pin does not move to its extreme right position, turn the black studded roll one tooth in either direction and turn the pin again.

ⓘ A half released feed roll may damage the metering device.

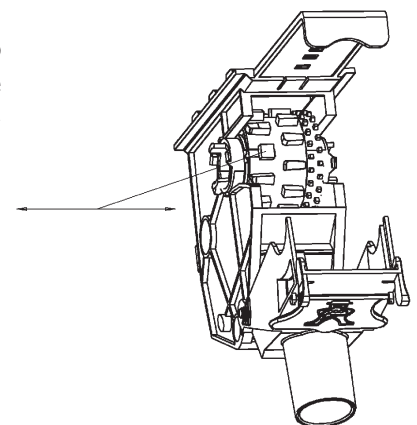

Picture 58. Clicking the locking pin

6.15.2 CLEANING THE FEED ROLL

The interior of the feed roll should be cleaned during the seeding period using compressed air. It should especially be cleaned if the locking pin is difficult to move or there are impurities inside the black roll. (Picture 60.)

6.15.3 ADJUSTING THE BOTTOM FLAP

In the feed chamber, there is a curved bottom flap under the feed roll. Its tightness is controlled from the two levers located underneath the feeding mechanism. The lever adjustment affects the left and right bottom flaps. The bottom flap is spring-loaded and yields slightly if a foreign object or a fertiliser lump enters the feeding mechanism.

When using regular grained fertilisers, the tightness of the bottom flap is set at adjustment slot 1 which is the second tightest position. If a coarser fertiliser is used, the bottom flap must be set to be looser. The tightness of the bottom flap in the metering device for seeds must be adjusted according to the seed size as shown in the table 10. The table is also located in the seeding table at the end of the machine.

6.15.4 SWITCH VALVE POSITIONS

The switch valve guides the material flow to coulters or the calibration tray. In addition, the valve is used to select the seeding of small seeds to the surface or through coulters. The switch valve positions are selected separately for fertiliser and seed sides using the control handles at the end of the machine on the left. (Picture 61 and Table 11.)

6.15.5 CLOSING HATCH

There is a closing hatch between the feed chamber and hopper. If required, this can be used to close seed or fertiliser feeding separately from each metering device. When open, the closing hatch must always be fully open to ensure the even feeding of material. If you are feeding particularly large seeds, such as broad bean or pea, the closing hatch should be removed.

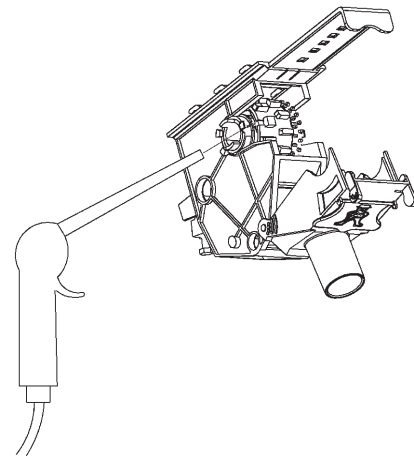

Picture 59. Cleaning the feed roll

Switching valve	Grain size
0	Small seed
1	Cereals, fertilise
2	Pea
3	Horsebean

Table 10. Switching valve positions

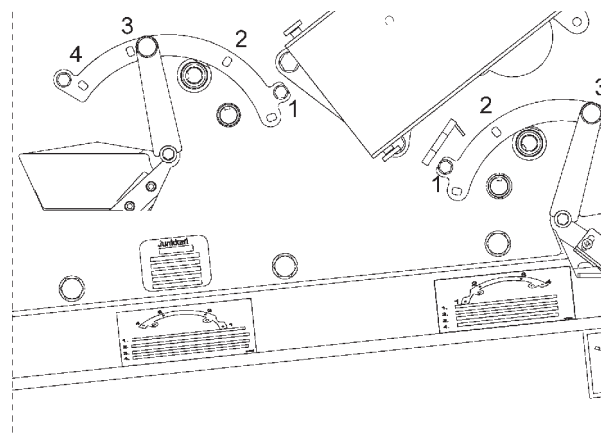

Picture 60. Switch valve positions and handles

Kuva 1. Picture 65. Closing hatch

Position	Function	Description	Notice
1	Seeds or fertilisers left in the machine can be emptied into calibration trays.	The bottom flap can be turned fully open so that small volumes of material can be drained easily into the calibration tray.	Large volumes of seeds or fertilisers can be drained onto the ground through coulters when the switch valve is in position 3.
2	Calibration.	Seeds and fertilisers are drained in calibration trays installed next to the metering devices.	The small seed device is calibrated with the switch valve in position 3.
3	Regular seeding.	Seeds or fertilisers are forwarded from the metering device to coulters. Material from the small seed device is drained onto the ground randomly.	
3	Small seed device calibration.		Seeds and fertilisers are drained in calibration trays installed next to the metering devices.
3	Emptying the machine.	The content of the hopper flows freely onto the ground.	Turn the switch valve to position 3 and fully open the bottom flap.
4	Regular seeding and start-fertilizing	Material from the metering device flows to coulters. Seeds or starter fertilisers from the small seed device also flow to coulters on the same seeding row.	

Table 11. Switching valve positions and functions

6.15.5 CLOSING HATCH

There is a closing hatch between the feed chamber and hopper. If required, it can be used to close seed or fertiliser feeding separately from each metering device. When open, the closing hatch must always be fully open to ensure the even feeding of material.

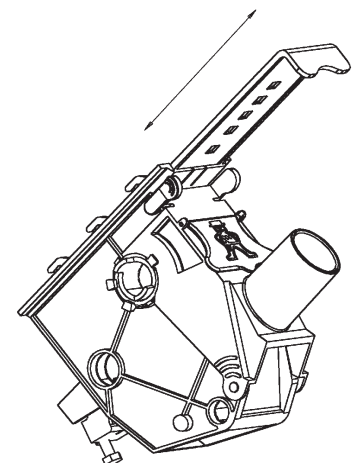

Picture 2. Closing hatch

7 CALIBRATION AND DEFINING THE SEEDING VOLUME

Calibration is a requirement for successful seeding. A seeding table is located at the end of the seed drill box which indicates example values for seeding volume adjustments. However, there are significant differences in seeds in terms of size, weight and flow, because of which the actual seeding volume must be verified through calibration.

Seeded plants have recommended seeding densities that are affected by the field's soil type and growing and moisture conditions. In general, the seeding volume is increased slightly in situations where germination conditions have deteriorated due to draught or poor growing conditions.

! Always make sure that the seed is pure and germinating. Impure seeds may cause blockage in the seed drill, or even damage.

Calculating the seeding volume

- The seeding volume can be calculated by multiplying the weight of one thousand seeds in grams by the seeding density and by dividing the result with the germinating percentage:

$$\text{Seed rate (kg/ha)} = \frac{\text{Thousand seed weight (g)} \times \text{density (kpl/m}^2\text{)}}{\text{germinating \%}}$$

- The targeted seeding volume can also be indicated in units. A single unit refers to one milling germinating seeds. In this case, the seeding volume is calculated by multiplying the unit weight by the targeted unit volume:

$$\text{Seed rate (kg/ha)} = \text{Unit weight (kg/unit)} \times \text{Volume (unit/ha)}$$

! When performing the calibration, remember to deduct the weight of the weighing bag from the weighing result.

i When calibrating the small seed/starter box available as additional equipment, seeds are drained through the actual seed metering device into calibration trays so that the switch valve is set to position 3.

7.1 CALIBRATION USING A MANUAL VOLUME CONTROL

1. Make sure that the bottom flap is adjusted according to the tightness presented in the seeding table.
2. Turn the volume control switch of the gearbox to the position indicated in the seeding table.
3. Turn the switch valve to calibration position 2.
 - If you are calibrating the small seed/starter box, turn the seed side's switch valve to position 3 so that the material can be drained into the calibration tray.
4. Place calibration trays in their holders next to the metering device.
 - When calibrating the small seed/starter box, place the trays in their holders next to the actual seed metering device.
5. Attach the calibration lever to the calibration shaft of the gearbox and rotate it until seeds or fertilisers come evenly out from all metering devices. Empty the tray.
6. Perform a rotating calibration into the trays.

i The seeding table indicates the number of rotations depending on the width of the machine. The arrow next to the gearbox shaft indicates the direction of rotation. Make sure that identical piles are fed from metering devices into the calibration trays. For example, if small volumes of small seeds are applied, double the volume should be rotated into the trays in order to get a more accurate weighing result. Then, divide the weighing result by two.

7. Weigh the calibrated volume and adjust the gearbox.

i A one-hectare seed volume can be calculated by multiplying the weighing result by one hundred (e.g. 3.50 kg refers to 350 kg/hectare). Remember to deduct the weight of the weighing bag from the result. Repeat the calibration as many times as needed until the targeted seeding volume is reached.

8. Turn the switch valve to seeding position 3 or 4 as necessary.

9. Place the calibration lever and trays into their storage positions.

The calibration should be repeated after a few hectares because, due to machine vibration, seeds and fertilisers are packed more densely in the hopper, causing the feeding volume to increase slightly.

7.2 CALIBRATION USING AN ELECTRONIC VOLUME CONTROL

Depending on the control unit, an electronic volume control for seeds and fertilisers is available for Junkkari seed drills as optional equipment. This allows the seeding volume to be adjusted while driving using the seed drill control unit. The calibration of a new machine should be repeated at least four times if the basic factory setting differs significantly from the calibration result. The adjustment accuracy of the electronic cylinder is 0.7 mm.

1. Switch on the seed drill control unit and select calibration from the menu.

The control unit requests for an average fertiliser/seed volume.

i For example, if you wish to apply 200–400 kg/hectare of fertilisers, set 300 kg/hectare as the average volume. As a result, the calibration will be performed with the setting of 300 kg/hectare.

2. After confirming the average seeding volume, the control unit adjusts the electronic cylinder according to the setting of 300 kg/hectare and enters the calibration result feeding mode where the calibration can be performed.

3. Make sure that the bottom valve is adjusted according to the tightness presented in the seeding table.

4. Turn the switch valve to calibration position 2.

If you are calibrating the small seed/starter box, turn the seed side's switch valve to position 3 so that the material can be drained into the calibration tray.

5. Place calibration trays in their holders next to the metering device.

When calibrating the small seed/starter box, place the trays in their holders next to the actual seed metering device.

6. Attach the calibration lever to the calibration shaft of the gearbox and rotate it until seeds or fertilisers come evenly out from all metering devices. Empty the trays.

7. Perform a rotating calibration into the trays.

i The seeding table indicates the number of rotations depending on the width of the machine. The arrow next to the shaft indicates the direction of rotation. Make sure that identical piles are fed from metering devices into the calibration trays. For example, if small volumes of small seeds are applied, double the volume should be rotated into the trays in order to get a more accurate weighing result. Then, divide the weighing result by two.

8. Weigh the result. Remember to deduct the weight of the weighing bag from the result.

9. Enter the result in the control unit and confirm any corrections.

Note that the weighing result of the calibration is entered directly in the control unit in kilograms. Do not enter kg/hectare.

10. Repeat the calibration and make sure that the targeted seeding volume is reached. If the result differs from the target value, enter the result in the control unit to correct the result.
11. Turn the switch valve to seeding position 3 or 4 as necessary.
12. Place the calibration lever and trays into their storage positions.

The calibration should be repeated after a few hectares because, due to machine vibration, seeds and fertilisers are packed more densely in the hopper, causing the feeding volume to increase slightly.

7.3 CALIBRATION BY DRIVING

In some situations where a specifically accurate calibration is required, it should be performed by driving. Calibration by driving takes into account any slippage of the friction wheel and changes in feeding caused by machine vibration. Note that, when driving, all gearboxes will rotate. If required, feeding can be stopped using closing hatches.

1. Perform a regular calibration while standing still as described above, and adjust the seed drill's seeding volume.
2. Leave the seed drill ready for calibration (switch valve, calibration tray).
3. Lower the friction wheel.
4. Measure a driving distance corresponding to a seeding area of 100 m².
 - i This is 33.3 m for three-metre machines and 25 m for four-meter machines.
5. Make sure that metering device are full of seeds by rotating the friction wheel.
6. Drive the measured distance with the machine down. After driving, make sure that even piles have flown from metering devices into the calibration trays.
 - i If the targeted seeding volume is low, drive a double distance to ensure a more accurate weighing result. Then, divide the weighing result by two.
7. Weigh the calibrated volume and adjust the gearbox.
 - i A one-hectare seed volume can be calculated by multiplying the weighing result by one hundred (e.g. 3.50 kg refers to 350 kg/hectare). Remember to deduct the weight of the weighing bag from the result. If required, repeat the calibration.
8. Turn the switch valve to seeding position 3 or 4 as necessary.
9. Return the calibration trays into their storage positions.

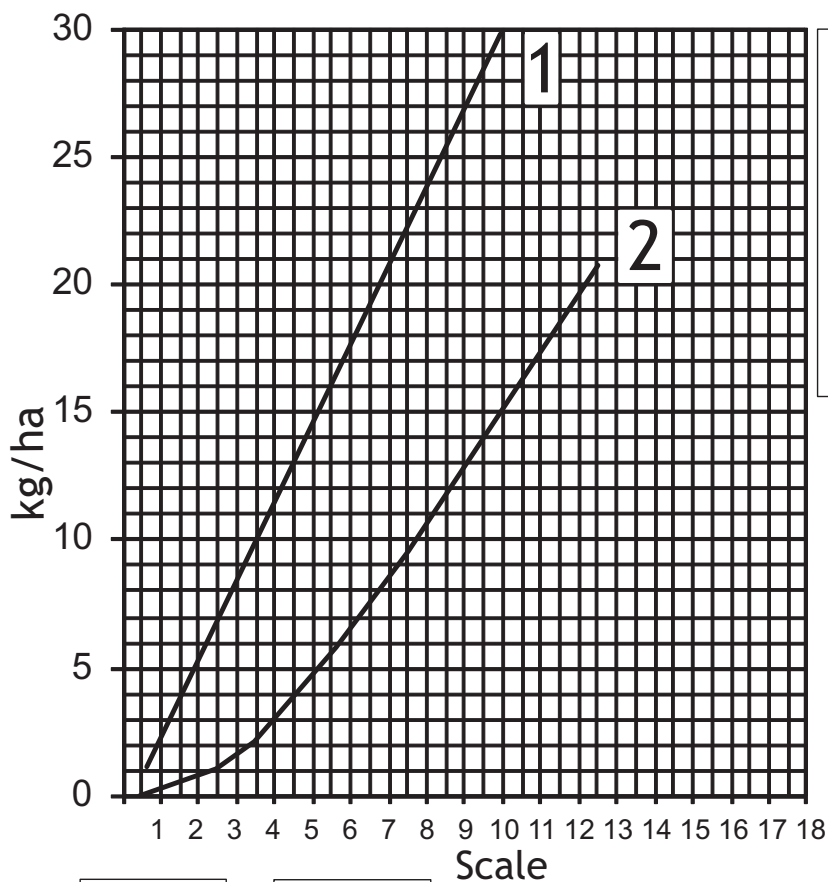

S300
M300 **29r/100m²**
D300

S400
M400 **22r/100m²**
D400

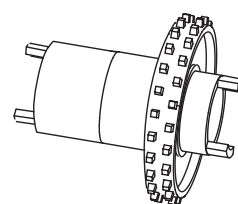

POHJALÄPÄN ASENNOT
BOTTENKLÄFFENS LÄGE
POSITION OF THE BOTTOM FLAP
BODENKLAPPEN STELLUNG
POSITION DU LEVIER INFÉRIEUR
POSIZIONE LEVA INFERIORE

Rypsi
Rybs
1

Rapsi
Raps
Rape
Colza
2

0	1	2	4	1
PIENSIEMEN SMÅFRÖ SMALL SEED KLEINSAMEN PETITES GRAINENS SEME PICCOLO	VILJA SPANNMÅL GRAIN SEEDS GETREIDE GRAINS CEREALI	HERNE ÄRTER PEAS ERBSEN POIS PISELLI	HÄRKÄPAPU BÖNER BEANS BOHNEN HARICOTS FAGIOLI	LANNOITE GÖDSEL FERTILIZER DÜNGER ENGRAINS FERTILIZZANTE

33248

SMD PSL

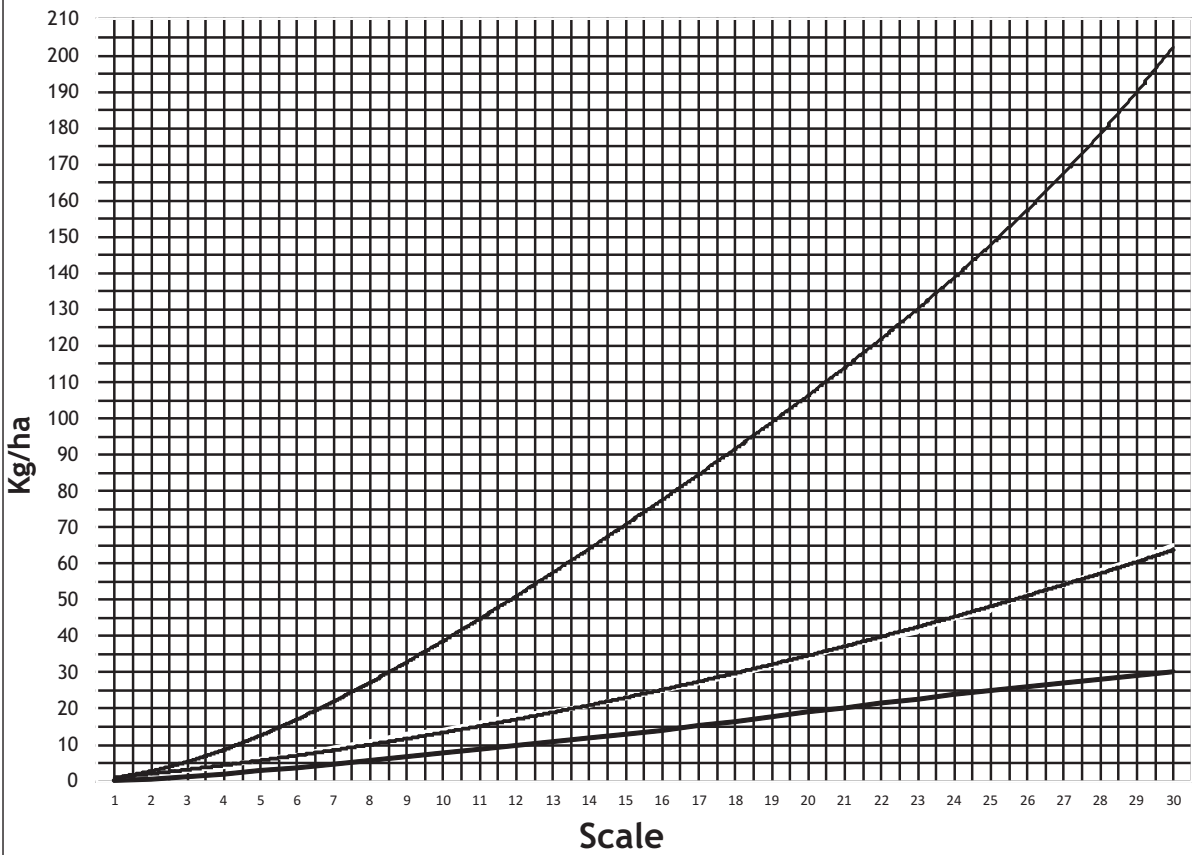

- 1** Startti P
Start P
Start P
Dünger P
engrais P
- 2** Nurminata
Ängssvigel
Grass
Gras
Herbes
Timotei
Timotej
Timothy
Lieschgras
Fléole
- 3** Apila
Klöver
Clover
Klee
Tréfle
- 3** Raiheinä
Rajgräs
Ryegrass
Weildergras
Ivraie

SMD 300 29r / 100m ² SMD 400 22r / 100m ²	POHJALÄPÄN ASENNOT BOTTENKLAFFENS LÄGE POSITION OF THE BOTTOM FLAP BODENKLAPPEN STELLUNG POSITION DU LEVIER INFÉRIEUR	0
--	---	---

33663

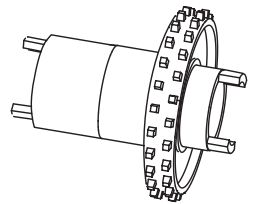

8 TRAMLINES

As optional equipment, Junkkari seed drills can be equipped with tramline clutches controlled using the G-Wizard or ISOBUS control unit. Tramlines facilitate spraying and reduces the trampling effect. This results in more even growth.

There are three ways to drive tramlines:

- **Symmetrical:** It is the simplest way and suitable for the most common seed drill-spray combinations. In a symmetrical tramline, the sprayer tramline is in the middle of the seeding line.
- **Asymmetrical on the left and right side of the seed drill:** In the asymmetrical method, a single set of tramlines is driven twice, in which case the centre line of the track is in the middle of the seeding lines.

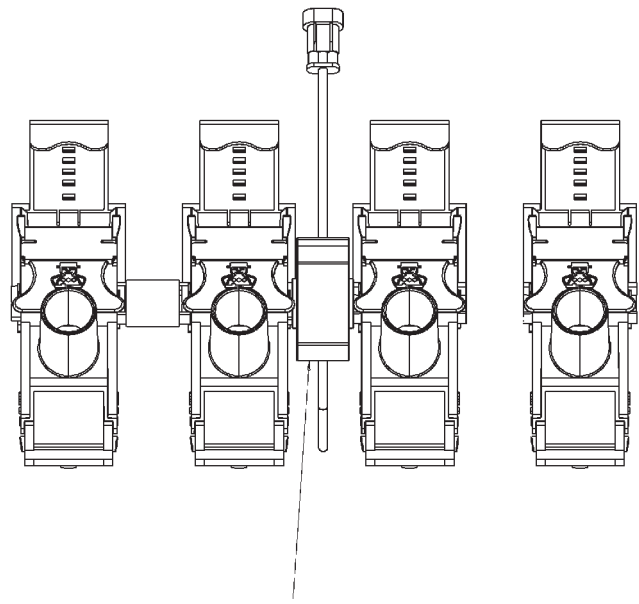

Picture 3. Tramlines clutch

SEED LINE AND SPRAYING

When using tramlines, the driving method must be planned so that tramlines are suitable for spraying.

Easiest method:

1. Circle the field so many times that a single set of tramlines are made around the field.
2. Once tramlines have been driven at the edges of the field, drive a few times in boundary strips if required to turn in boundary strips.
3. Once the boundary strips are long enough for turning, start going back and forth in order to utilise the control unit's automatic calculator.

i A simple figure of seeding on tramlines where the driver has first drive around the field three times, after which the driver has driven back and forth, is presented in picture 64.

i The width of the plant protection sprayer is five times the width of the seed drill. For example, a four-metre machine has a 20-metre sprayer.

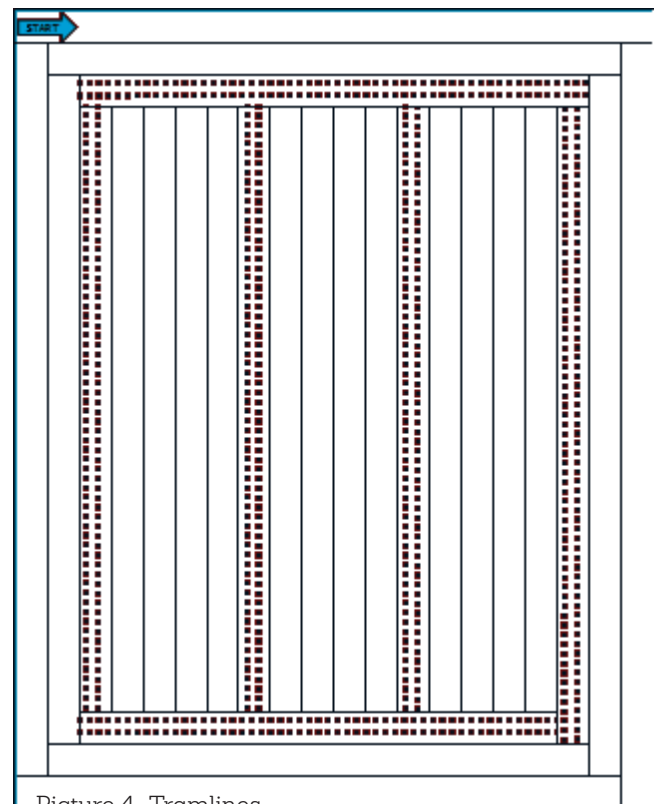

Picture 4. Tramlines

Drill width (m)	Sprayer width (m)	Tramline rhythm	Tramline counter start value	Notice
3 m	12 m	4	2	First round sown with half machine width
	15 m	5	3	
	18 m	6	3	First round sown with half machine width
	21 m	7	4	
	24 m	8	4	First round sown with half machine width
	27 m	9	5	
	30 m	10	5	First round sown with half machine width
	33 m	11	6	
	36 m	12	6	First round sown with half machine width
4 m	12 m	3	2	
	16 m	4	3	First round sown with half machine width
	20 m	5	3	
	24 m	6	4	First round sown with half machine width
	28 m	7	4	
	32 m	8	5	First round sown with half machine width
	36 m	9	5	
	40 m	10	6	First round sown with half machine width

Table 12. Sprayer width and symmetrical tramlines

8.1 SYMMETRICAL TRAMLINES

Tramlines are driven symmetrically so that, during marking, feeding is stopped next to both tyres of the spraying tractor. The table 12 presents how tramlines can be driven symmetrically for different sprayer widths using three- and four-meter seed drills.

During the first round, feeding is closed using the half machine stopper available as additional equipment or by closing the closing hatches of metering devices on one side of the machine. Remember to return the machine's working width back to normal after the first round. (Picture 65.)

8.2 ASYMMETRICAL TRAMLINES ON THE LEFT SIDE OF THE SEED DRILL

Tramlines are driven asymmetrically on the left side of the seed drill so that, during marking, seed drill feeding is stopped on the left side for two consecutive rounds. The asymmetrical method can be used when the spray width is an even number times the width of the seed drill. When using asymmetrical tracks, the half machine setting can be avoided during the first round. The table 13 presents how tramlines can be driven asymmetrically for different sprayer widths using three- and four-meter seed drills.

Drill width (m)	Sprayer width (m)	Tramline rhythm	Tramline counter start value
3 m	12 m	4	3
	18 m	6	4
	24 m	8	5
	30 m	10	6
	36 m	12	7
4 m	16	4	3
	24	6	4
	32	8	5
	40	10	6

Table 13. Sprayer width and asymmetrical tramlines

- ⓘ Note that the location of the tramline clutch usually differs according to the type of driving method.
- ⓘ Also note that, when using asymmetrical tramlines, the seed drill's automatic half lift function cannot be used.

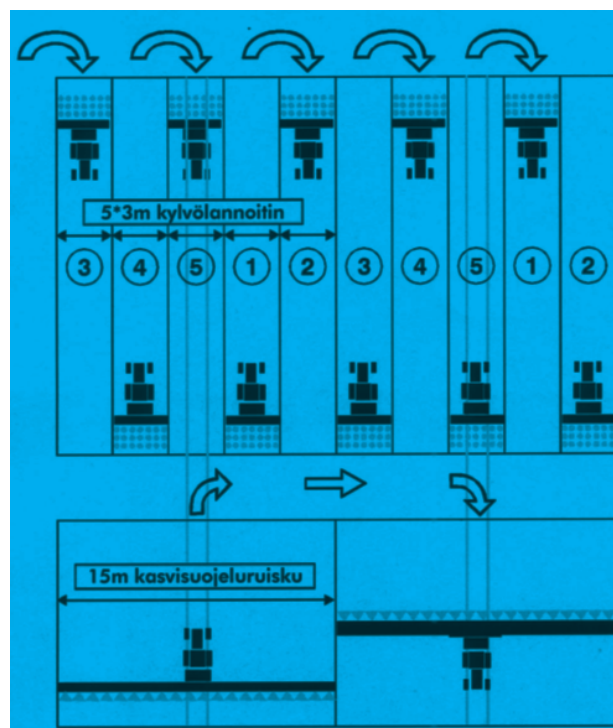

Picture 5. Symmetrical tramlines

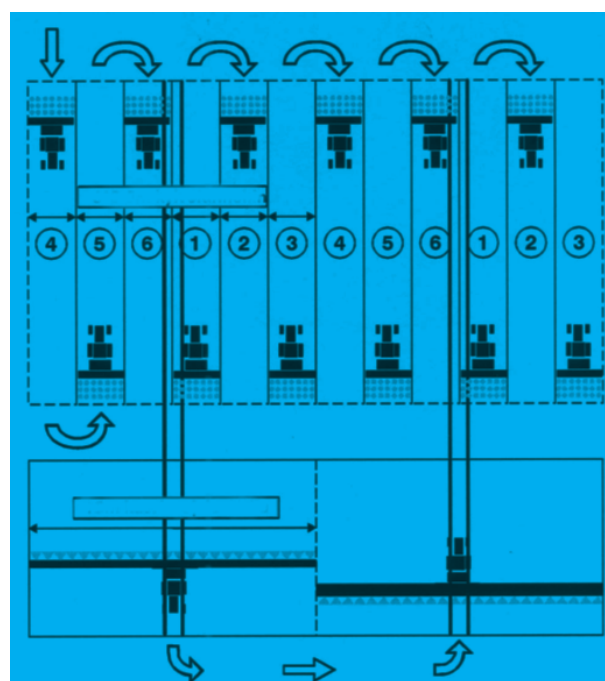

Picture 6. Asymmetrical tramlines (left)

8.3 ASYMMETRICAL TRAMLINES ON THE RIGHT SIDE OF THE SEED DRILL

When driving asymmetrical tramlines on the right side of the seed drill, the procedure is similar to driving asymmetrical tramlines on the left, except the clutch to be stopped is on the right side of the machine. The side selected depends on the driving direction during the first round. The picture 67 illustrates how tramlines are driven on the right side.

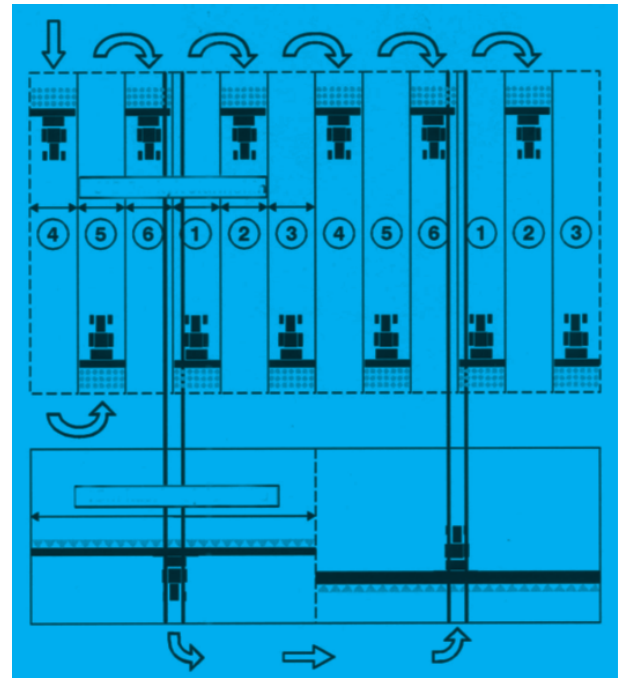

Picture 7. Asymmetrical tramlines (right)

Table 14. Speed multiplier table

9 SURFACE AREA METER

9.1 TECHNICAL SPECIFICATIONS

Display	4 digits
Power supply	2 x 1,5 V (AA battery)
Temperature limits	-10°C - +70°C (may vary depending on the battery type)
Pulses from the sensor	max. 167 pulse per second
Min. pulse-time	0,6 ms
Internal memory	Speed ratio, width and 2 area counters saved
Other	Splash water protected

Table 16. Area meter technical specifications

9.2 GENERAL

The surface area meter calculates the surface area on the basis of the travelled distance indicated by the speed sensor and the machine width entered in the meter. The speed multiplier (symbol o on the screen) refers to the distance (cm) travelled between two pulses sent by the speed sensor.

- If the surface area meter is installed at the Junkkari factory, the speed multiplier (symbol o on the screen) and the machine's working width (symbol |---|) have already been set, and the user does not need to change them. If the surface area meter is installed afterwards, the setting values are presented in the table 16.

Variable	Symbol	SMD400	SMD300
Speed multiplier	o	56.00	56.00
Working width	---	4.00	3.00

If the speed multiplier table does not offer the correct result, it is easy to fix. For example, if the actual surface area is 4.0 hectares and the meter indicates 4.4 hectares, multiply the speed multiplier value by 0.90 (90%) and enter the adjusted speed multiplier in the meter.

9.3 USING THE SURFACE AREA METER

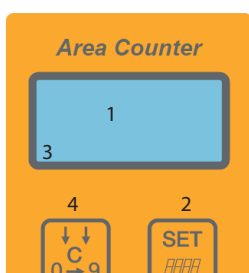

Number	Part	Function	Instruction
1	Display		
2	SET-button	Start-up	Press button
		Activate the change function	
		Resetting speed multiplier and work width	
		PA-counter reset	Press SET , until PA parameter flashes, then press C -button
3	Left segment	While getting speed pulses the lower "bar" of the first digit will flash during work	
4	C-button / F-button	Start-up	Press button
		Change of active parameter displayed	Look section 9.4
		Turning off	Press button until you see text STOP
		Moving from one function to other	F.2 -> HA.1 -> HA.2 -> --- -> o
5	Cable and speed sensor	Speed input to counter.	

9.4 CHANGING AND RESETTING VALUES

The surface area meter speed multiplier **o** and work width **|---|** values can be changed and the values of the counters **HA.1** and **HA.2** can only be reset.

CHANGE THE SPEED MULTIPLIER

1. Press **C**-button until the speed multiplier symbol **o** and values appear.
2. Press **SET**-button for two seconds.
Dot starts to blink on the screen.
3. Press the **C**-button to move the point to the desired position.
4. Press the **SET**-button repeatedly until the number you want to change starts blinking.
5. Press **C-button** to change the number until the

Table 17.Surface area meter parts and functions

number is correct.

6. Repeat steps 4-5 as many times until the value is correct.
7. Finally, press the **SET**-button until you see the symbol **o**.

Speed multiplier has been saved.

SURFACE COUNTERS RESET

The surface area meter has two different area counters **HA.1** and **HA.2**, both of those can be reseted.

HA.1 reset

1. Press the **C**-button until **HA.1** and the accumulated surface reading appear.
2. Press **SET**-button for two seconds.
Surface reading blinks on the screen.
3. Press **C**-button to reset the area.
4. Press **SET**-button until you see symbol **HA.1**.

HA.2 reset

HA.2 is reset by providing security code **236** :

1. Press the **C**-button until **HA.2** and the accumulated surface reading appear.
2. Press **SET**-button until first digit starts to blink.
3. Press **C**-button until the first digit is the first digit of security code.
4. Repeat steps 2-3 until **HA.2**:n security code **236** has been added.
5. Press **SET**-button to reset the area.

The area meter goes out of the programming mode if any buttons are not pressed for 10 seconds.

9.5 TURNING THE AREA COUNTER OFF

- ⓘ The area meter can be switched off by pressing the **C**-button until **STOP** is displayed.
- The meter restarts if it receives speed pulses or if you press the **C** or **SET**-button.
 - If the area counter within a period of ½ hour has not received any pulse or key-press signals, the computer is automatically set in stop-mode.
 - The values of the area counters remain in memory even when the device is switched off..
- ⓘ If batteries are removed without turning off the area meter, the counter values will reset .

9.6 POWER SUPPLY

- The Area Counter must be supplied with power from 2 1,5V AA-batteries.

- When the Area Counter is re-started having been in stop-mode, the display first shows the version number of the specific computer.
- The computer then checks the power level - if this is too low the display shows '-bL'. If the Area Counter is then automatically turned off, the batteries must be changed.
- If the power supply from the batteries is too low the computer will occasionally flash the '-bL-' message during use. The batteries must then be changed, as counting errors may occur

ⓘ Remove the surface area meter batteries during winter storage.

9.7 INSTALLING THE SENSOR AND MAGNET

- Position of the speed sensor at the right end of the machine.

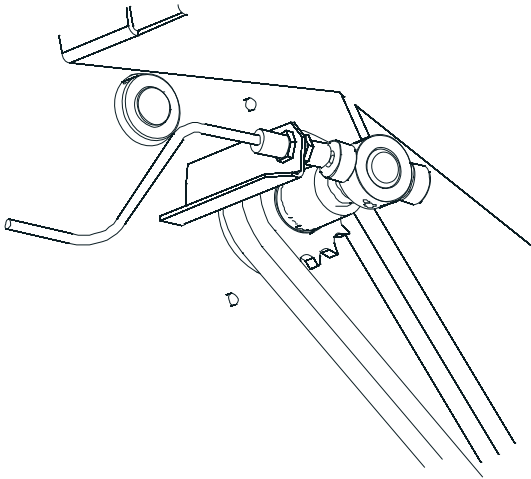

Picture 8. Installing the speed sensor

10 G-WIZARD

10.1 GENERAL

The G-Wizard control unit measures or monitors:

- Surface area (total area and two resettable calculators)
- Driving speed (km/h)
- Average seeded area per hour (ha/h)
- Shaft rotation
- Tramline switch operation
- Gearbox operation
- Hopper level
- If required, it can be used to diagnose and test sensor operations

The G-Wizard control unit controls or adjusts:

- The operation of trackmarkers manually or automatically
- The operation of tramline switches manually or automatically
- Machine half lift (additional equipment S/M)
- Fertiliser rate electronically (optional equipment)

MAIN TABS

The control unit screen includes four main tabs that can be browsed using the left shift -key.



The tab number is displayed in the tab key icon:

Driving tab

- The driving tab serves to control driving functions, such as trackmarkers, tramlines, fertiliser rate and half lift. Some of the functions displayed in the image are optional..

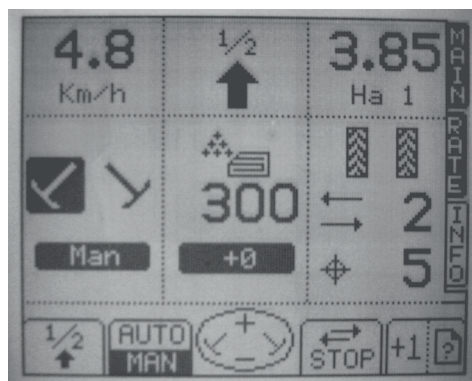

Picture 9. Driving tab

Machine guard tab

- Calibrate the seed metering device guard.
- Displays the rotating speeds of feed shafts.
- If the machine is equipped with an electronic remote control of fertiliser (G-Wizard Plus), you can also change the basic fertiliser rate setting



Picture 10. Machine guard

Calculator tab

- Total surface area and two resettable surface area calculators (HA.1 and HA.2).

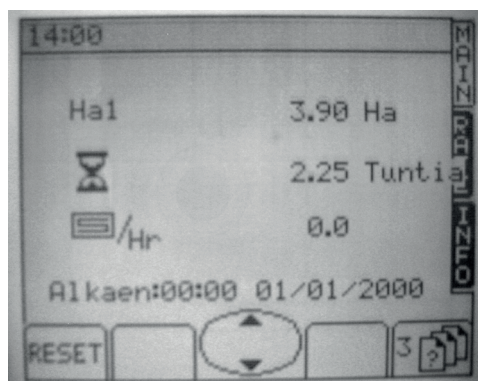

Picture 11. Calculator tab

Menu tab

- In the menu tab, you can perform a calibration (G-Wizard Plus), change settings and carry out diagnostics -functions.

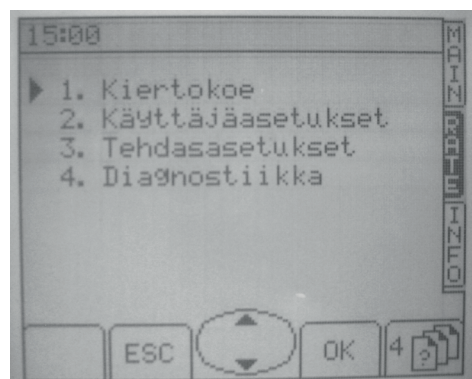

Picture 12. Menu tab

10.2 DRIVING MODE WITHOUT REMOTE FERTILISER CONTROL (G-WIZARD)

The appearance of the driving screen varies according to optional equipment selected. Depending on equipment, the screen displays the driving speed, half lift status, hectares driven, trackmarker status, average availability, tramline status and calculator value.







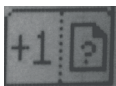
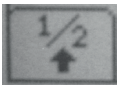

Buttons	Functions	Instructions
 Shift button	Browse four main tabs	<ul style="list-style-type: none"> To go directly to the driving tab, press the button for two seconds Press the button for three seconds to turn off the controller
 Half lift activation button	Activate or deactivate the half lift function	Always lift the machine up before reversing.
 Trackmarker control button  Trackmarker manual control button	Manual or automatic control of the trackmarker	<ul style="list-style-type: none">  The automatic function changes the trackmarker side automatically after lifting the machine. In the automatic mode, the trackmarker side can be changed when the machine is raised. Manual control, trackmarkers can be controlled as selected while driving. An active marker is highlighted on the screen.
 Calculator stop button	Tramline calculator stop button, trackmarker side change can be stopped	 This function is needed if the machine needs to be raised in the middle of a round.
 Tramline calculator	You can change the tramline calculator value.	

Table 15. Driving mode without remote control- buttons

10.3 DRIVING MODE WITH REMOTE FERTILISER CONTROL (G-WIZARD PLUS)

The appearance of the driving screen varies according to optional equipment selected. Depending on equipment, the screen displays the driving speed, half lift status, hectares driven, trackmarker status, fertiliser rate, tramline status and calculator value. Buttons and functions (Table 18).

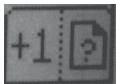
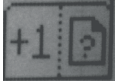
Buttons	Functions	Instructions
 Shift button	Browse four main tabs	<ul style="list-style-type: none"> • To go directly to the driving tab, press the button for two seconds • Press the button for three seconds to turn off the controller
 Trackmarker control button  Trackmarker manual control button	Manual or automatic control of the trackmarker	<ul style="list-style-type: none"> • The automatic function changes the trackmarker side automatically after lifting the machine. In the automatic mode, the trackmarker side can be changed when the machine is raised. • Manual control, trackmarkers can be controlled as selected while driving. • An active marker is highlighted on the screen.
 Fertiliser rate adjustment button	You can increase or reduce the fertiliser rate by the percentage defined in settings	<p>i For example: If the step is set at 10%, one push of the button will increase or reduce the fertiliser rate by 10%.</p> <p>When pressing “+” or “-” button 2s, the new basic fertilizer setting can be set using the arrow keys</p> <p>The change is accepted with the OK button. If you want to return to the driving tab without any changes, press the ESC button.</p>

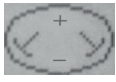
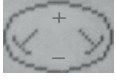



 <p>Calculator stop button</p>	<p>Tramline calculator stop button, trackmarker side change can be stopped</p>	<p> This function is needed if the machine needs to be raised in the middle of a round.</p> <p> The calculator should also be stopped when filling the machine.</p>
 <p>Tramline calculator</p>	<p>You can change the tramline calculator value</p>	
 <p>Half lift activation button</p>	<p>Activate or deactivate the half lift function</p>	<p> Always lift the machine up before reversing.</p>

Table 18. Driving mode with remote control- buttons

10.4 MACHINE GUARD

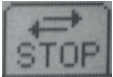
Buttons	Functions	Instructions
 <p>CAL-button</p>	<p>You can calibrate the rotating guard of the seed feeding mechanism if the seed shaft tramline clutches required have been installed in the machine.</p>	<ul style="list-style-type: none"> • The guard monitors the rotating ratio between the cardan shaft and the seed feed shaft. If the ratio changes, the guard gives an alarm. • At the factory, the change rate has been set at 35%. When the seed volume is changed, the rotating guard must be re-calibrated. • It is calibrated on the screen below while driving. When the ratio stabilises, press OK. After calibration, the calibration tab will be displayed.
 <p>SET-button</p>	<p>Change the basic fertiliser rate setting</p>	<ul style="list-style-type: none"> • Enter a new basic setting using the arrow keys and accept by pressing OK. Return without saving by pressing ESC.
 <p>Return button</p>	<p>You can return directly to the basic fertiliser rate setting if the fertiliser rate was changed on the driving screen using the + and - buttons.</p> <p>This tab also displays the rotating speed (revolutions per minute) of the seed and fertiliser feed shafts if tramline clutches have been installed in the shafts.</p>	

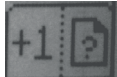
Table 19. Machine guard buttons and instructions

10.5 CALCULATORS

The calculator tab includes three calculators that measure the surface area and operating hours. Two of these calculators can be reset, whereas the third displays the machine's total surface area and operating hours.

Buttons	Functions
 RESET-button	You can reset the displayed calculator.

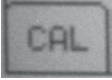
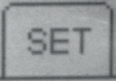
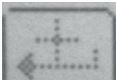
Table 20. Calculators buttons and functions

10.6 SETTINGS

In the settings tab, you can select four functions:

- Calibration (G-Wizard Plus)
- User settings
- Factory settings (The factory's PIN code required)
- Diagnostics

10.6.1 CALIBRATION (G-WIZARD PLUS)

Machines equipped with the electronic remote control of fertiliser as optional equipment are calibrated as described in this section. Instructions for the actual calibration are presented in Section 7 of this manual.

CALIBRATION

1. Select calibration from the settings tab

The control unit requests the average rate of fertiliser.

2. Press **SET**-button and set target rate.

For example: If 300–400 kg/hectare of fertiliser is applied, set 350 kg/hectare as the target rate. As a result, the calibration will be performed in the middle of the range to produce as accurate a result as possible.



3. Press **OK** to accept the target rate.

The machine will set the fertiliser rate according to the target rate based on the previous calibration.

4. Make calibration and enter the weighing result into the controller by using the arrow button.



Remember to deduct the weight of the weighing bag. Do not convert the result into kg/ha.



Press **ESC** to exit the calibration without saving any changes.

5. Press **OK** to accept the calibration result entered.

The control unit displays a summary of the calibration result.

Summary symbols

- **Previous refers:** The previous correction factor with which the curve illustrating the control unit's fertiliser feed rate is adjusted according to the nominal weight of fertiliser.
 - **New refers:** The new correction factor obtained through the calibration.
 - **Error:** Corrected by the calibration.
 - **Maximum:** The theoretical maximum fertiliser rate which can be applied using the machine.
6. Press **OK** to accept calibration changes or press **ESC** to cancel the calibration result and return to the settings tab without saving any changes.



It is recommended that changes are tested and a new calibration is performed. If a significant change in the feed rate is made in the calibration, the calibration should be repeated to make sure that the feed rate corresponds with the target rate. If required, enter any correction in the control unit as described above.

10.6.2 USER SETTINGS

See the user settings functions in the table 21.

Function	Description	Instructions
1. Screen	You can change the screen contrast and brightness	
2. Customisation	You can set the fertiliser rate step	<ul style="list-style-type: none"> The target value must be set as kg/ha, and the zero point offset and calibration offset must be set at 0.
3. Time/date	You can set the date and time	
4. Technical support	contact details of technical support.	
5. Language	You can change the control unit language	
6. Seed drill	You can define the seed drill width, set the speed sensor calibration factor manually or calibrate the speed sensor by driving.	<ul style="list-style-type: none"> By calibrating the speed sensor, you can improve the accuracy of the displayed speed and surface area. Due to different soil properties, the slippage and sinking of the friction wheel vary. In factory settings, the multiplier is 1.034. <p>Calibration</p> <ol style="list-style-type: none"> Measuring a distance of 100 metres in the field.. Drive the tractor to the starting marker and lower the machine and friction wheel to the ground. Start calibration by pressing OK. Drive to the finishing marker and press OK. Accept the calibration result by pressing OK or reject it by pressing ESC
7. Tramlines	You can edit tramline settings.	<ol style="list-style-type: none"> Change the width of the tramline interval by pressing up and down arrow keys. Use left and right arrow keys to change between symmetrical and asymmetrical driving methods. Confirm your changes by pressing OK. Press ESC if you wish to cancel your changes.
8. Alarm settings	<ul style="list-style-type: none"> Hopper level guard Axle alarm Gearbox alarm Speed alarm 	<p>i For example: if you are seeding small seeds or small amount of fertiliser, the alarm should be disabled.</p>
Table 21. User settings functions	<ul style="list-style-type: none"> Low voltage alarm 	

10.6.3 FACTORY SETTINGS

Factory settings can only be changed by persons authorised by the factory. As a result, factory settings can only be accessed by entering a PIN code.

10.6.4 DIAGNOSTICS

Using diagnostics, you can examine the operations of machine sensors. (Table 22.)

Function	Description
1. Device	<ul style="list-style-type: none"> • Displays: The control unit's supply voltage, • The voltage provided by hopper level guards. When the hopper is full, the voltage is 12 V. • The status of the machine lifting sensor.
2. Metering device	<ul style="list-style-type: none"> • Displays rotating speeds of the machine's speed sensor, seed shaft (if switches installed) and fertiliser shaft (if switches installed), and their corresponding sensor pulse frequencies. • The target length of the remote fertiliser control (optional equipment) and the measured length.
3. History	<ul style="list-style-type: none"> • Displays the machine's total hectares and operating hours.
4. Functioning testing	<ul style="list-style-type: none"> • Function testing to test machine sensors.

Table 22. Diagnostics functions

10.6.5 ALARM

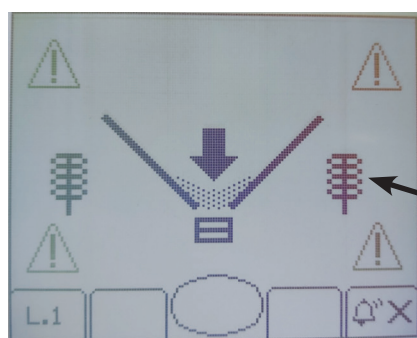

This **L.1** alarm means that the seed hopper is starting to run out of seeds. In other words, the seed level has dropped below the capacitive sensor.

The ear icon refers to the seed hopper.



This **L.2** alarm means that the fertiliser hopper is starting to run out of fertiliser. In other words, the fertiliser level has dropped below the capacitive sensor.

The fertiliser grain icon refers to the fertiliser hopper.

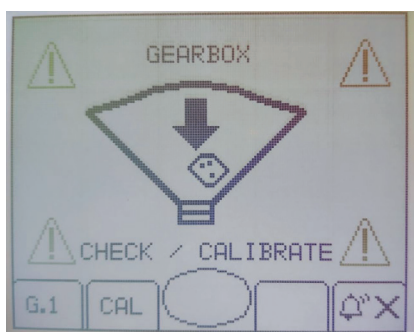

If the seed gearbox setting is changed by more than $\pm 25\%$, this image **G.1** will be shown on the main screen to indicate that the seed gearbox has not been calibrated. Calibration is carried out on screen page 2 using the CAL button during normal seeding.

If this alarm persists after calibration, check the condition of the seed gearbox as follows: Use the calibration lever to rotate the gearbox and check that the feed shaft rotates evenly.

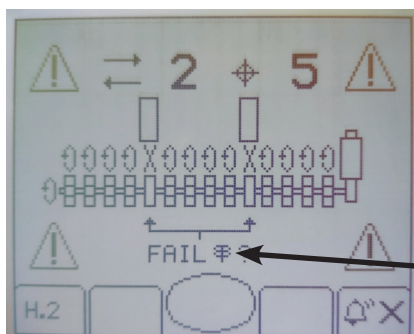

This **H.2** alarm means that speed pulses cannot be received from the seed shaft, even though the machine is in the seeding position and moves forward. Check the condition of the tramlines for seed on the left-hand side in the driving direction. You can also check whether pulses are even on screen page 4 under Diagnostics / Metering device.

The ear icon refers to the seed shaft.

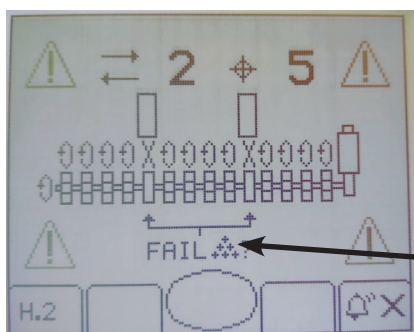

This **H.2** alarm means that speed pulses cannot be received from the fertiliser shaft, even though the machine is in the seeding position and moves forward. Check the condition of the tramlines for fertiliser on the right-hand side in the driving direction. You can also check whether pulses are even on screen page 4 under Diagnostics / Metering device.

The fertiliser grain icon refers to the fertiliser shaft.

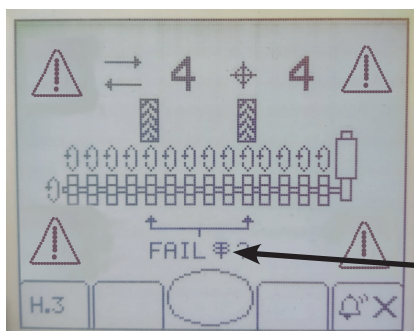

This **H.3** alarm means that the tramline clutch for seed does not work properly. In other words, the feeding rifles rotate even though they should be stopped. Check the power supply to the tramlines; when the tramline switches are energised, the switches produce a tramline, i.e., the feeding rifles next to the tramlines do not rotate.

The ear icon refers to the seed shaft.

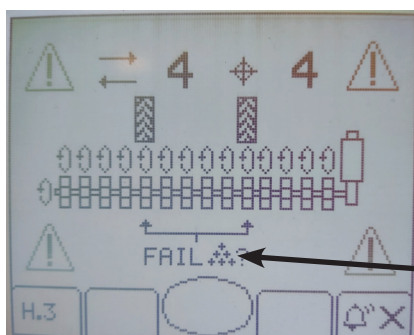

This **H.3** alarm means that the tramline for fertiliser does not work properly. In other words, the feeding rifles rotate even though they should be stopped. Check the power supply to the tramlines; when the tramline switches are energised, the switches produce a tramline, i.e., the feeding rifles next to the tramlines do not rotate.

The fertiliser grain icon refers to the fertiliser shaft.

11 JUNKKARI ISOBUS ECU TECHNICAL SPECIFICATIONS

Junkkari ISOBUS ECU is programmed in the 3724 control unit manufactured by EPEC Oy. The ISO-BUS functionality level is TC-GEO.



Picture 14. The ISOBUS cable of the seed drill and the plug on the tractor.

11.1 FUNCTIONS – JUNKKARI

1. Driving speed (km/h)
2. Surface area counter
 - The controller includes two resettable surface area counters that are shown on the main screen. In addition, a total surface area counter, which cannot be reset, is located behind the PIN code.
3. Tramline marker
 - Both symmetrical and asymmetrical tramlines can be produced.
4. Track marker
 - Can be used as an automated function so that the marker always changes side when the coulters are lifted/lowered. When operated manually, the selected coulters side always decreases when the coulters are lowered.
5. Pause
 - When this button is activated, the function disables the lifting/lowering sensor.
 - This function can be used if the coulters need to be lifted additionally for some reason and the rhythm of the tramline counter does not want to be changed.
 - Activate the pause function before lifting the coulters additionally and reactivate the counter by pressing the same button after the coulters have been lowered normally.
6. Fertiliser rate remote adjustment (optional equipment)
 - The fertiliser rate (kg/ha) can be adjusted from the controller; the desired adjustment can be selected between 1 and 99%. By default, the adjustment is 10%.
7. Seed rate remote adjustment (optional equipment)
 - The seed rate (kg/ha) can be adjusted from the controller; the desired adjustment can be selected between 1 and 99%. By default, the adjustment is 10%.

8. Pole lift
 - If the track marker needs to be lifted, while the coulters need to remain in the seeding position, the pole lift function can be activated.
9. Precision seeding
 - The controller is equipped with an ISOBUS TC-GEO function.
 - The machine's seed and fertiliser rate can be adjusted on a location-specific basis by using a pre-defined task. This requires that the position data is sent from the tractor to the CAN bus.
 - Junkkari ISOBUS can remotely adjust a total of four different materials.
 - For example, fertiliser, seed, small seed 1, and small seed 2. In other words, four different spindle motors (optional equipment) can be controlled.

11.2 ALARMS, WARNINGS, INDICATOR LIGHTS, AND BUTTONS

1. Hopper sensors
 - The controller screen includes an indicator light for all installed hopper level guards. If the material in the hopper does not cover the level guard, the indicator light will be red. The level guards are located on the right-hand side of the hoppers. As optional equipment, hopper sensors can also be installed on the left-hand side of the hoppers.
2. Gearbox alarm
 - The gearbox icon shown on the main screen on a red background indicates a gearbox alarm. In this case, check the speed sensors for the machine and seed shafts first. If they are in okay, use the calibration lever to check whether the seed shaft rotates evenly. If the seed shaft rotates unevenly, open the gearbox and inspect any fault.
3. Pole lift
 - When the pole lift function is activated, a lock icon is shown in the middle of the main screen on a red background, after which the track marker can be lifted, while the coulters remain against the ground, and seeding can be continued normally.
4. Pause
 - When the pause button is pressed, a yellow pause indicator light will be shown in the middle of the screen. When the pause function is active, the lifting/lowering sensor is disabled and additional lifts are not counted.
5. Half lift
 - When the half lift function is active, i.e., the half lift button is green, the coulters and the friction wheel will be lifted slightly off the ground when the machine is lifted, while the following harrow will stay down. The half lift height can be adjusted by changing the lifting/lowering sensor's height.

11.3 FUNCTIONS ON THE SCREEN

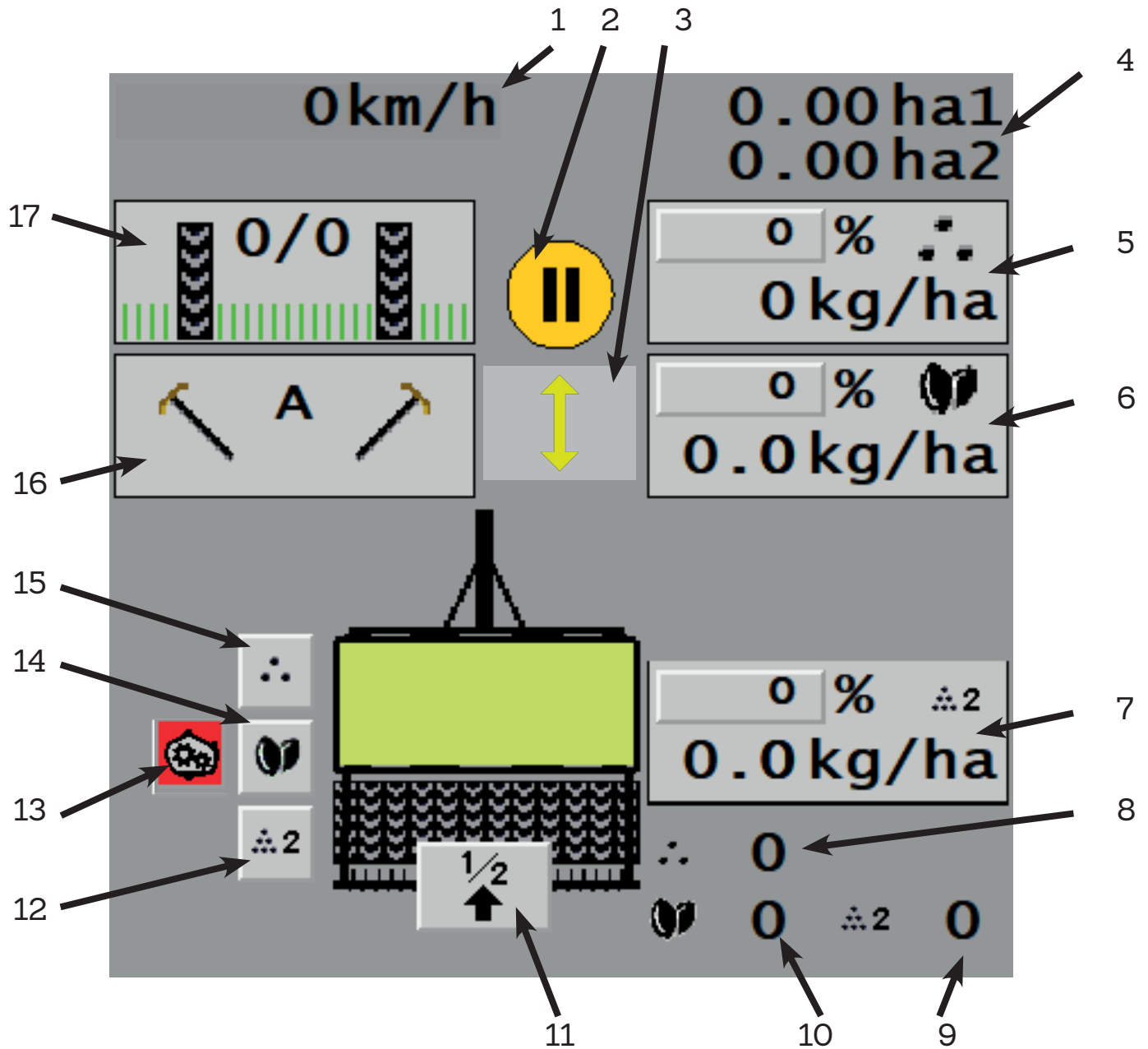

- | | |
|--|--|
| 1. Driving speed | 9. Small seed shaft rotating speed |
| 2. Pause activated | 10. Seed shaft rotating speed |
| 3. Pole lift activation | 11. Half lift activation |
| 4. Surface area counters | 12. Small seed device hopper sensor / activation |
| 5. Fertiliser remote adjustment | 13. Gearbox alarm. Red when an alarm is active |
| 6. Seed remote adjustment | 14. Seed device hopper sensor / activation |
| 7. Small seed device remote adjustment | 15. Fertiliser device hopper sensor / activation |
| 8. Fertiliser shaft rotating speed | 16. Track markers |
| | 17. Tramline clutches |

11.4 FRONT PAGE BUTTONS

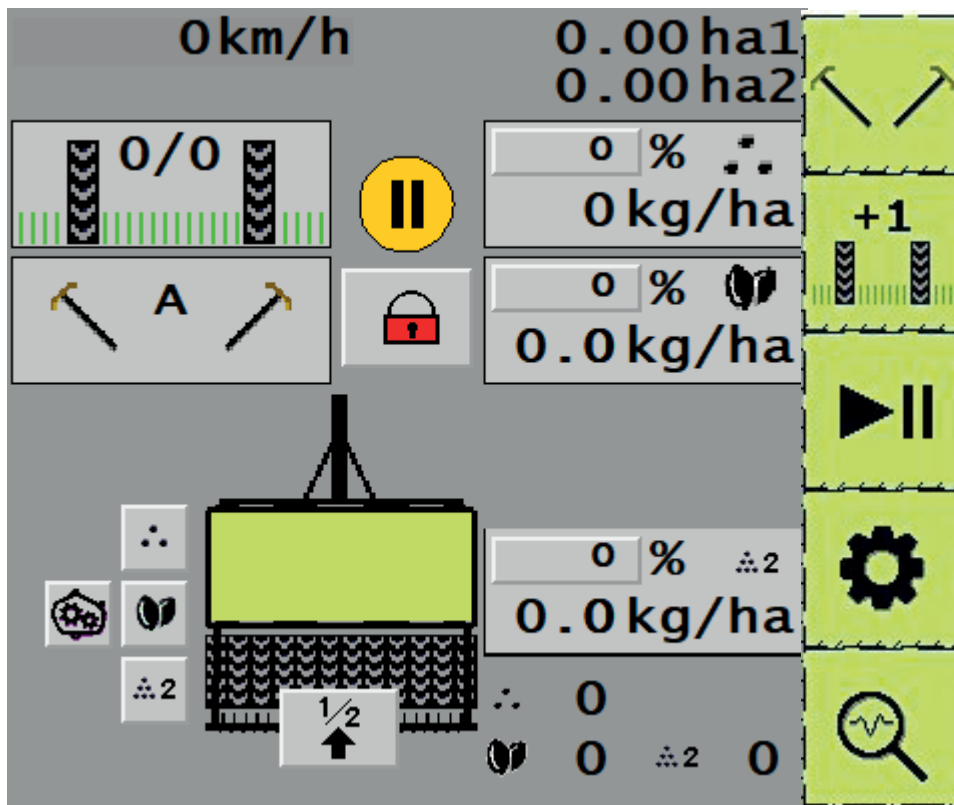

Track marker menu 11.4.1









Tramline rhythm selection 11.4.2

Pause on/off 11.4.3

Settings 11.4.4

Diagnostics 11.4.5

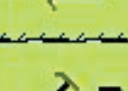
11.4.1 TRACK MARKER MENU

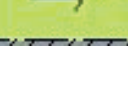
Back to main menu	
Disable track markers	 
Automated track marker function	 
Left track marker Manual function	 
Right track marker Manual function	 

When activating the automated function, first select A and then the starting side. Left or right.

11.4.2 TRAMLINE RHYTHM SELECTION

Note that the 11.4.2 icon is only displayed if the tramline clutches are installed in the machine.



The +1 button increases the counter figure by one. Note: When two identical figures are shown, e.g., 3/3, symmetrical tramlines are being produced.

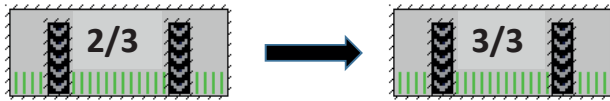

11.4.3 PAUSE ON/OFF

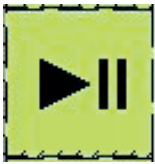

When the pause button is pressed, i.e., the coulters lifting/lowering sensor is disabled, the yellow pause icon is shown on the main screen. When the pause button is pressed again, no pause icon is shown and the lifting/lowering sensor is activated.



11.4.4 SETTINGS

SETTINGS PAGE 1



Back to main menu

Rotation test menu 11.4.4.1

Tramline settings 11.4.4.2

Surface area counter reset 11.4.4.3

Factory settings

Change settings page

SETTINGS PAGE 2



All hopper sensors on/off

Task control on/off. On in precision farming, off in normal seeding.

Alarm menu 11.4.4.4

Pole lift timer 11.4.4.5

Change settings page

11.4.4.1 KIERTOKOEVALIKKO

Note that the icons below and menu 11.4.4.1 are only displayed if the fertiliser and/or seed remote adjustment is installed in the machine.

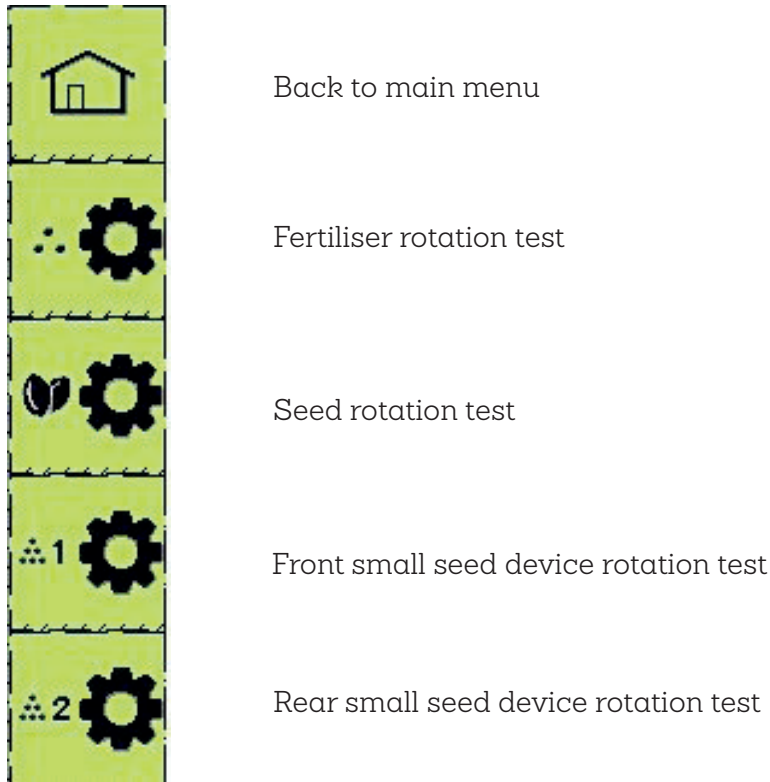

An example of the fertiliser rotation test is given below. Seed and small seed rotation tests consist of identical stages.

1. Enter the targeted volume (kg/ha)

The cylinder movement is shown on this scale.

3. The start test button moves the cylinder to the position in which the rotation test is carried out

2. Enter the desired value 1–99%

Restore factory settings

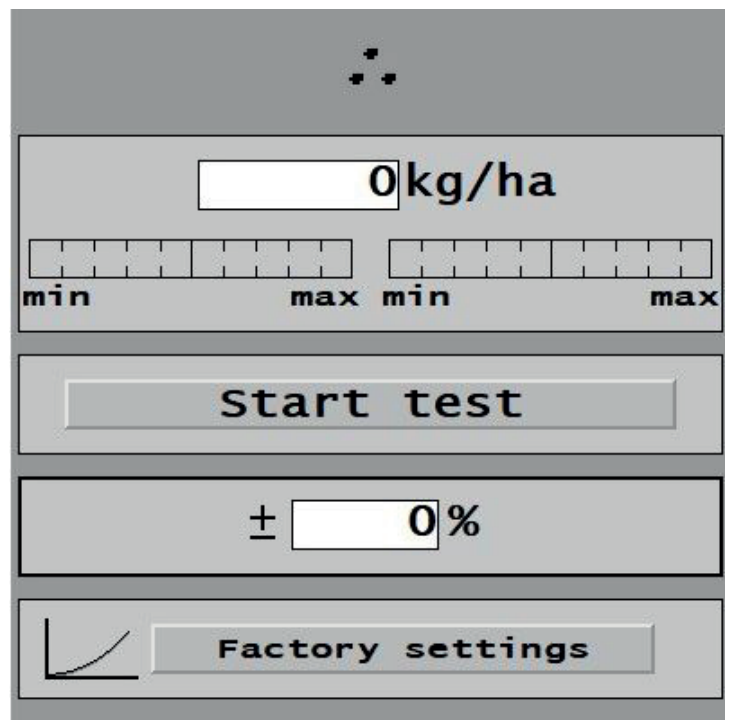

When the start test button is pressed, the menu

shown below will open in which the rotation test results are given. During the rotation test, gearboxes on the fertiliser side at the right end of the machine are rotated as many times as is shown in the rotation test sticker, corresponding to 100 m². Save the results by pressing the green V button.

4. Enter the rotation test results here

5. Save the results by pressing the green V button

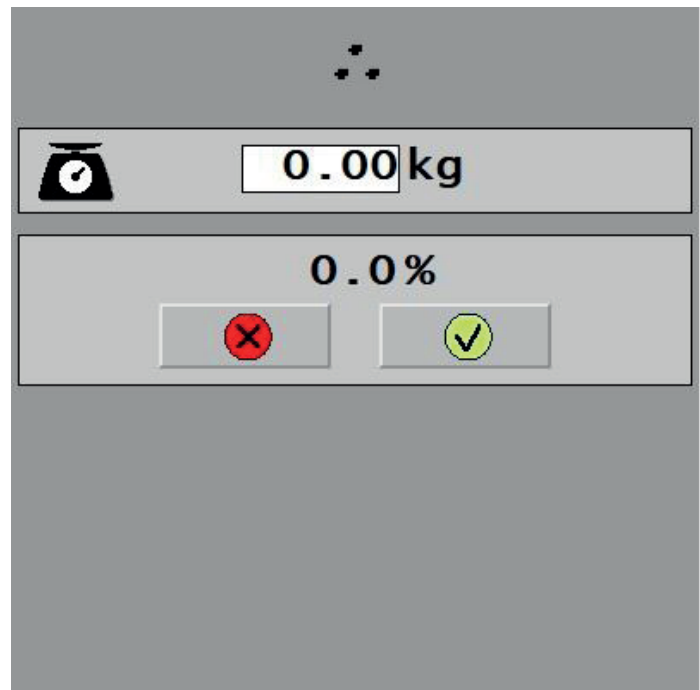

Once you have saved the rotation test results, the adjustment cylinder will make any corrections. The correction needed is shown as a percentage. After this, carry out one or two rotation tests to ensure that the results correspond to the desired kg/ha volume. When the percentage in the top menu is between 0% and 4%, the cylinder positioning accuracy has been reached and you can start seeding.

11.4.4.2 TRAMLINE SETTINGS

Note that the icons below and menu 11.4.4.2 are only displayed if the fertiliser and/or seed remote adjustment is installed in the machine.

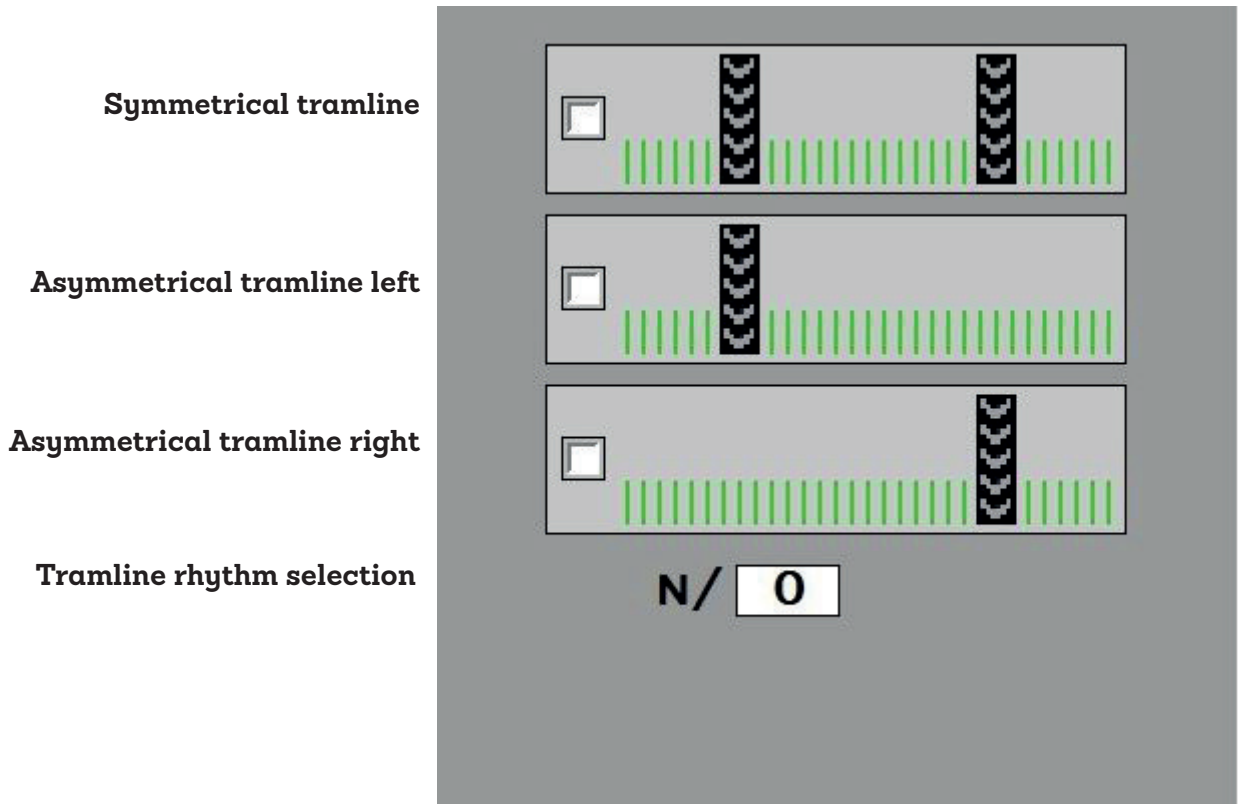

11.4.4.3 SURFACE AREA COUNTER RESET

By pressing surface area counter reset button 11.4.4.3, you can access a menu in which you can reset the ha1 and ha2 surface area counters.

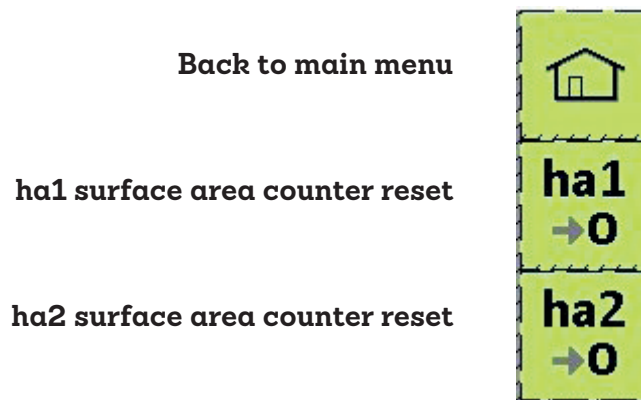

11.4.4.4 ALARMS 11.4.4.4

In the alarms menu, you can switch each alarm on or off. The list of level guard alarms only displays alarms for which sensors have been installed.

Seed hopper level guard
 Fertiliser hopper level guard
 Front small seed hopper level guard
 Rear small seed hopper level guard
 Coulters down, no speed pulses, alarm
 Gearbox alarm

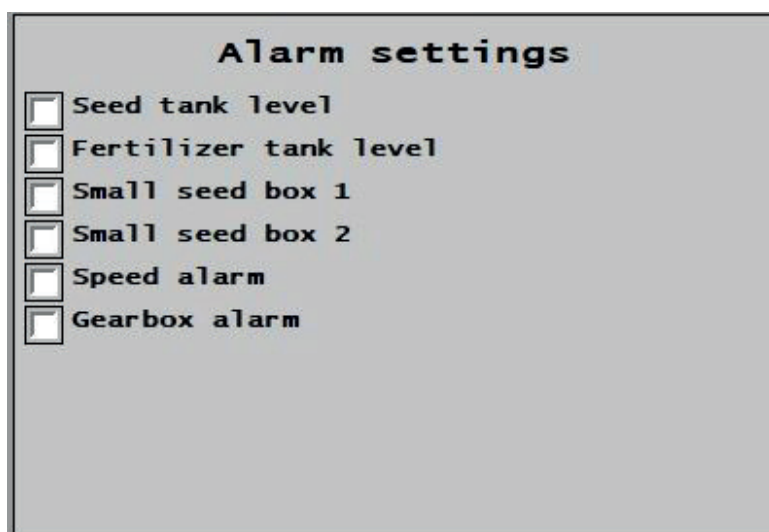

The “coulters down, no speed pulses” alarm is activated in ten seconds when the machine is down in the seeding position but no speed pulses are received. For example, if the friction wheel has been left in the transportation position or the friction wheel chain breaks.

The gearbox alarm is activated when the ratio between the rotating speeds of the cardan shaft and the seed shaft changes unexpectedly. For example, when the spring or eccentric in the seed hopper gearbox breaks.

11.4.4.5 POLE LIFT TIMER

If the pole lift timer is activated, it will automatically be disabled after the pre-defined time. This prevents any errors if the pole lift is accidentally activated when reaching a boundary strip.

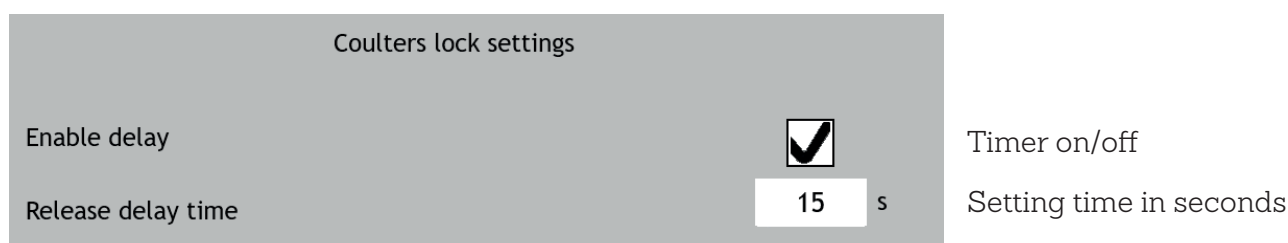

When the **Enable delay** row is ticked, the timer is on. On the **Release delay** time row, select how long the pole lift remains active.

11.4.5 HOPPER SENSORS ON THE MAIN

Any hopper sensor can be disabled by touching the grey icon, after which it will turn yellow. This can be used in situations when small seeds are fed from the seed hopper, for example.

When the button colour is grey, no alarms



When the button colour is red, alarms active



When the button colour is yellow, alarms disabled



11.4.6 HALF LIFT ON THE MAIN SCREEN

When the half lift button is green, the half lift function is active.

OFF

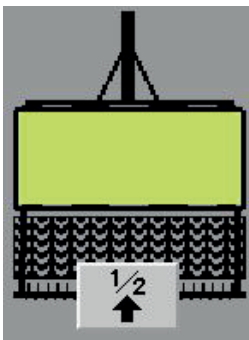

ON

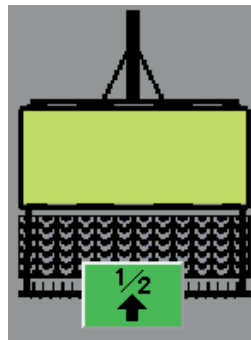

When the half lift function is active, the coulters and the friction wheel will be lifted slightly off the ground when the machine is lifted, while the following harrow will stay down. The half lift height can be adjusted by changing the lifting/lowering the sensor's height.

11.4.7 GEARBOX ALARM ON THE MAIN SCREEN

The gearbox icon shown on the main screen on a red background indicates a gearbox alarm. In this case, check the speed sensors for the machine and seed shafts first. If they are okay, use the calibration lever to check whether the seed shaft rotates evenly. If the seed shaft rotates unevenly, open the gearbox and inspect any fault.



11.4.8 POLE LIFT ACTIVATION ON THE MAIN SCREEN

When the pole lift function is activated, a lock icon is shown in the middle of the main screen on a red background, after which the track marker can be lifted, while the coulters remain against the ground, and seeding can be continued normally. The use of the pole lift timer is presented in Section 11.4.4.5.

Pole lift activation button

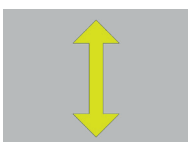

Pole lift active



11.4.9 FERTILISER REMOTE ADJUSTMENT ON THE MAIN SCREEN

When you press the button shown by the arrow on the main screen, the adjustment menu will open on the right-hand side of the screen.

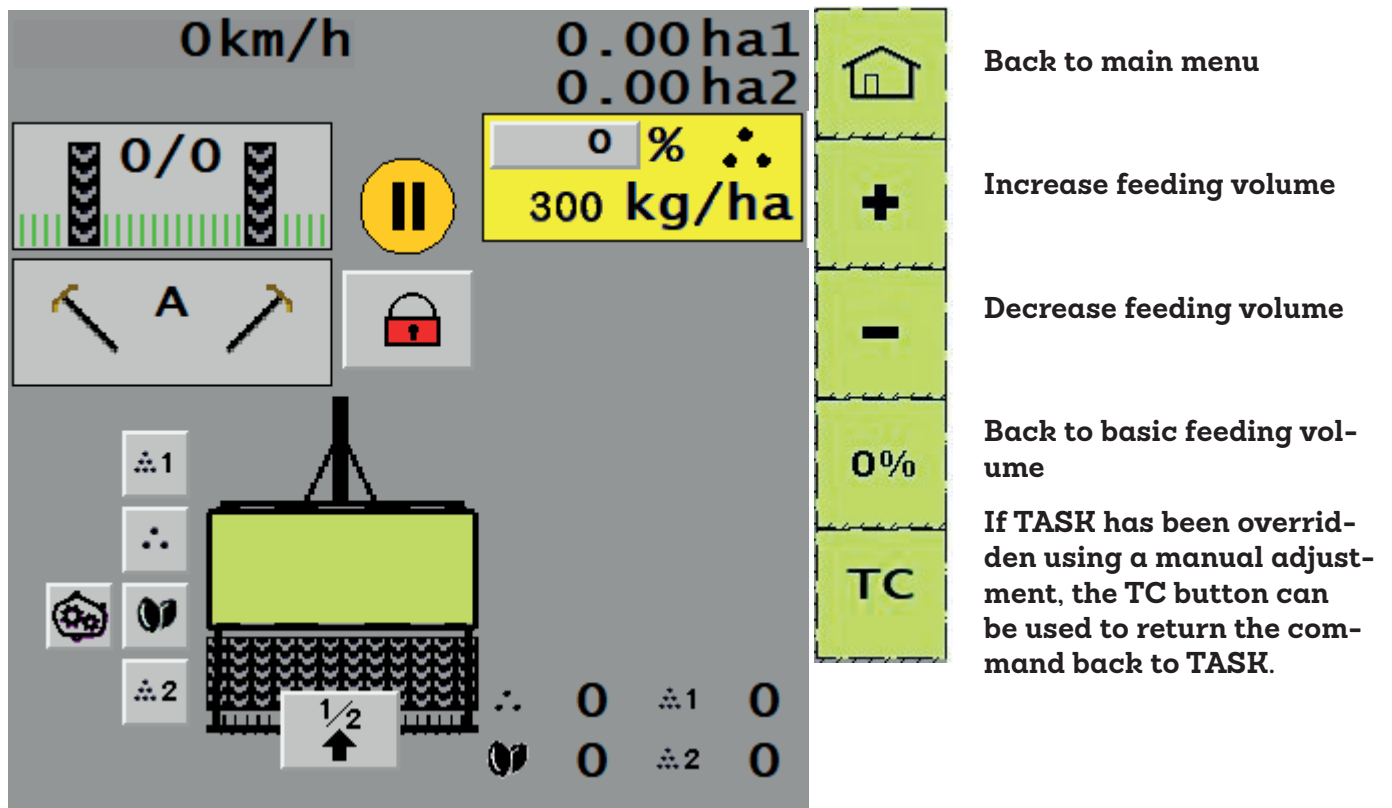

When the feeding volume is changed in the adjustment menu, the new feeding volume and the change in percentage are shown in the fertiliser remote adjustment icon. The adjustment value can be entered and changed in the rotation test menu 11.4.4.1.

If the seed and/or small seed remote adjustment is also installed in the machine, their icons are shown below the fertiliser icon on the main screen. They operate similarly to the fertiliser remote adjustment. Only one adjustment at a time can be active.

12 SEEDING

Using a new seed drill, seeding should first be tested without any seeds or fertilisers. This is important because it allows you to test the machine and control unit, and to learn machine adjustments well before the busy seeding season.

12.1 START OF SEEDING



Make sure that moving machine parts do not cause injuries to people or damage to property close to the machine.

Check before sowing:

- Bolts tensions
- Clearances of the joints and cylinder brackets
- Hydraulic hoses and hydraulic connections
- Condition of coulter wear parts and change wear parts if needed.

Check regularly during sowing:

- The condition of seed and fertilizer hoses. Make sure there is no wear or tear on the hoses. Also check that the beveled end of the hoses does not rise above the overhead guard at the coulter steel pipe.
- The condition of the coulter pressure springs and change worn springs if needed.

When driving to the field:

6. Release trackmarkers. Locking pins are located on the marker arms.
7. Lower the friction wheel and make sure that seeds and fertilisers come out from all coulters.
8. Open the valves of lifting hydraulic hoses.
9. Remove any transportation support.
10. Turn the rim removers of any disc cultivator to the working position.
11. Start the control unit.
12. Drive the first round anticlockwise so that the friction wheel is not on the edge side. This ensures that the friction wheel does not hit any obstacles or grooves that could damage the machine or stop feeding.
13. Verify the seeding depth after the first round.

12.2 SOIL PREPARATION

The correct seeding period and soil cultivation are important considering the success of seeding. The optimal seed position is between the cultivated and uncultivated layers. Direct seeding reduces the number of cultivation stages.

Conditions

- **Dry conditions:** In dry conditions, avoid cultivation deeper than at the seeding depth, in which case moisture rises to seeds from the uncultivated layer through capillary action. In clay and other dry soil, levelling the topsoil before soil preparation is a good way to maintain moisture by interrupting capillary action.

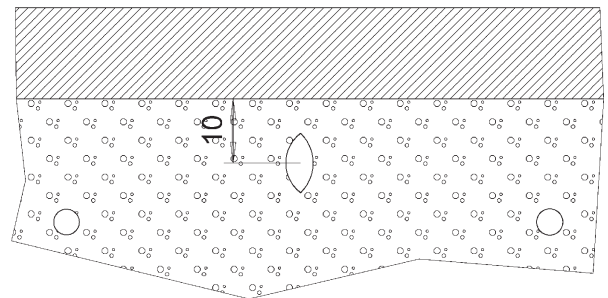

Picture 13. Optimal cultivation depth (10mm)

- **Moist conditions:** When preparing for moist conditions, the land may need to be cultivated deeper to increase the water space. It is especially important for the growth capacity and structure of soil that it is not trampled or cultivated when wet, and that machine surface pressures are as low as possible.

Direct seeding

Direct seeding also effectively retains water in the soil. Similarly, studies have shown that, the less cultivation is needed, the better plants are able to utilise nutrients in the soil. Furthermore, fewer nutrients will flow away from the field. However, if the amount of cultivation is reduced, the risk of plant diseases and weeds increases.

12.3 FERTILISATION

FERTILISER METHODS

- **Fertiliser placement** Fertilisers are placed in the seeding row, a separate fertiliser row or both. When fertilisers are placed in a row, the high nutrient concentration in the row is mainly utilisable by plants. In fertiliser placement, nutrients are placed close to seeds or under them between seeding rows.
- **Surface fertilising** Nutrients contained by spread fertiliser grains are largely absorbed in the soil, meaning that plants are unable to utilise them as effectively. In surface fertilising, the convection of nutrients to plants is largely placed on the rainwater migration effect.
- **Distributed fertilising** to spring plants is justifiable on the basis of an increased protein level or distributed risks associated with fertiliser costs. Distributed fertilising may not produce larger crops in spring seeding but a later seeding may become unnecessary if investments in the crops are unproductive due to a poor growing season. It is recommended that, during spring seeding, at least two-thirds of all of the growing season's nutrients are applied.

Fertiliser placed in the seed row

Whether fertilisers should be placed in the seed row or a separate row depends on the nutrient application method, plants, soil type and humus content. Especially if the source of nutrients is manure or other organic fertilisers, applying fertilisers into the seed row is an excellent fertilisation method. If urea is used as a fertiliser, it must be placed in a separate row.

Fertiliser storage

Store fertilisers and the seed drill protected against moisture. The best storage location for the seed drill is a machine shed with a dry base and doors. If the machine is stored on a moist base or in a place accessible by night dew, the fertiliser may form into clumps above the metering device or adhere to metering device parts. Before each seeding day, rotate some fertiliser into calibration trays, and make sure that no fertiliser has adhered to the feed roll and that the calibration trays have equal piles of fertiliser. If required, clean the rolls through the metering device cover.

12.4 SEEDS AND SEED FEEDING

Before seeding

- Only use pure seeds because any impurities may damage machine operations.
- The user is responsible for ensuring that any dressing, etc. used does not have a negative impact or prevent the metering device or coulters from operating.
- When using large seeds (larger than peas), make sure that they will not cause blockage in the machine.
- The most important is to verify a correct and even seeding depth and correct seeding volumes. Check the seeding depth in harder and softer areas, and in and next to tractor tyre tracks. A tool intended to measure the seeding depth is delivered with the machine. The seeding depth must be selected according to the plant, soil type, seeding period and moisture conditions. If seeding

conditions so require, adjust the hydraulic coulter pressure while driving.

- When monitoring the feed volume, check the feeding operation, for example, before each filling. Stop in the boundary strip, rotate the friction wheel and make sure that seeds and fertilisers come out from all coulters. Pay attention to the tramline rhythm. Before filling the machine, check visually that fertilisers and seeds are consumed evenly. However, note that the distribution of metering devices in the hopper differs slightly, meaning that the level of fertilisers and seeds in the hopper is not identical.
- Note that the seed drill must always move forward when it is being lowered to the ground or raised off the ground. Do not stop if the machine is lowered to the ground. If you need to stop during seeding, lift the machine while driving. Before continuing, reverse a few metres and lower the machine while driving. Otherwise, coulters may be clogged, particularly in moist conditions. When reversing, make sure that the coulters do not touch the ground. They may be clogged or damaged. Always lift the machine all the way up before reversing.

 Junkkari seed drills and metering devices are designed to operate accurately and reliably. Junkkari Oy cannot be held liable for damage caused by incorrect adjustments or working methods.

Junkkari Oy is not responsible for any seeding-related indirect damage.



If a coulter is clogged, do not go under the machine without using sufficient mechanical supports.

12.5 ECONOMICAL SEEDING

Seeding is a key factor in productive cropping. This section offers a summary of simple actions that affect the input-output ratio of seeding. The aim is to save time and money, and improve production.

INSTRUCTIONS FOR ECONOMICAL SEEDING

Tractor

- Adjust the tractor's tyre pressures correctly and use collaring which minimises tyre slippage. Tyre slippage directly increases fuel consumption. Reducing slippage by 5% refers to an improvement of 5% in fuel economy.
- Use a tractor of a correct size. An excessively large tractor tramples the field and consumes more fuel.
- Utilise your tractor's economical torque range and transmission. Driving at unnecessarily high revolutions increases fuel consumption significantly.

Seed drill

- Use large tyres in the seed drill. The tractive resistance of the seed drill plays an important part in terms of fuel economy. In cultivated soil and soil rich in humus, large tyres produce the most benefits.
- Particularly, soil rich in humus and heavy soil with a high tractive resistance are suitable for fertilising the seed row. Without fertiliser coulters, the tractive resistance and fuel consumption are lower.
- Use economical driving lines. Try to seed while lifting the machine as infrequently as possible. Generally, seeding is not the most economical way to seed because turning takes a lot of time and the final rounds are short.
- Minimise any unproductive time on roads and organise the use of the seed drill to be as effective as possible.
- Maintain the seed drill in advance. Clean, lubricate and protect the machine properly between seasons. This will retain the resale value and reduce any operating breaks during seasons.

Soil preparation

- Avoid any unnecessary rounds. Perform any basic cultivation so that the result is as even as possible. This reduces the amount of cultivation needed. Also utilise the cultivating effect of the seeding combination. In larger areas, you can achieve savings if you use a guidance system or automatic steering to avoid overlapping rounds.
- Do not cultivate too deep. Cultivation consumes fuel and moisture will evaporate and not be available to seeds if the cultivation depth is higher than the seeding depth. If so permitted by conditions and coulters, the cultivation depth should be one centimetre lower than the seeding depth.

Sowing

- Direct seeding produces savings in a number of work stages. At the same time, the field's carrying capacity is better on uncultivated soil, which also saves fuel.
- Remove any obstacles from the field. For example, driving around rocks or other obstacles takes a surprising amount of time during a year. By removing any obstacles, you can also reduce the risk of machine damage.
- Use tramlines. They reduce the amount of green plants in rows. Spraying is also quicker and easier, and there will be fewer overlapping rounds.
- Adjust the seeding depth correctly. In particular, even sprouting on clay and silt soil requires precision.
- Always calculate the seed volume required on the basis of the seed weight and germinative capacity. Adjust the seed drill according to calibrations.
- Take care of the soil's growing capacity (structure, pH, nutrients, moisture).
- Maintain circulating seeding practices.
- If possible, use organic fertilisers to achieve savings in fertiliser costs and increase the volume of humus.
- Only use productive input when necessary. For example, precision fertilising serves to apply fertilisers in varying conditions as required.
- Take care of the driver's occupational safety, sufficient rest and nutrition.

13 OTHER OPTIONAL EQUIPMENT

13.1 PACKER

The packer packs and levels the soil between tractor tyres before coulters. Depending on the machine type, a wide or narrow packer can be used.

Remember:

- Align the packer on the tractor's centre line using the tractor's side limiters.
- During seeding and in boundary strips, the packer is lowered down.
- Do not load the packer using any additional hydraulic pressurisation.
- The packer must always be raised up when driving on public roads and before reversing.
- Check the pressure of packer tyres while checking the pressure of rear wheels.
- Lubricate any moving parts according to lubrication instructions.

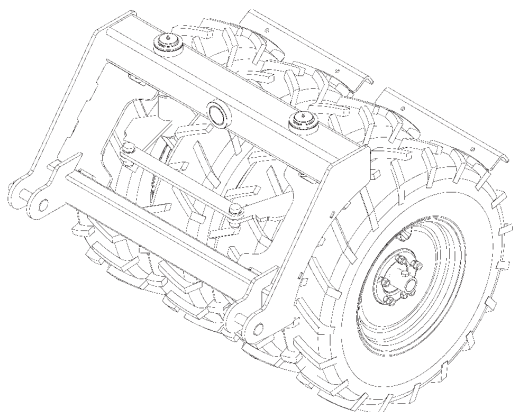

Picture 15. 7.5"X16" tyre

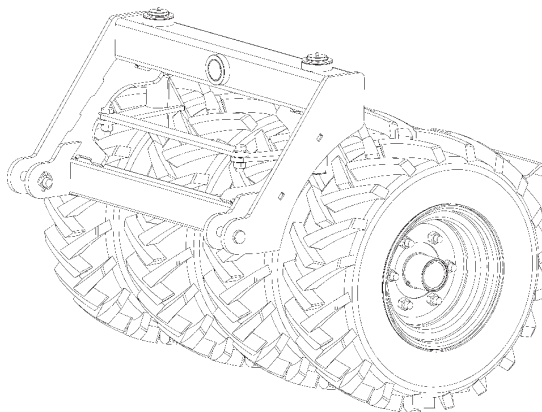

Picture 16. 10"X15.3 tyre

13.2 SMALL SEED AND STARTER FERTILISER DEVICE

Junkkari S-, M- and D-series seed drills can be equipped with a small seed and starter fertiliser device. It can be used to apply small seeds, such as rapeseeds, hay or mustard seeds. When applying small seeds, the small seed roll of the metering device is used. The location of the material applied can be selected to be in the seed coulter or surface using the seed drill's switch valve.

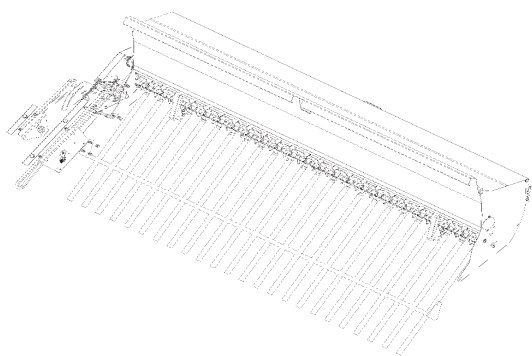

Picture 17. Small seed device

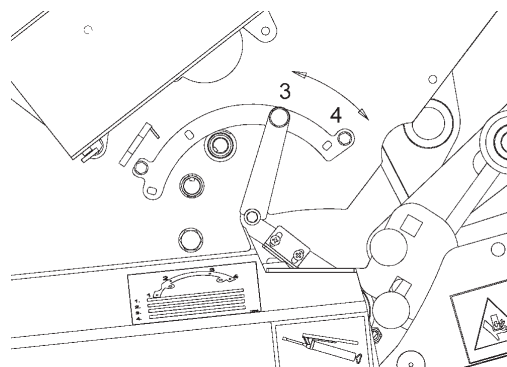

Picture 18. Switch valve

The device consists of a seed hopper, feeding mechanism and gearbox with transmission. It is used and adjusted similarly to the seed drill's seed side. The only exception is that the calibration is performed downwards into the calibration tray through the actual seed metering device.

When the device is used to dose starter fertiliser, deactivate the mixer shaft by moving the locking pin at the end of the shaft to the outermost hole. (Picture 86.)

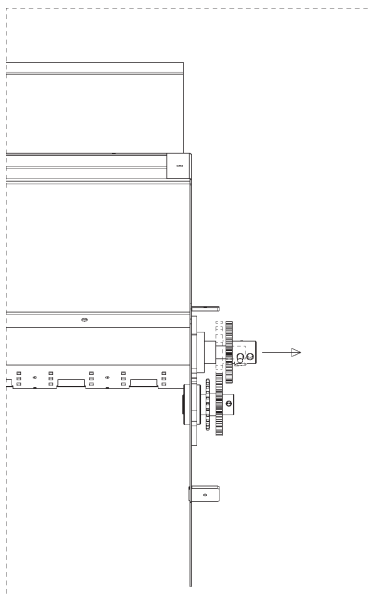

Picture 19. Deactivating the mixer shaft

13.3 FRONT LEVELLER

The front leveller levels the soil and crushes crumbs before coulters. The leveller is controlled using the tractor's double-acting hydraulics. Depending on the machine type, a 1-row or 2-row leveller can be used.

Remember:

- Always before reversing, make sure that the leveller does not touch the ground.
- Tighten the screw connections of the leveller after a few operating hours.

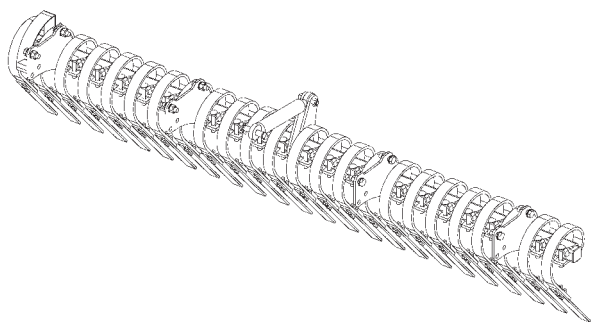

Picture 20. 1-row front leveller

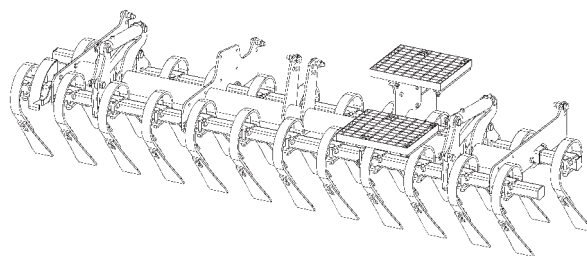

Picture 21. 2-row front leveller

13.4 S-TINE

The S-tine is used to cultivate and loosen the soil. In dry conditions, the S-tine can break the evaporating capillary action. In easily crumbling soil types, the S-tine can cultivate the soil directly during seeding. The best cultivation result can be achieved when the tractor uses dual tyres according to the seed drill's width and the seed drill is equipped with a packer so that the entire working width is evenly packed before the S-tine. The working depth and aggression of the S-tine can be adjusted using the tractor's double-acting hydraulics.

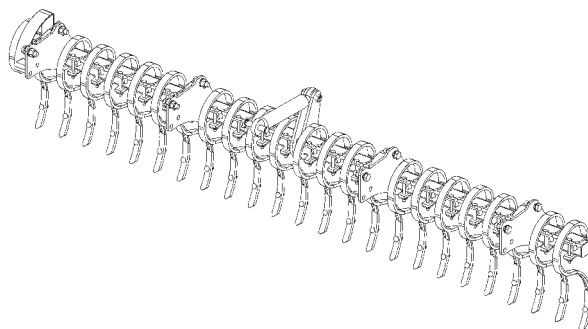

Picture 22. S-tine

13.5 DISC CULTIVATOR

Using a disc cultivator, the number of cultivation times can be reduced and, in specific conditions, seeding is possible directly in a stubbly field. The working depth of the disc cultivator can be adjusted using the tractor's double-acting hydraulics.

Remember:

- The use of the disc cultivator should be avoided in highly moist soil because, if cultivated, moist soil becomes too packed when trampled using a seed drill.
- Avoid cultivation at too high a depth because moisture may not reach seeds and fuel consumption increases unnecessarily.
- Make sure that the cultivator is horizontal when the machine is in the seeding position. The position of the cultivator is adjusted by adjusting the height of the cultivator's front suspension.

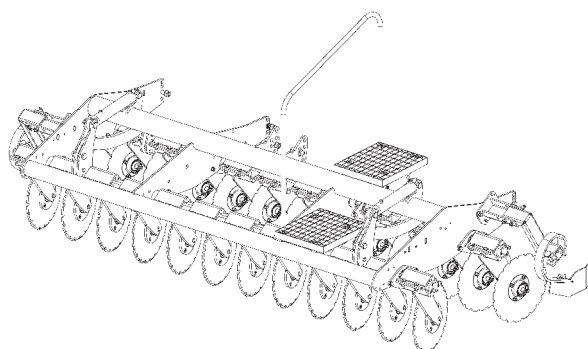

Picture 23. Disc cultivator

14 MAINTENANCE AND SERVICING



Pay attention to safety when maintaining the machine. Do not go under the machine. Lubricate the machine from the top and support it using maintenance supports. Check safety instructions at the beginning of this manual.

14.1 EMPTYING, CLEANING AND STORING THE MACHINE

To ensure machine operations without any interruptions, the machine must be cleaned, maintained and stored properly..

EMPTYING THE MACHINE

- ⓘ Empty the machine immediately after the seeding season.
 - ⓘ Do not store any seeds or fertilisers in the machine for longer periods.
 - **If there is a small volume of seeds or fertilisers in the hopper, they can be emptied into calibration trays.:**
1. Install calibration trays into place.
 2. Turn the switch valves to the emptying position (position 1).
 3. Open the bottom valves in full.
 - Larger volumes can be emptied on a clean floor or tarpaulin through coulters when the switch valve is in position 3 or 4. .
 - Any poorly flowing material can be assisted by turning the calibration lever.
 - The best way to perform final emptying is to use compressed air.

CLEANING THE MACHINE

- The metering device and the interior of the feed roll should be cleaned during and after the seeding season using compressed air.
- ⓘ Cleaning is especially required if the locking pin is difficult to move or there are impurities inside the black roll.
- After cleaning, wash the machine and apply lubricant and oil after the operating season.
- ⓘ However, do not direct the spray of water to electrical equipment, bearings, the gearbox breather or seals.
 - ⓘ When using washing agents, check their suitability and follow the manufacturer's safety regulations.
 - ⓘ Only use oil designed to be used as protection which does not damage the painted surface or the environment.
 - ⓘ Do not apply any oil to plastic or rubber parts.

STORING OF THE MACHINE

- Store the machine cleaned and lubricated indoors in dry conditions protected against sunlight.
- Use the lifting cylinder's maintenance support during storage. Drive the piston arms of other cylinders as much inside as possible before storage and apply oil to any arms left outside..
- Close the hydraulics ball valve.
- Store the control unit screen in a dry and warm place.

14.2 LUBRICATION AND GREASING

Lubricate the machine at intervals presented in the table below and always after pressure washing, and after the seeding season.

Greasing area	Greasing interval	Number of nipples		
		S series	M series	D series
Lifting cylinder	100 hectares and after washing	2	2	2
Rolling wheel frame joints	100 hectares and after washing	3	3	3
Pivot bearings in rolling wheel bogies	100 hectares and after washing	4	4	4
Rolling wheel shaft bearings	100 hectares and after washing	8	8	8
Harrow arm joints	100 hectares and after washing	2	2	2
Trackmarker hinges	100 hectares and after washing	2	2	2
Trackmarker cylinders	100 hectares and after washing	4	4	4
M-coulter pressure cylinders	100 hectares and after washing	-	2	-
D-coulter fastening joint	100 hectares and after washing	-	-	18/24
D-coulter support wheel joint	100 hectares and after washing	-	-	18/24
D-coulter press wheel joint	100 hectares and after washing	-	-	18/24
Packer arm joints	100 hectares and after washing	2	2	2
Packer wheel bearings	100 hectares and after washing	2/4	4	4
Joints between the packer and draw boom	100 hectares and after washing	2	2	2
Disc cultivator cylinders	200 hectares and after washing	-	4	-
2-row leveller cylinders	200 hectares and after washing	-	4	-
2-row S-tine cylinders	200 hectares and after washing	-	4	-

Table 23. Machine greasing

Lubricating the gearbox freewheel clutch

Regularly lubricate gearbox freewheel clutches with oil.

1. Turn the calibration lever so that the halves of the freewheel clutch open.
2. Drip oil onto the halves and turn the lever a few rounds.

The lever must turn easily and the freewheel clutch must click two times during each round.

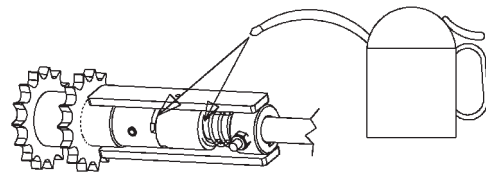

Picture 24. Lubricate freewheel clutch

Lubricating roller chains:

1. Lubricate the friction wheel arm chain, gearbox chain on the fertiliser side, transmission chain on the seed side and any small seed device chains once during each seeding season.
2. At the same time, check the chain tightness and any wear.

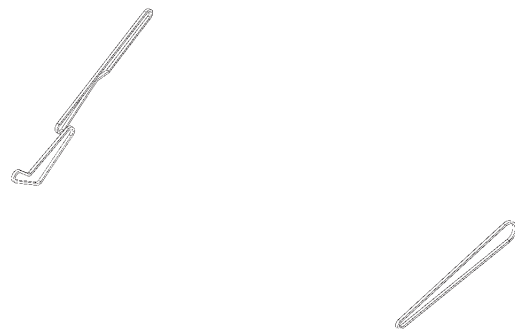

Picture 25. Lubricating roller chains

Lubricating harrow lifting joints

Picture 93

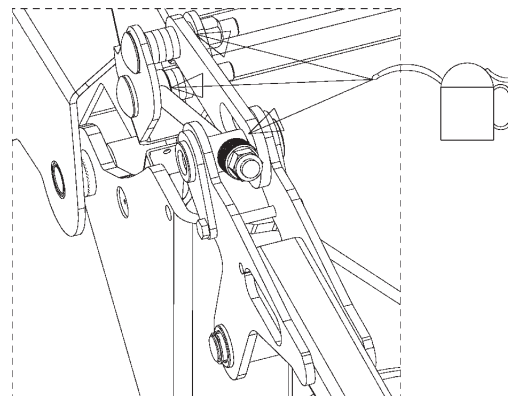

Picture 26. Lubricating harrow lifting joints

Lubricating the friction wheel shaft and cardan shaft:

Lubricate the slide surfaces of the friction wheel and cardan shaft when necessary and after the operating season. (Picture 94.)

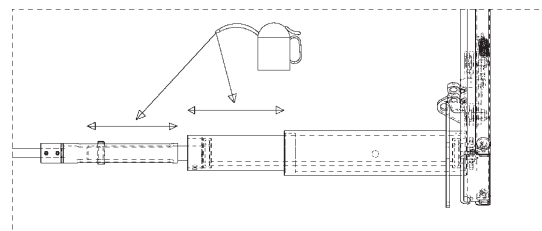

Picture 27. Lubricating the shaft

14.3 GEARBOX

- If the seed drill has remained unused for a longer period, adjust the gearbox speed at its minimum value.
- Check the gearbox oil level at least once during the seeding season. It is recommended that gearbox oils are changed at least every five years in order to remove any condensed water from the gearbox.
- Check the oil level with the machine in horizontal position. The oil level must be in the middle of the gauge.
- Also check the tightness of Stefa and other seals. The oil volume is 1.3 litres. Use a hydraulic oil of the ISO VG 32 grade. Recommended oils include. (Table 24.)

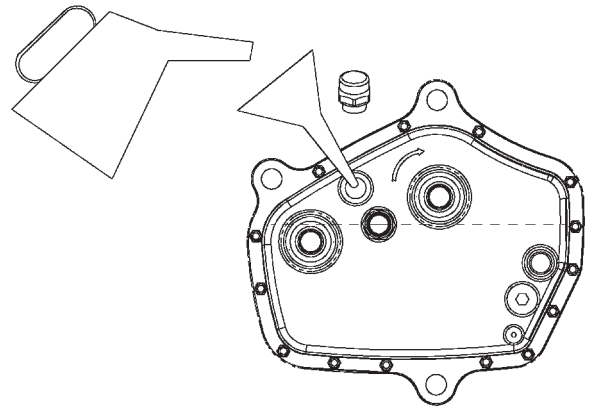

Picture 28. Lubricating gearbox

14.4 TYRES

Check tyre pressures before each seeding season and visually at least once a day during the season.

i The air pressure has a direct impact on the total surface pressure of the machine, which in turn affects the field. However, the tyre's bearing capacity decreases at a lower tyre pressure. If the tyre pressure is lower than the recommended value, reduce the transportation speed.

Neste Hydraul 32
Shell Tellus Oil 32
BP Energol HLP -D32
Statoil HydraWay Hm32
Texaco Rando Oil HD32
SuperMobil DTE 24

Table 24. Recommended oils

14.4.1 TYRE PRESSURES

The values presented in table 25 have been defined according to the machine weight and the transportation speed of 40 km/h which is the structural top speed of the tyres.

Tyre	Recommended	Max.
7.50 - 16	1,8 - 2,5 bar	2,5 bar
7.50 - 20	1,8 - 2,5 bar	2,5 bar

Table 25. Tyre pressures

14.4.2 CHANGING TYRES

Tyres are the easiest to change when the machine is empty and on a hard base. The outermost tyres can be removed directly from the machine. To change the other tyres, remove the bogie swing from the rolling wheels.

i If the seed drill is used in conditions where tyre breakage is probable, Junkkari recommends that tyres filled with polyurethane (available as optional equipment) be used.

Before tyre change:

1. Empty machine.

2. Drive the machine onto a hard and level base.

Removing a tyre:

1. Lower any packer to the ground.
 2. Lower the machine to a position where the bogie swing is horizontal.
 3. Lighten the wheel set by lifting it from the rear frame beam next to the rocker shaft. Make sure that the lifting tool is firmly underneath the beam and the machine cannot fall under any circumstances.
 4. Remove the rocker shaft's fastening flanges.
 5. Lift the machine so that rocker shafts can be removed from their slots.
 6. Pull the rocker shaft to the side using a hand pallet truck or another device.
 7. Turn the rocker shaft upside-down.
- ⚠ Make sure that the rocker shaft is not damaged when turning it.
8. Remove any rock guides from between the tyres.
 9. Remove the fastening bolts of the shaft's flange bearing and remove the wheel set from the rocker shaft.
 10. The tyres can be pulled off the shaft over the fastening flanges and flange bearings.
 11. Assemble the wheel set in reverse order.

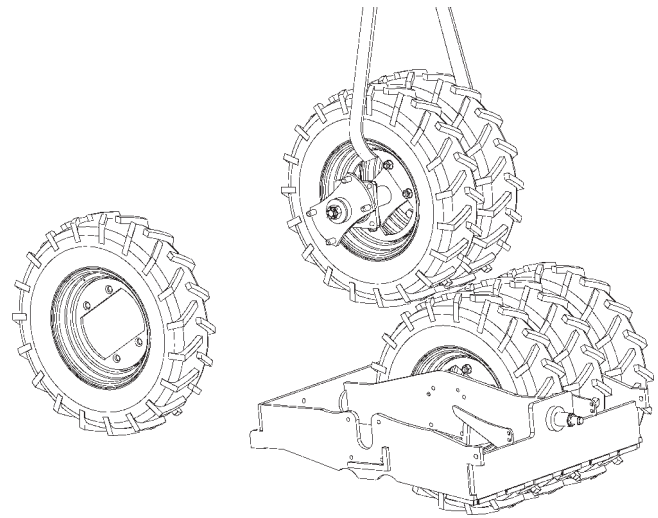

Picture 29. Removing a tyre

14.5 REPLACING WEARING COULTER PARTS

⚠ **Make sure that the machine is properly supported and cannot fall down under any circumstances.**

14.5.1 REPLACING S-SERIES WEARING COULTER PARTS

REPLACING THE S-SERIES COULTER DISC

1. Remove the couler side plate.
2. Remove the disc bearing cup by removing the Seger wheel.
3. Remove the locking nut of the disc shaft bolt from the couler arm.
4. Remove the disc by loosening the shaft bolt.

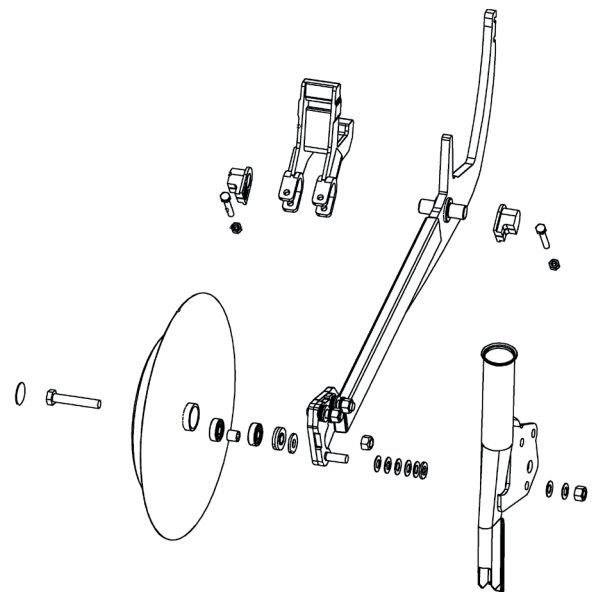

Picture 30. S-series couler parts

5. Extract the disc fastening sleeve from inside the bearing.
6. Install the Stefa seal in a new disc.
7. Push and lock a new bearing into the couler disc using the lock ring.
8. Push the disc fastening sleeve inside the bearing of the new disc.
9. Attach the disc to the couler arm using the shaft bolt.
10. Fill the bearing housing using Vaseline.
11. Tighten the locking nut of the shaft bolt to the couler arm.
12. Install the cup back into place and lock it using the lock ring.

REPLACING THE S-SERIES COULTER SIDE PLATE

When installing a new side plate, the gap between the couler disc and side plate must be adjusted so that the side plate touches the disc in its lower corner. There must be a very small gap between the disc and side plate backwards and upwards.

1. The contact point can be adjusted using the M10 fastening nuts.

i For example, the lower side plate corner tightens against the disc by tightening the bottom-most nut.

2. Finally, check that the couler disc rotates freely.

! If the side plate is adjusted incorrectly, plant waste may accumulate in the gap.

REPLACING THE PLASTIC BEARING IN THE S-SERIES COULTER ARM

1. Open the spring fastening from the couler.
2. Remove M10 bolts that lock the plastic bearing to the couler fastener. Then, the couler arm can be turned out of the fastener.
3. Remove any worn plastic bearings and install new ones.
4. Lift the couler arm into the slot in the fastener and attach M10 screws.

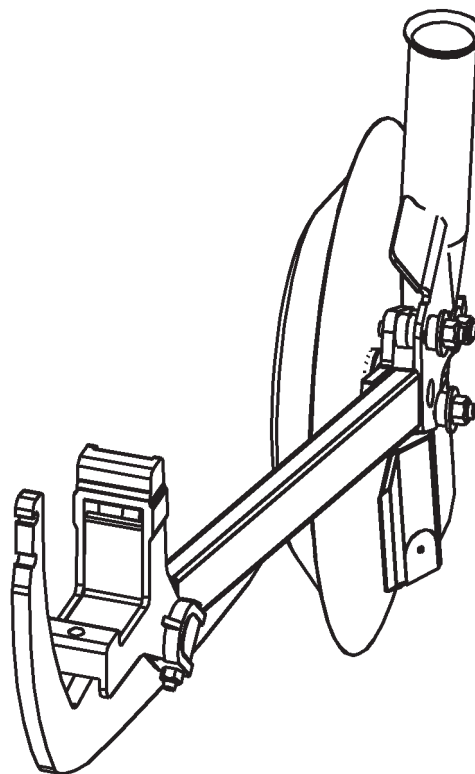

Picture 31. Replacing the S-series couler disc plate

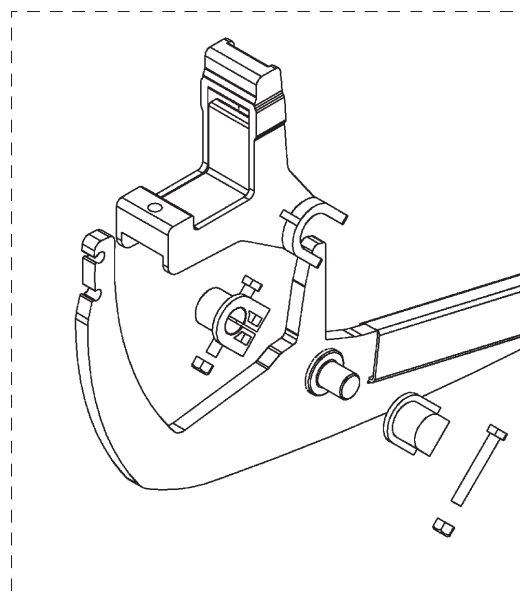

Picture 32. Replacing the plastic bearing in the S-series couler arm

5. The screws must be tightened so that there is no free play and the coultter arm can drop freely from its upper position.

i The free play can be adjusted slightly by tightening the screws of the coultter fastener.

14.5.2 REPLACING M-SERIES WEARING COULTTER PARTS

REPLACING THE M-SERIES COULTTER DISC

1. Remove the coultter from the machine frame by opening the two M10 bolts in its fastener joint.
2. Remove the disc bearing cup by removing the lock ring.
3. Remove the lock ring from underneath the cup.
4. Pull the coultter disc out of the shaft.
5. Install the seal in a new disc.
6. Push and lock a new bearing into the coultter disc using the lock ring.
7. Push the coultter disc onto the coultter shaft and fill the bearing housing with Vaseline.
8. Install the lock ring which holds the bearing onto the shaft.
9. Install the cup back into place and lock it using the lock ring.

REPLACING THE M-SERIES COULTTER SIDE PLATE

When installing a new side plate, the gap between the coultter disc and side plate must be adjusted so that the side plate touches the disc in its lower corner. There must be a very small gap between the disc and side plate backwards and upwards.

1. The contact point can be adjusted using the M10 fastening nuts.

i For example, the lower side plate corner tightens against the disc by tightening the bottom-most nut.

2. Finally, check that the coultter disc rotates freely.

! If the side plate is adjusted incorrectly, plant waste may accumulate in the gap.

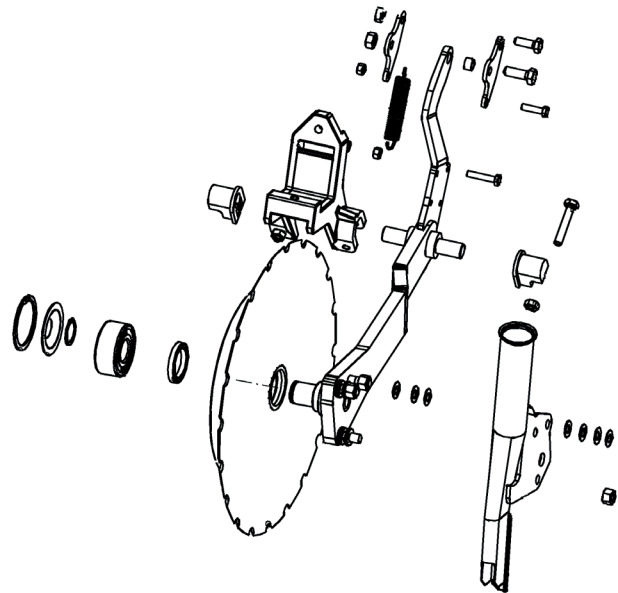

Picture 33. Replacing M-series wearin coultter parts

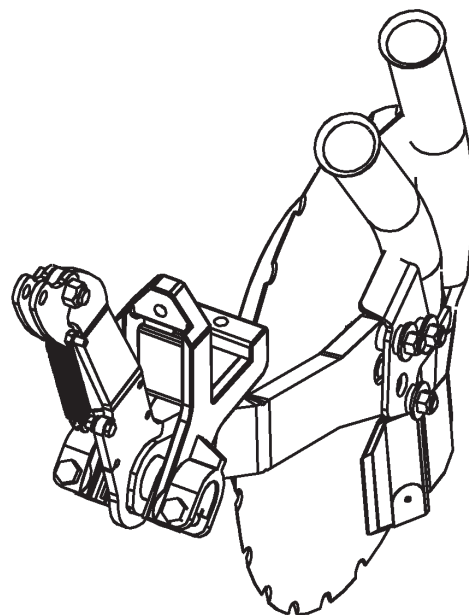

Picture 34. Replacing the M-series coultter disc plate

REPLACING THE PLASTIC BEARING IN THE M-SERIES COULTER ARM

1. Open the spring fastening from the coulters.
2. Remove M10 bolts that lock the plastic bearing to the coulters fastener. Then, the coulters arm can be turned out of the fastener.
3. Remove any worn plastic bearings and install new ones.
4. Lift the coulters arm into the slot in the fastener and attach M10 screws.
5. The screws must be tightened so that there is no free play and the coulters arm can drop freely from its upper position.

i The free play can be adjusted slightly by tightening the screws of the coulters fastener.

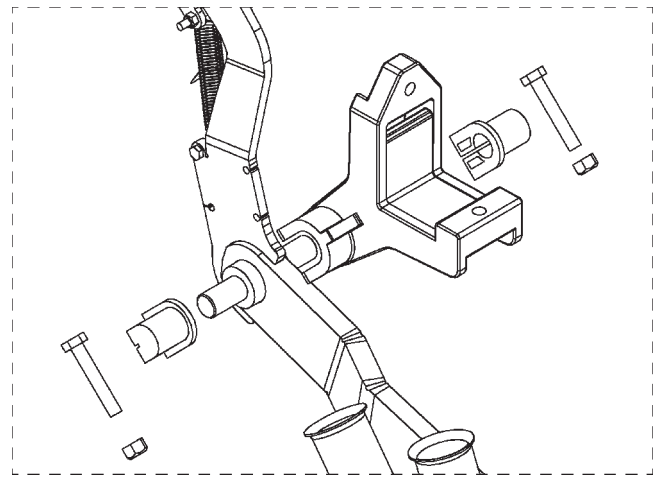

Picture 35. Replacing the plastic bearing in the M-series coulters arm

14.5.3 REPLACING WEARING D-SERIES COULTERS PARTS

The coulters disc, supporting wheel, press wheel and other wearing coulters parts can be replaced separately.

For repairing the coulters, remove it from the seed drill frame.

The coulters is attached to the machine frame beam using a pin fastened using an M12 screw.

⚠ Before starting work, make sure that the machine is properly supported and cannot cause a hazard under any circumstances. When removing the coulters, remember that it is heavy.

REPLACING THE D-SERIES COULTERS DISC

The disc is attached to the hub using six sunk screws.

1. Remove the bearing locking ring under the hub cup.
2. Remove the hub. The hub has a collar which can be used when extracting it.
3. When extracting the hub, check the condition of the shaft's seal and replace it, if necessary.

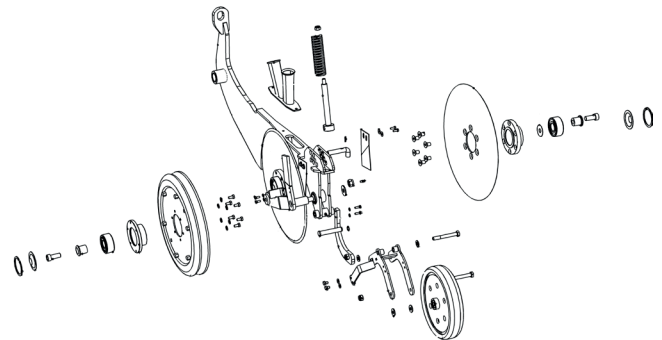

Picture 36. D-series coulters parts

REPLACING WEARING D-SERIES PARTS

- Replace **wiper discs** if they are so worn that they cannot be tightened..
- To remove the **supporting wheel**, open the crown nut and turn the arm so that it can come off its shaft. If the Drymet bearing of the supporting wheel is worn loose, replace it before steel parts start to wear.
- Regularly check the clearance of the coulter **fastening pin**. If the coulter moves sideways so that coulters hit each other, replace the Drymet bearings. .
- Finally, check that the **coulter discs** rotate freely and all moving parts move freely.

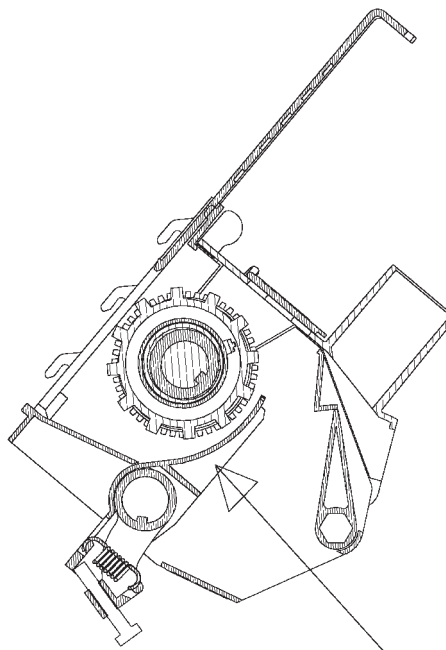

Picture 37. Replacing the metering device

14.6 REPLACING THE METERING DEVICE'S BOTTOM FLAP AND ROLL

Feeding volumes are crucially affected by the condition and proper adjustment of feed rollers and bottom flaps. The bottom flaps have been adjusted at the factory but it is possible that foreign objects, etc. have caused damage. A damaged bottom flap must be replaced.

Calibration indicates whether or not feeding is even. If a seed or fertiliser pile differs from others, check the condition of the specific bottom flap.

14.6.1 REPLACING A BOTTOM FLAP

1. If the hopper is not empty, close all closing hatches above the feeding hoppers before replacing the bottom flap.
2. Loosen the bottom flap.
3. Remove as many bottom funnels as required to grab the bottom flaps to be removed.
4. Release the bottom flap shaft by removing the fastening screw of the bottom flap's adjustment handle from the shaft.
5. Pull the shaft outwards from the end of the machine so that you can remove the damaged bottom flap.
6. Adjust the tightness of the bottom flap so that it is identical to other bottom flaps.
7. Place the bottom flap in its housing and push the shaft back into place.

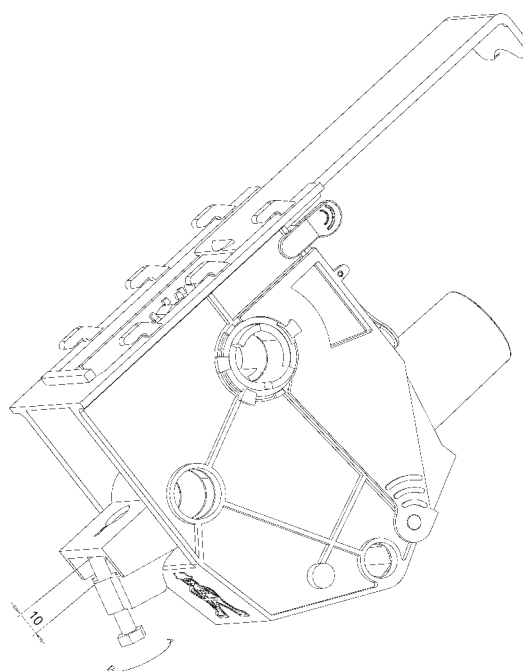

Picture 38. Adjusting a bottom flap

8. Once the bottom flap has been replaced, check its adjustment.

14.6.2 ADJUSTING A BOTTOM FLAP

In new machines, the bottom flap spring has been adjusted at the factory. The basic adjustment of the bottom flap spring must be performed when the dimension shown in the picture 106 is 10 mm. All bottom flaps must be adjusted similarly.

Turn the bottom flap adjustment switch to position 1 to check the clearance of the bottom flap and feeding rifle by feeling with your finger (0.5 mm).

14.6.3 REPLACING THE FEED ROLLER

1. Remove the feed shaft's locking screw from the right end of the machine and pull the feed shaft sufficiently out from the machine.

Note that the tramline clutch and intermediate sleeve will fall out when extracting the shaft.

2. Open the closing hatch of the feed housing.

3. Extract the roller out from the housing.

4. Put a new roller in to the housing.

5. When the rifle and plastic bearings are pushed back into the housing, make sure that the plastic bearing's bracket points towards the bottom of the groove.

6. Close the metering device's closing hatch which locks the roller into its place.

7. Push the feed shaft back into place so that the key inside the roller sits in the shaft's keyslot.

8. Make sure that the tramline clutch (if any) and the sleeve between metering devices are positioned correctly.

9. Lock the shaft into place using the screw at the right end of the machine to lock the feed shaft to the mechanism.

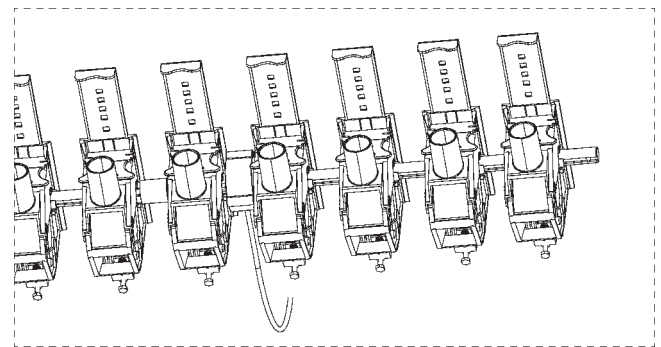

Picture 39. Replacing the feed roller

15 TROUBLESHOOTING

FAULT	CAUSE	REPAIR MEASURE
Calibration does not produce the same result as curves	Incorrect adjustment	Check the adjustment
	Incorrect direction of rotation	Check the direction of rotation
	Incorrect rotation volume	Check the rotation volume
	Incorrect bottom flap position	Check the bottom flap
	The curves are indicative	Define the seeding volume through calibration or test it by driving
The machine feeds less than required by calibration	Incorrectly performed calibration	Re-calibrate
	Bottom flap or closing hatch in incorrect position	Check the bottom flap and closing hatch
	Metering device or feed roller blocked	Remove the cause of the blockage and check the feeding volume through calibration
	Fertiliser absorbed moisture and adhered above metering device	Tap the bottom of the hopper lightly using a rubber hammer and perform calibration
	Fertiliser absorbed moisture and adhered to the feed roller	Clean the feed rollers
	Friction wheel does not rotate	Remove any foreign objects and check that the friction wheel rotates freely
	Friction wheel adjusted too high	Check the height adjustment of the friction wheel
	Gearbox adjustment lever loose	Check the tightness of the adjustment lever
	Gearbox damaged	Check the operation of the gearbox through calibration and a rotating test
	Damaged feed roller	Check the condition of feed rollers
The machine feeds more than required by calibration	Machine vibration packs seeds tighter and increases the feed volume	Specify calibration after a short period of seeding
	Incorrectly performed calibration	Re-calibrate
	Gearbox adjustment lever loose and moved	Check the tightness of the adjustment lever
	Bottom flap switch in incorrect position	Check the position of the bottom flap switch

Feed volume between feed housings varies	Bottom flaps in different positions	Adjust
	Closing hatches in different positions	Adjust
	Blockage in metering device	Remove the cause of the blockage
	Feed roller clogged	Clean the feed rollers
	Small seed settings active in some feed housings	Check the setting
	Tramline clutch produces a tramline	Change the calculator value as required
Leaking metering device	A foreign object in the metering device (e.g. clumped fertiliser)	Remove the foreign object and check the condition of the metering device
	Bottom flap lever damaged or loose	Adjust/repair
Fertiliser or seed shaft jerks/rotates half the time	Gearbox spring broken	Replace the spring
	Gearbox brake bearing damaged	Repair the gearbox
Surface area meters do not work	Batteries empty	Change the batteries
	Damaged sensor	Replace the sensor
	Damaged sensor cable	Replace the cable
	Sensor cable connection loose	Check the connection
Seed drill control unit screen does not start	Voltage less than 10 V	Check the power supply
	Damaged cable	Replace the cable
Seed drill control unit speed 0 km/h, even though the machine is down and driven	Friction wheel in transportation position or does not rotate	Lower the friction wheel to the seeding position and check that it rotates
	Damaged transmission	Repair the transmission
	Speed sensor magnet loose	Attach the magnet
	Sensor disconnected or incorrect distance to magnet	Adjust and attach
	Broken sensor cable	Repair the sensor cable
Track calculator does not calculate even if the machine is raised and lowered	Lifting sensor magnet loose	Attach the magnet
	Lifting sensor disconnected or incorrectly adjusted	Adjust and attach
	Broken lifting sensor cable	Replace the sensor
	Calculator stopped	Activate the calculator
Tramline calculator not displayed on screen	Tramlines disabled	Set spray width > 0 in settings
Control unit displays incorrect driving speed and surface area	Speed pulses not calibrated	Calibrate the speed measurement

Hopper guard does not alert even if hopper is empty	Alarm disabled	Activate the sensor in user settings
	Sensor adjusted too low, and the hopper bottom causes an error signal	Adjust the sensor higher
	Damaged sensor or cable	Replace the sensor
Hopper guard gives a continuous alarm	Seeds/fertilisers in the hopper below the detection limit	In small seed application, disable the hopper guard in control unit settings
Coulter arm fastening has a sideways clearance	Coulter arm joint loose	Tighten the plastic bearing of the arm fastener or replace the worn plastic bearing
Coulters in the front and rear row apply seeds at different depths	Machine not adjusted horizontal	Adjust the machine horizontal using the pushing arm
Clogged coulters	The soil is too damp	Wait for the soil to dry before seeding
	The machine is lifted or lowered when standing still or the machine is stopped without lifting the machine	Always lift and lower the machine when moving Do not stop if the machine is down
	Impurities in seeds or fertilisers	Only use clean seeds and fertilisers If required, acquire a seed hopper sieve
	Damaged coulters pipe	Repair the coulters pipe
Straws accumulate between the coulters disc and side plate	Gap between the side plate and disc	Adjust the side plates so that they touch the disc from their front/lower corner
Feed pipe gets easily blocked	Bent pipe	Straighten or replace the pipe
Smoking or noisy wheel	A foreign object in the wheel set	Remove the foreign object and check the condition of the wheel set
Hydraulics do not work properly	Ball valve closed	Open the ball valve
	Disconnected hose or incorrect connector	Connect/replace
	Maintenance support in place	Remove the maintenance support
	Half lift active	Deactivate the half lift function
Disc cultivator pulls to the side	Cultivator not adjusted correctly	Adjust the cultivator so that the front and back row have the same depth

17 ASSURANCE OF COMPLIANCE WITH EC REGULATIONS

ASSURANCE OF COMPLIANCE WITH EC REGULATIONS

Junkkari Oy
Pohjanmaanväylä 1720,
FI-62375 Ylihärmä, Finland

Here with declare on our sole responsibility that for the market produced machine

S300 seed drill from the manufacturing number S300X100001

S400 seed drill from the manufacturing number S400X100001

M300 seed drill from the manufacturing number M300X100001

M400 seed drill from the manufacturing number M400X100001

D300 seed drill from the manufacturing number D300X100001

D400 seed drill from the manufacturing number D400X100001

is manufactured, where applicable, in conformity with provisions of the instructions of the normative document according to the following directive: 2006/42/EY.

JUNKKARI OY

Kauhava 18.11.2014



Harri Hytönen
Managing director

Tarmo Kukkola is authorized to collect the technical construction file of the machine.

Tarmo Kukkola
R&D Manager

Junkkari Oy, Pohjanmaanväylä 1720, 62375 Ylihärmä, Finland

Tel +358 10 480 2534

Mob +358 44 289 8979

tarmo.kukkola@msk.fi

www.junkkari.fi

ORIGINAL

Junkkari
Part of the MSK Group

A GOOD WAY TO
**WORK
HARD**