

# Junkkari

◆◆◆  
**MAESTRO**

**COMBINED SEED  
AND FERTILIZER DRILL**

**MAESTRO**<sup>3000</sup>

**MAESTRO**<sup>4000</sup>

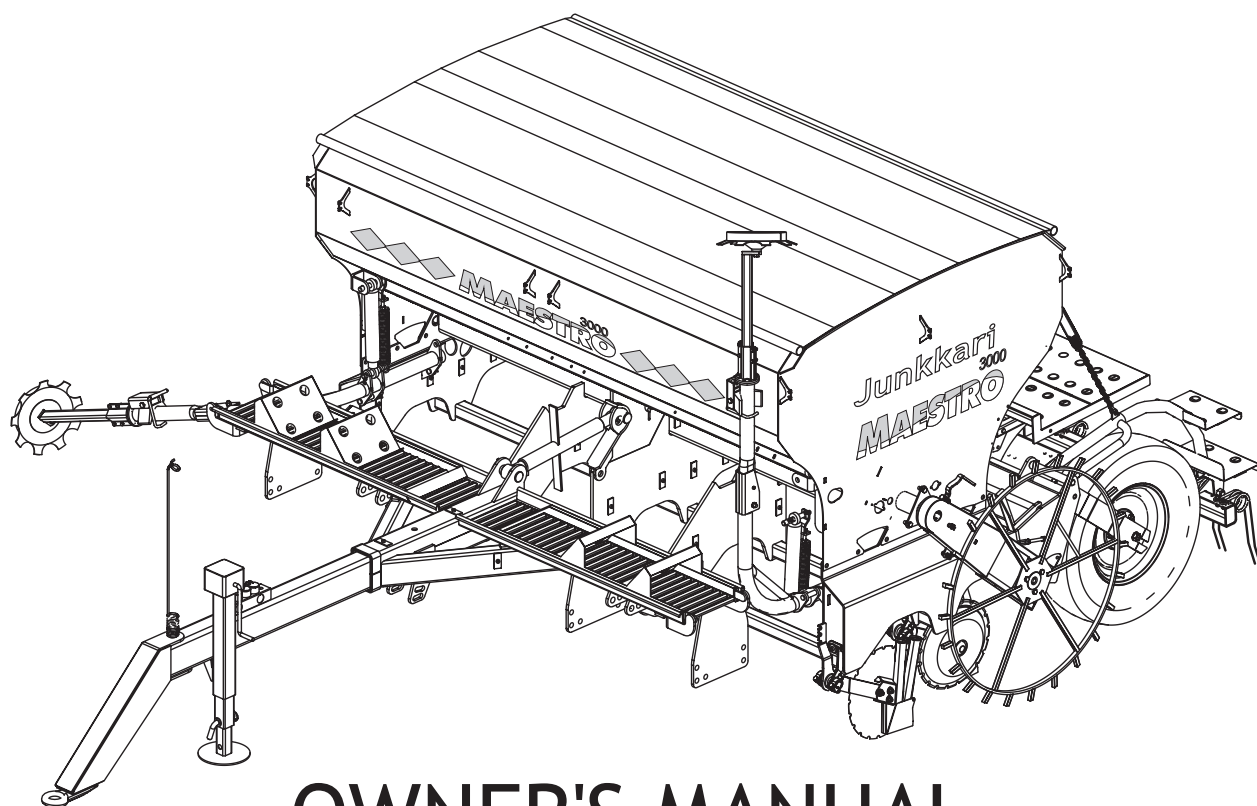

## OWNER'S MANUAL

MA09\_40\_EN

Junkkari Oy  
62375 YLIHÄRMÄ FINLAND  
TEL. +358-(0)6-4835111  
FAX +358-(0)6-4835295  
e-mail: junkkari@msk.fi  
Internet: www.junkkari.fi

ENGLISH 

# 1 CONTENTS

	PAGE
2. DEAR CUSTOMER.....	3
3. TECHNICAL SPECIFICATIONS.....	3
4. SAFETY INSTRUCTIONS.....	5
4.1 GENERAL SAFETY INSTRUCTIONS.....	5
4.2 TRANSPORT AND MOVING.....	5
4.3 MAINTENANCE AND REPAIRS.....	6
4.4 HYDRAULICS.....	6
4.5 CLEANING.....	6
5. WARNING LABELS, SAFETY COMPONENTS AND TYPE PLATE.....	7
5.1 WARNING LABELS.....	7
5.2 REFLECTORS AND LIGHTS.....	9
6. OPERATING ENVIRONMENT.....	10
6.1 OBJECTIVE OF DESIGN.....	10
6.2 LIMITATIONS OF USE AND FORBIDDEN USES.....	10
7. OPERATING PRINCIPLE.....	10
8. TRANSPORT, HANDLING, AND STORAGE OF THE MACHINE.....	11
8.1 TRANSPORTATION.....	11
8.2 HANDLING.....	11
8.3 STORAGE.....	11
8.4 SPECIAL SAFETY INSTRUCTIONS FOR MACHINE TRANSPORTATION.....	11
9. TAKING THE MACHINE INTO USE.....	12
9.1 PUTTING THE MACHINE IN WORKING ORDER .....	12
9.2 DELIVERY PACKAGE.....	12
9.3 CONNECTING THE MACHINE TO A TRACTOR.....	13
9.4 ASSEMBLY AND INSTALLATION .....	14
9.5 DISPOSING OF THE PACKAGES .....	17
9.6 TRACTOR FRONT WEIGHTS.....	17
10. EQUIPMENT.....	18
10.1 COULTER SET.....	18
10.1.1 DRILL COULTERS.....	18
10.1.2 DRILL COULTER ADJUSTMENT DEVICE .....	18
10.2 PLATFORMS.....	19
10.3 WIZARD SEED AND FERTILIZER DRILL CONTROLLER.....	20
10.4 FOLLOWING HARROW.....	20
10.5 METERING DEVICES.....	21
10.6 ROW MARKER.....	22
10.7 TRAMLINE MARKER.....	23
11. ACCESSORIES.....	24
12. USE AND CONTROL OF THE DIRECT DRILL.....	25
12.1 BEFORE SOWING.....	25
12.1.1 WORKING POSITION OF THE MACHINE.....	25
12.1.2 WORKING DEPTH.....	25
12.1.3 SUPPLIES PACKAGE.....	25
12.2 CALIBRATION TEST.....	26
12.2.1 FERTILIZER.....	26
12.2.2 SEED.....	30
12.3 TRIAL RUN FOR CALIBRATION.....	35
12.4 HOPPER CAPACITIES.....	36
12.5 SOWING.....	37
12.6 USER MANUAL FOR THE SEED DRILL CONTROLLER.....	38
13. MAINTENANCE .....	59
13.1 LUBRICATION.....	59
13.2 CLEANING AND STORAGE DURING SEASON OF USE.....	59
13.3 REPAIRS YOU CAN DO YOURSELF.....	60
13.4 WIRING DIAGRAMS.....	64
14. LUBRICATION CHART .....	68
15. CLEANING AND STORAGE.....	71
15.1 CLEANING.....	71
15.2 STORAGE.....	71

16.	TROUBLESHOOTING CHART.....	72
17.	WITHDRAWAL FROM ACTIVE USE.....	75
18.	TERMS OF GUARANTEE.....	76
19.	SCOPE OF LIABILITY.....	76
	USER'S OWN NOTES.....	77
	EC DECLARATION OF CONFORMITY FOR MACHINERY.....	78
	SPARE PARTS CATALOGUE.....	V1-V40

## 2 DEAR CUSTOMER

We thank you for the trust you have shown and wish you success in your work. Please familiarise yourself with this manual, because perfect knowledge of the machine, right adjustments, and careful maintenance guarantee the safety of the operator and the continuous operation of the machine on busy workdays. It is important that every section in this manual is understood and that the instructions are followed. In unclear cases, the vendor of the machine should be contacted. We hope that after you have familiarised yourself with the manual, you would return the signed guarantee certificate to the factory within 14 days of the delivery date.



### WARNING SYMBOL

In the manual, this symbol is used to indicate danger to the operator or other people close to the machine.

In addition, the symbol is used when there is a risk to the environment or property.

## 3 TECHNICAL SPECIFICATIONS

	MAESTRO 3000	MAESTRO 4000
Working width cm	300	400
Row spacing cm (seed and fertilizer in same furrow)	12.5	12.5
Row spacing cm, with separate fertilizer drill		
- seed	12.5	12.5
- fertilizer	25	25
Hopper capacity (l)	3500	4700
- seed maximum	2469	3370
- fertilizer minimum	773	1055
- seed minimum	1545	2108
- fertilizer maximum	1760	2402
Filling height cm	200	200
Tyres	7.50-16" 6ply	7.50-16" 6ply
Dry weight kg	2850	3500
Total width cm	300	400

### STANDARD EQUIPMENT

-Wizard seed drill control with:

Area meter	*	*
Speedometer	*	*
Hopper level guards	*	*
Tramline marker	*	*
Row markers	*	*
Feeder shaft guards	*	*
-Fertilizer sieve	*	*
-Seed side agitator shaft	*	*
-Platform, steps front and back	*	*
-Following harrow	*	*
-Lights and reflectors	*	*
-Spring loaded cover	*	*
-24(3000) or 32(4000) pcs combination drill coulters	*	*

## Technical specifications

### ACCESSORIES

- Small-seed/start fertilizer box \*
- Separate fertilizer coulters (12/3000, 16/4000) \*
- A front tiller with waved discs \*
- A front tiller with ploughing discs \*
- Dressing device \*
- 1 row front leveler \*
- 2 row front leveler \*
- 1 row s-tine tiller \*
- 2 row s-tine tiller \*
- Front packer \*
- Pre-emergence marker \*
- Fertilizer amount remote control (Wizard Plus) \*
- Fertilizer GPS adjustment (Profi) \*
- Memory cylinder \*

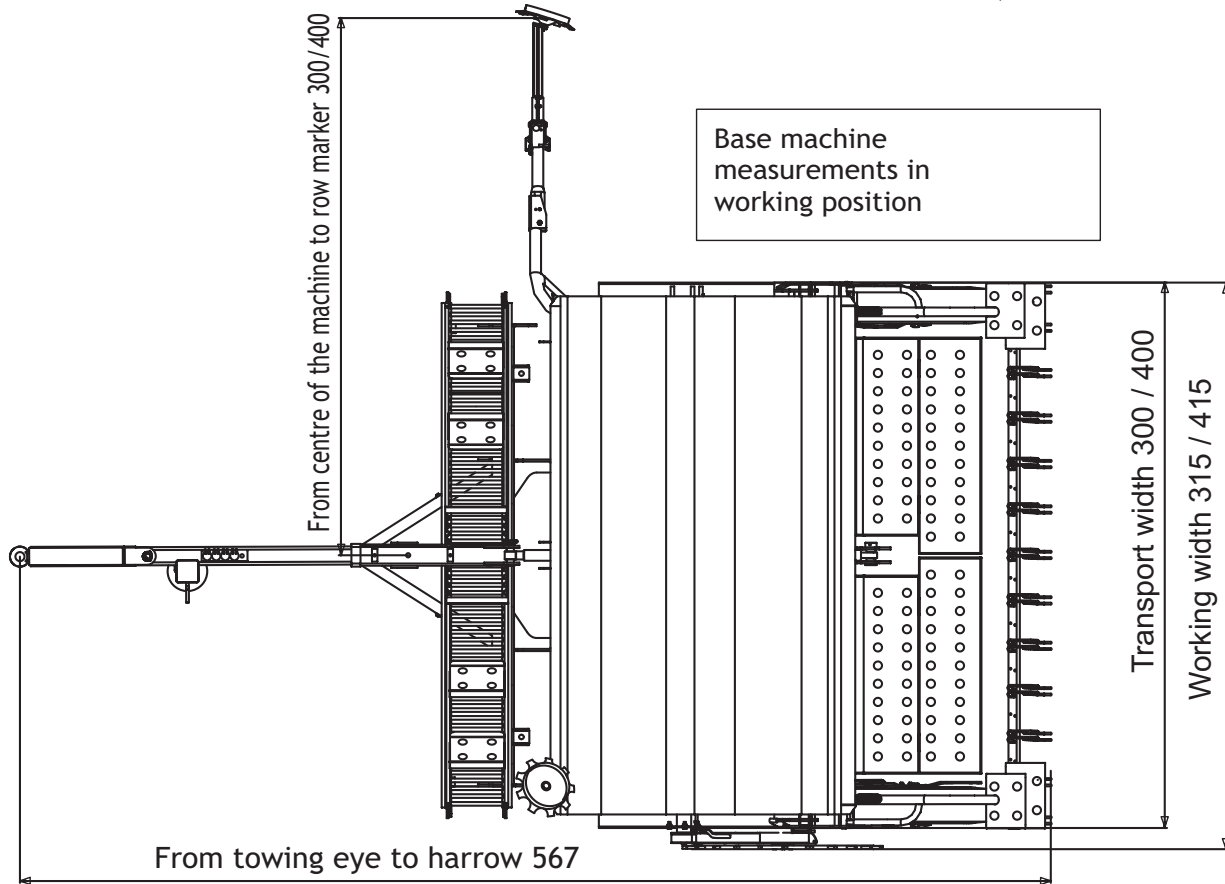
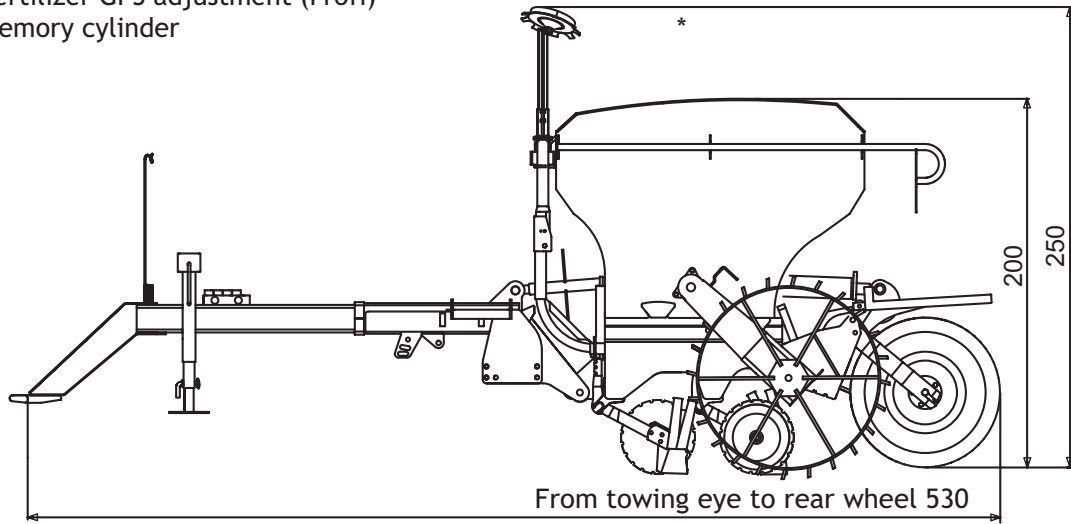



## 4 SAFETY INSTRUCTIONS



### 4.1 GENERAL SAFETY INSTRUCTIONS

- CLOTHING: Always use well-fitting clothing for the sake of safety during operation of the machine.
- OPERATION: Acquaint yourself fully with the attachment, controls and operational principles of the machine before starting to operate it.
- WARNING LABELS: Always comply with all warning labels attached to the machine at various points.
- SHIELDS: The machine must have all its shields and covers in place before you attempt to operate it.
- ATTACHMENT TO TRACTOR: Exercise special caution when attaching the implement to or when detaching it from the tractor.
- HITCH LOAD: Always note the maximum load limits on the draw bar or on the tractor hitch.
- SUPPORT BRACKET: There is a danger of crushing when installing the support bracket.
- PARKING: Ensure that the machine cannot move while parked.
- SAFETY DISTANCE: The machine employs certain components which, due to the nature of the machine's operation, cannot be fully shielded. A safe distance from these working parts must always be maintained. The operator must also take care that no outside person(s) can approach these components during the machine's operation.
- OPERATION: No outsiders must be allowed to be near or on top of the machine while it is running.
  - Never go into the space between the machine and the tractor when the machine is either being lifted up, lowered down or being transported around.
  - Never bend under or lean over the top of a machine which is being supported above the ground by tractor hydraulics only.
  - Ensure each time before taking the machine into use that it has been correctly attached to the tractor and that all its protective shields are in place.
  - Before starting to move the machine, always check that all outside persons are within a safe distance away from it.
  - Inspect the machine after each operating run, especially its hitching and other connection points.
  - In case the machine is fitted with disinfectant treatment applicator, ensure that the instructions given by the manufacturer of the disinfectant are followed throughout the operation.
  - Extra seed or fertilizer must not be carried on top of the machine covers or on the foot board.
  - Never overload the drill. Acquaint yourself with partial emptying techniques of large bulk sacks.
  - Be careful not to damage the covers with freely swinging large bulk sacks while lifting them.

### 4.2 TRANSPORT AND MOVING

- The maximum towing speed for the drill is 30 kph (18.7 mph).
- Always abide by the traffic laws when you are driving on public roads.
- Check and install all the equipment necessary for transport on the public roads, such as lights and reflectors and the slow-moving vehicle marking.
- Check the allowed axle loads, total loads and the overall transport dimensions.
- Lock the row markers in transport position and fasten the cover to the tank with rubber fasteners in all corners. Also turn the hydraulics ball tap to the closed position.
- Towed or mounted implements and extra weight on the tractor can influence its behavior during transportation, especially its steerability and brakeability. It is therefore important that both steerability and brakeability be retained at all times.
- No passengers may ride on the machine.
- The machine must be lifted only from lifting points marked by the labels on the machine
- If the machine is transported, for example, on a platform, ensure that it is securely fastened using, for example, suitable straps, slings or chains.
- When loading with a forklift or similar, care should be taken that the machine is in balance and there is no risk of falling.

## 4.3 MAINTENANCE AND REPAIRS

- Before attempting any cleaning, lubrication, fitting or adjustment of the machine, always make sure first that the tractor hydraulics are disengaged and the tractor engine switched off. Remove the tractor ignition key from the starter switch to prevent any unintentional starting of the tractor or the implement.
- Support the machine properly before you start any maintenance work on it. Use the maintenance support placed on the lift cylinder arm when doing maintenance work. The support fits in place only, when the machine is lifted into transport position. Also close the lift cylinder hydraulics hose ball tap.

## 4.4 HYDRAULICS

- The maximum pressure in the hydraulic system is 210bar.
- High pressure is induced into the machines hydraulic system after it is coupled to the tractor system. A jet of high-pressure hydraulic oil penetrates skin and causes grave injury. A danger of injury exists even when looking for oil leaks.
- Handle oil hydraulic components and parts with extreme care. The nature of the equipment will always present a danger of cuts or crushing action.
- Hydraulic couplings must not be detached when the machine is only supported by the hydraulics, because pressure remains in the system. Use the maintenance support, if needed.
- When connecting the machine's hydraulic system to the tractor system, both systems must be unpressurized. (the ball valve must be closed!).
- During transport, close the lift cylinder hydraulic hose ball tap if there is the slightest chance that the tractor hydraulic valve is leaking. You can also use the lift cylinder maintenance support.

## PROTECTION AGAINST OIL AND GREASE

- When handling oil or grease, wear appropriate protective clothing and oil-proof gloves.
- Avoid skin contact with oil and grease, because they may cause skin injury.
- Never use oil or lubrication grease for cleaning skin! These substances may contain tiny metal particles that cause cuts in the hands, and the oil makes the wounds even worse.
- Follow the handling and safety instructions of the lubricant manufacturers.
- Many synthetic oils are corrosive and cause strong skin irritation.

### WASTE OIL

- Waste oil must be collected and taken for appropriate disposal according to national regulations.

### ACCIDENTS

- If oil spills on the ground, it must be prevented from spreading and the oil must be collected by, for example, absorbing it to peat.
- If oil or lubrication grease causes injury on the skin, contact a the nearest physician immediately.

## 4.5 CLEANING

- The seed and fertilizer drill must always be cleaned before changing to another type of seed or fertilizer.
- In case the machine is stored over night or a long period of rain, the fertilizer hopper has to be emptied and feeding rolls must be cleaned from any residual material by moving the feed rate adjustment from one extreme position to the other.
- Do not spray water to electric parts.
- If any detergent is used, always ensure its suitability and follow manufacturers instructions.

NOTE THAT THE MACHINE IS MEANT TO BE OPERATED BY A COMPETENT OPERATOR AND THE USE OF THE MACHINE REQUIRES SUFFICIENT KNOWLEDGE AND SKILLS IN FARMING.  
IN EXTREMELY DAMP CONDITIONS CONSIDER OPERATING WITH PARTLY FILLED TANKS.



USE THE MAINTENANCE SUPPORT PLACED ON THE LIFT CYLINDER PISTON ROD IN ALL MAINTENANCE AND ADJUSTMENT WORK!

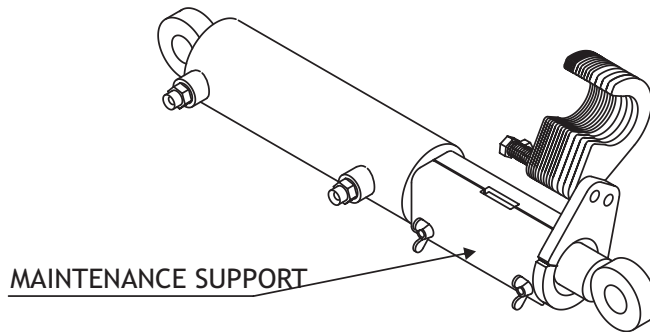

## 5 WARNING LABELS, SAFETY COMPONENTS AND TYPE PLATE

### 5.1 WARNING LABELS

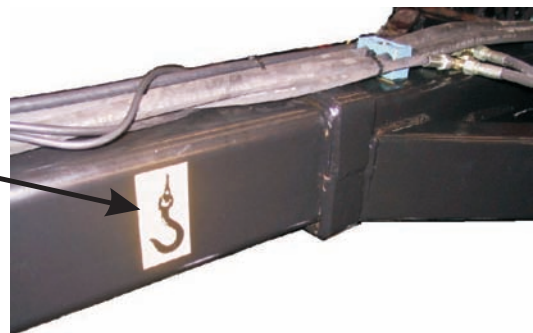

NOTE! THE OTHER LIFTING POINT OF THE MACHINE IS ON THE TONGUE, AND THE MACHINE MUST ALWAYS BE LIFTED FROM BOTH OF THE LIFTING EYES SIMULTANEOUSLY!

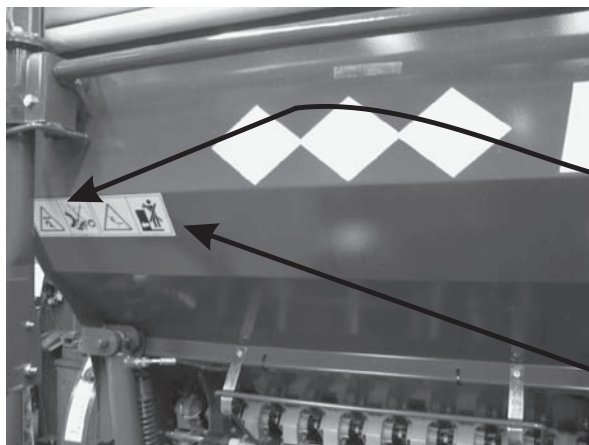

IT IS FORBIDDEN TO GO UNDER THE MACHINE



TRANSPORTING PASSENGERS IS FORBIDDEN



BEWARE OF FALLING BOOMS



DANGER OF SQUEEZING

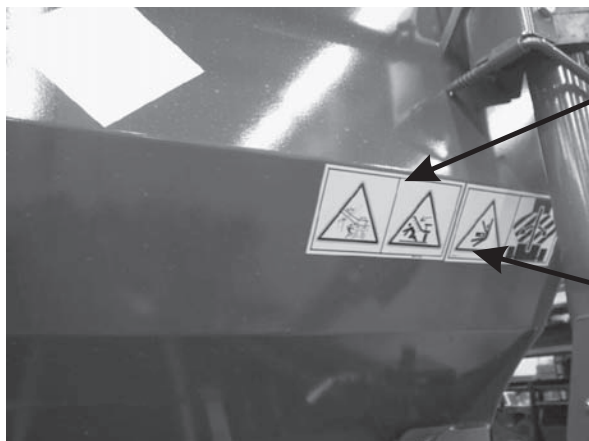

Warning stickers, safety components and type plate

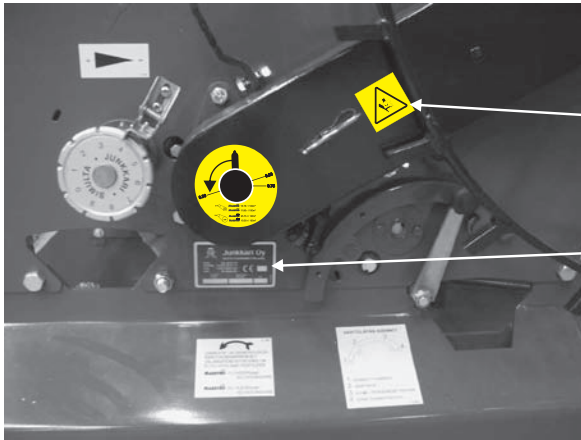

**TYPE PLATE**  
 1. CE marking attachment year  
 2. Machine type  
 3. Serial number and model year  
 4. Machine weight without equipment  
 5. The party attaching the CE marking

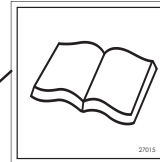
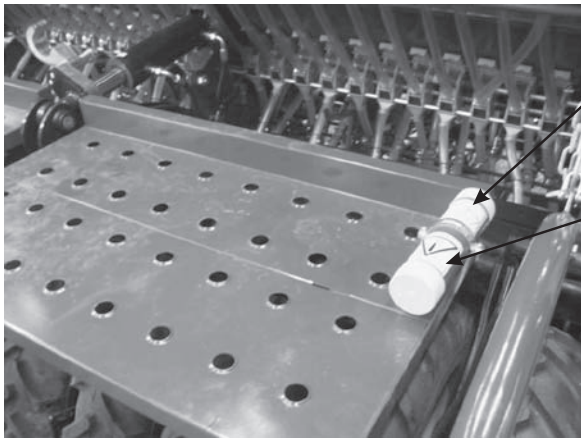
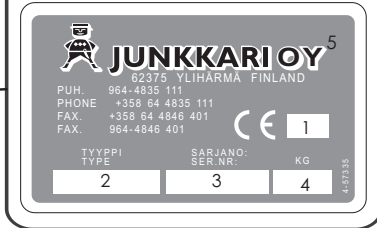

INCLUDES MANUAL



NOTE

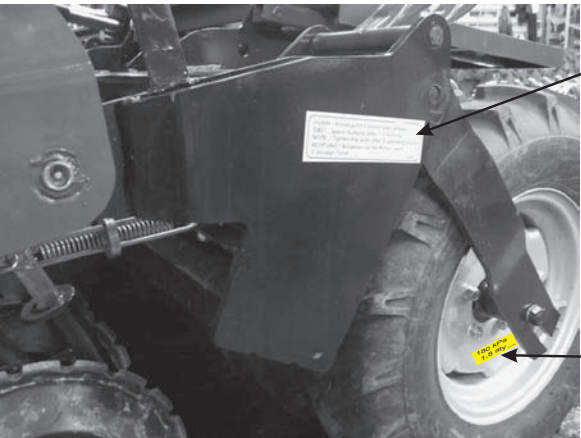

**HUOM:** Kiristä pultit 3 tunnin ajon jälkeen.  
**OBS.:** Spänn bultarna efter 3 timmar körning.  
**NOTE:** Tighten bolts after 3 hours of operation.  
**ACHTUNG:** Bolzen nach 3 Stunden Fahrt festziehen.

**180 kPa**  
**1,8 aty** 4-17959

TYRE PRESSURE



Lue käyttö- ja turvallisuusohjeet aina ennen käyttööntoitoa.  
 Läs bruksanvisning och säkerhetsföreskrifter innan den nya maskinen tas i bruk.  
 Become familiar with the owners manual and safety instructions before starting to operate this machine.



## 5.2 REFLECTORS AND LIGHTS

### REFLECTORS AND WARNING STRIPES

Towed machines should have triangular reflectors reflecting red light in the back. (Reflector 1).

The reflectors directed forward should be white in colour and they must not be triangular in shape (Reflector 2).

There should be yellow rectangular reflectors on the sides of the machine. The number of reflectors depends on the length of the machine (Reflector 3).

Towed machines should always have a slow-moving vehicle triangular reflector (Reflector 4).

On the sides of the machine, there should be red and yellow stripes visible both forwards and backwards (Stripes 1 and Stripes 2).

The reflectors and warning stripes required by the traffic laws are standard equipment in Junkkari Maestro seed drills.

### LIGHTS

The Junkkari Maestro seed and fertilizer drills have as standard equipment the lights required by the traffic laws. The lights are attached to a rack designed for them. The wiring connectors are designed to fit in each other only the right way, which prevents problems with turning signals, for example.

The lights are connected to the tractor power socket with a standard 7-pin connector.

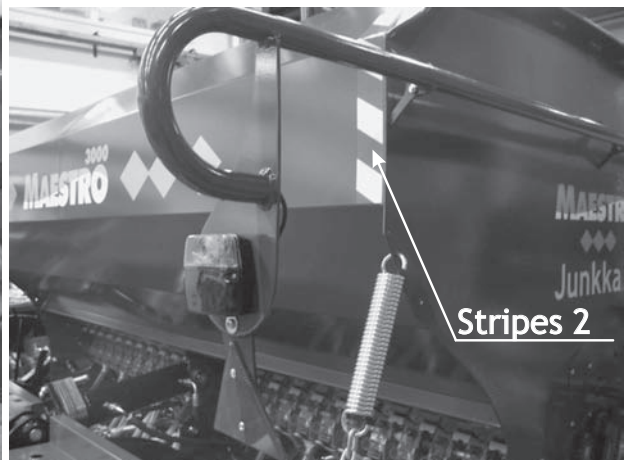
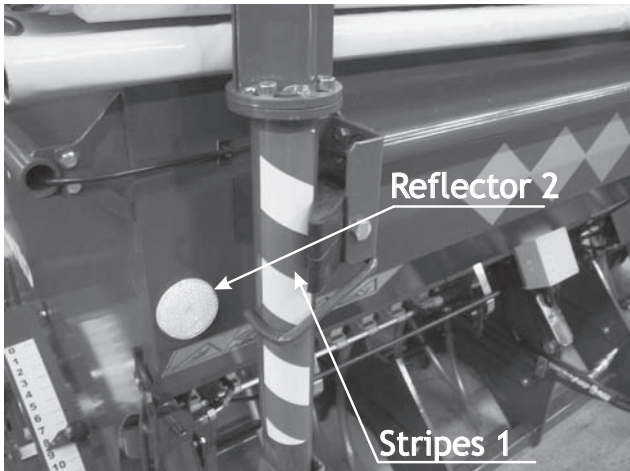
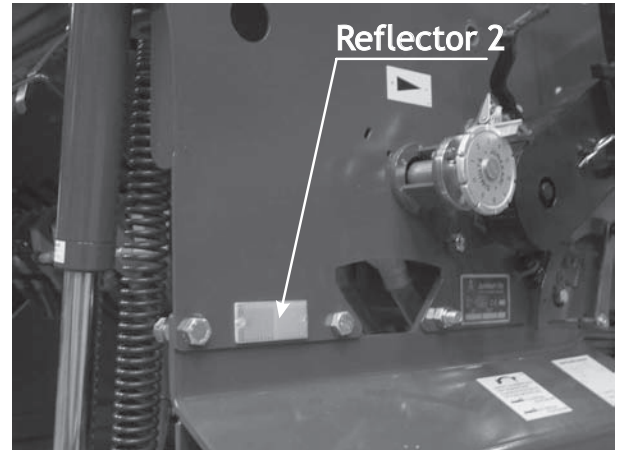
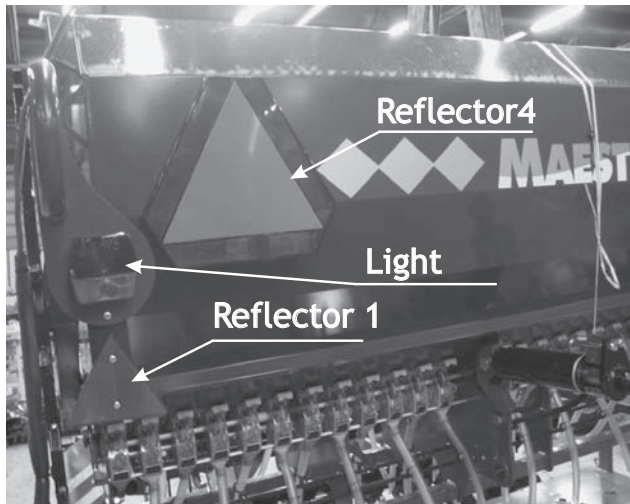

## 6 OPERATING ENVIRONMENT

### 6.1 OBJECTIVE OF DESIGN

The Junkkari Maestro seed and fertilizer drill is designed for the simultaneous sowing of seeds and granulated fertilizer as a basic machine. With basic equipment, the Junkkari Maestro sows the seed and the fertilizer in the same row with a 12.5 cm row spacing and rolls the surface soil over the seed and, if needed, harrows the soil. If you wish to sow the seed and the fertilizer traditionally in separate rows, it is possible to equip the machine with a separate fertilizer coulter set with a 25 cm row distance. In this case the seeds are sown through the basic drill coulters. Thanks to a plentiful supply of accessories, it is possible to equip the machine to fit almost any farm or type of soil. (See page 4, accessories)

A Junkkari Maestro seed and fertilizer drill with standard equipment is ready for sowing prepared, lightly prepared and even unprepared ground. By using the different optional equipment and accessories, the machine features can be changed to fit several different conditions and uses. The most suitable use for a piece of equipment is presented in the introduction of each accessory and piece of optional equipment.

### 6.2 LIMITATIONS OF USE AND FORBIDDEN USES



#### *Limitations set for the operator*

The operator of the seed and fertilizer drill may not be under the influence of narcotic substances, alcohol or strong medication.

In case of illness or disability, the attending physician can give the permission to operate the machine. Use of the seed and fertilizer drill is forbidden from people without the appropriate knowledge and skills in farming, and from children under 15 years of age.

#### *Limitations of the operating environment*

Avoid using the machine in such, especially wet or dry, conditions, where it is not possible to ensure that the seed receives a suitable amount of moisture.

#### *Forbidden uses*

The machine may not be used in a water protection zone, or on other areas designated for nature conservation. It is forbidden to spread liquids, flammable substances, sand, or powdery or fibrous substances with the machine.

Position A of the coulter pressure adjustments may only be used when the adjustment handle of the dual spring mechanism is in position 1. This position is used when you want the lowest possible coulter pressure, for example, when sowing rape (see page 18).

## 7 OPERATING PRINCIPLE

In the Junkkari Maestro seed and fertilizer drill, there is a double-studded roller in the seed side feeding mechanism, the feed amount of which is adjusted by changing the rotation speed of the studded roller with a gear box in the machine. The fertilizer side feeding device is of a rifle type, where the feed amount is adjusted by changing the efficient length of the rifle, either with the adjustment wheels on the left side of the machine, or with a remote control device available as an accessory. The feeding device gets its power from the ground wheel. The power is transmitted to the feeding device through one roller chain and the cardan shaft going through the machine. The seeds and the fertilizer flow through the delivery tubes to the drill coulters, which plant them to the set depth. The working depth of the drill coulters is adjusted either by changing the stressing of an

Individual coulter or centrally, with the laminated plates on the machine lift cylinder piston rod. The rear wheels of the machine also function as press wheels, because their textured surface prevents the soil from forming a crust. The seed and fertilizer drills have an afterharrow as standard equipment, which in traditional sowing sorts the airy layer of soil on top of the seeds and prevents in this way the moisture from rising to the surface so that the sun does not dry the soil too much.

## 8 TRANSPORT, HANDLING, AND STORAGE OF THE MACHINE

(IMPORTER, CENTRAL FIRM, RETAILER)

### 8.1 TRANSPORTATION

- The term of delivery for the product is ex works, unless agreed otherwise.
- The buyer (central firm) agrees with the manufacturer on a time when the product is ready to be called for.
- The manufacturer takes care of loading the product.
- During the transport, the transport company is responsible for the product.

### 8.2 HANDLING

- The product must be carefully handled in a usual way for agriculture machines, and the product must not be damaged.
- No other products may be loaded on top of the product.
- The product is packaged carefully when it is dispatched from the factory.
- The transport equipment must always be attached during handling.

### 8.3 STORAGE

- The machine must be stored in normal work position, protected from sunlight and rain, on its wheels and with the drill coulters lifted off ground. Do not forget to use the maintenance support during storage.
- When storing outside, check periodically that there is no water or snow left standing on top of or inside the machine.
- Store the machine indoors for any long-term periods.

### 8.4 SPECIAL SAFETY INSTRUCTIONS FOR MACHINE TRANSPORTATION



- The machine may only be lifted from the places marked with instruction stickers (the partition wall inside the machine and tongue). There are two lifting eyes in the machine, and the machine is always lifted from both of them simultaneously.
- Before lifting the machine, make sure that the rear wheels supported by hydraulics are not in danger of falling, meaning that there is pressure in the lift cylinder and the pressure hose tap is closed.
- Make sure that the lifting device is effective and safe enough, and that there is no risk of tipping over or falling.
- The seed and fertilizer drill must not be lifted with forklift forks, but belts or chains must be used instead.
- Only use certified belts and chains.
- Always before lifting, check the condition of the belts and chains.
- Always check the lifting distance when using cranes.
- The machine must always be tied to the platform during transport.
- There is always a danger of swinging when lifting the machine. Avoid sudden movements.
- When transporting the Maestro 3000 on a public road, you must make sure that the transporting vehicle is permitted to transport an extra wide load. For transporting an assembled machine, it is recommended.

## 9 TAKING THE MACHINE INTO USE

### 9.1 PUTTING THE MACHINE IN WORKING ORDER

The client is responsible for putting the machine in working order, unless it has been otherwise agreed in the sale. If the machines are transported in containers, the importer or a representative authorised by the importer is responsible for putting the machines in standard order before delivering them to the client.

The client is also responsible for installing the accessories, unless it has been otherwise agreed in the sale. The accessories can also be factory mounted, in which case the mounting costs are added to the price of the equipment.

### 9.2 DELIVERY PACKAGE

As a normal delivery, the machine with its equipment consists of one crate. The machine is packed in plastic, and includes the following parts:

- Manual, located in a protective pipe attached to the rear foot board.
- Fertilizer sieves in place in the fertilizer tank.
- Lights and reflectors attached.
- Calibration test crank in its attachment.
- The slow-moving vehicle triangular reflector in place.
- The drawbar frame turned up + drawbar on top of rear wheels
- The top link in place.
- Following harrow, lifted up.
- Tarpaulin cover in place on top of the machine.
- Hydraulic hose support in place.
- Support legs
- Working platforms
- Wizard on-board computer packed in Styrofoam in the fertilizer tank.
- The Wizard on-board computer coupling box and sensors installed in the machine.
- Maintenance kit.

An example of the machine's packaging for crate transport:

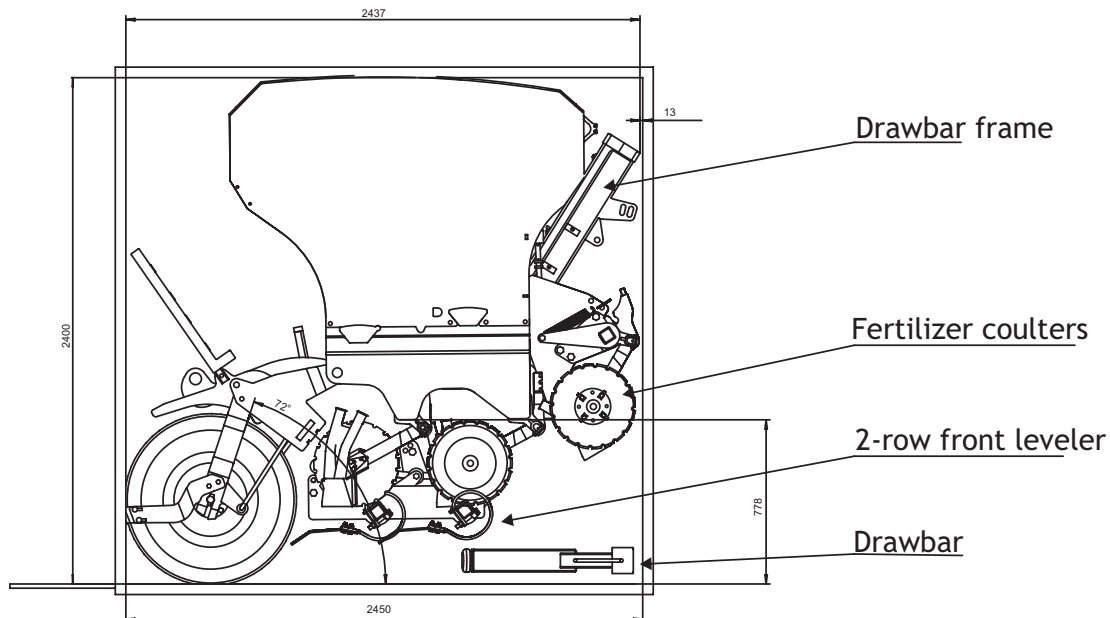



## 9.3 CONNECTING THE MACHINE TO A TRACTOR

### READ THE SAFETY INSTRUCTIONS!



The Junkkari Maestro seed and fertilizer drill is connected to the tractor towing hook (ISO 6489/1) or to the wheel interval roller available as an accessory, which is connected to the machine lift arms.

TO PREVENT THE MACHINE FROM DAMAGE AND GETTING CLOGGED, BOTH THE SEED AND FERTILIZER DRILL AND THE WHEEL INTERVAL ROLLER MUST BE LIFTED UP WHILE REVERSING.



## HYDRAULICS

The Junkkari Maestro seed and fertilizer drills require two (2) dual-function hydraulic valve blocks to function in standard equipment. If the machine is equipped with different front tillers two (2) more dual-function hydraulic valve blocks are required for each tiller.

The hydraulic row marker that comes as standard equipment with the seed and fertilizer drill and is controlled by the Wizard on-board computer, is connected to the quick-release connector ready in the seed and fertilizer drill hydraulics.

The quick-release connectors in the machines delivered to the EU area comply to the ISO 7241-1 standard.

## ELECTRIC CONNECTIONS

The lights of the machine are connected to the 7-pin light socket in the tractor. The socket must comply to the SFS 2472 DIN ISO 3732 standard.

The Wizard on-board computer supplied as standard equipment with the machine, is connected with ISO/TR 12369 compliant connectors. The nominal voltage used is 12V and they function with direct current.

The precise installations instruction for the devices are presented later in this manual or in the installation manual of each accessory.

In addition, other electric accessories are available for the machine, and the connection of these accessories is made with either DIN ISO 4165 or ISO/TR 12369 compliant connectors.

THE SEED DRILL MUST BE LIFTED UP WHILE YOU LOWER THE GROUND WHEEL, OTHERWISE THERE IS A DANGER OF CRUSHING.



Lowering down the ground wheel is done in the way shown in picture 1, when the machine is lifted up. Take hold of the pull-out handle with your left hand and of the lifting handle with your right hand. Turn the ground wheel outwards with the pull-out handle, while supporting and lowering it carefully with the lifting handle.



## 9.4 ASSEMBLY AND INSTALLATION

- Remove the protective plastic, the attachment hoops and bands from the machine.
- Check the contents of the package. If the delivery is incomplete, or there is a reason for complaint, contact the Dealer

### INSTALLING AND ADJUSTING THE FOLLOWINGHARROW

The harrow is attached to the rear wheel frame from both sides of the machine with pins, both of which are locked in the middle with a screw and a nut. The chains are attached so, that as many free links remain in both chains (PICTURE 1). The harrow working depth is adjusted by changing the length of the chain. This is necessary, because it can be used to limit the lowest position or pressure of the harrow.

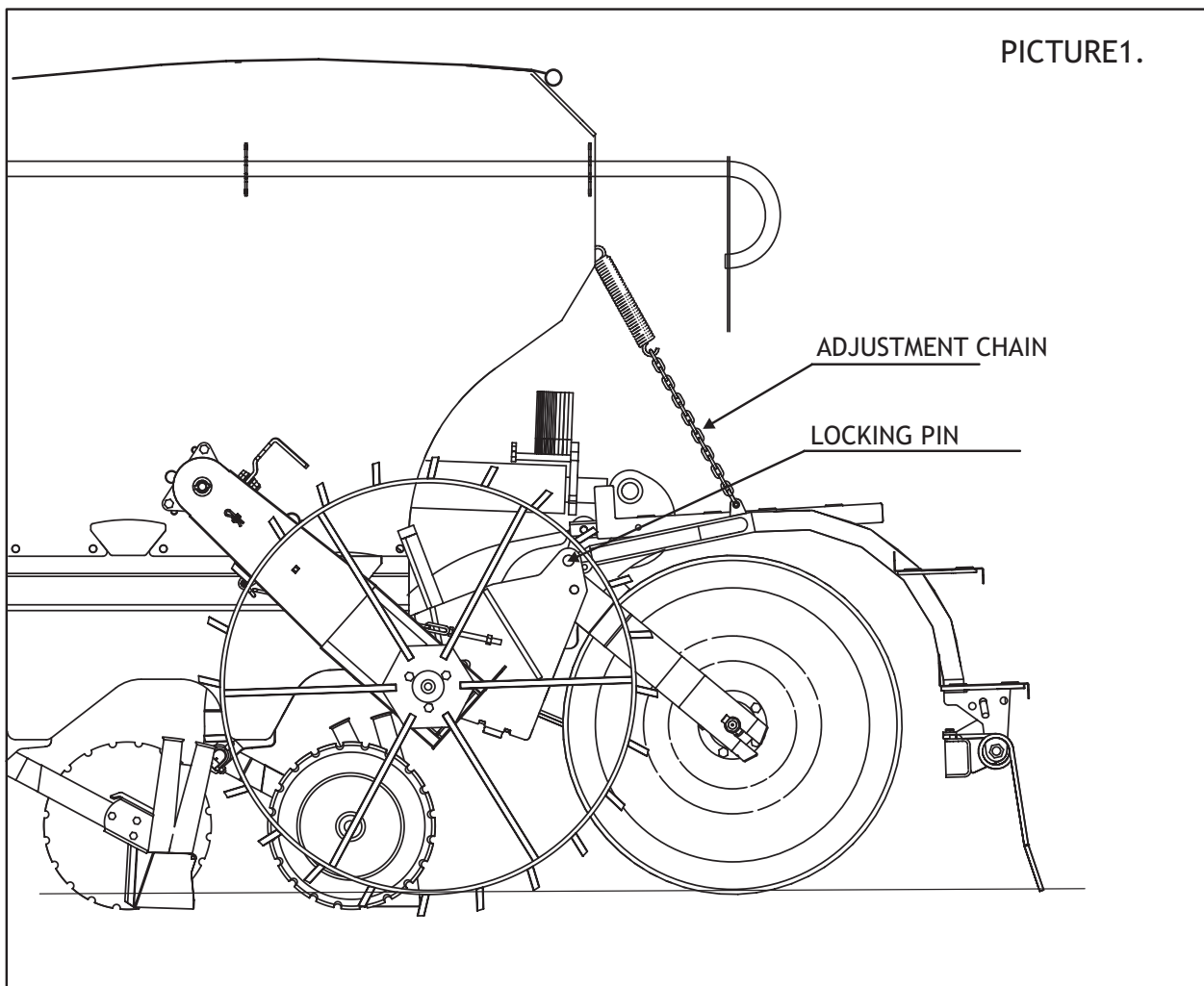

## COVER

The spring loaded cover is installed at the factory. The cover is attached to the edges of the tank with clamps. The clamps should be installed to the top level of the adjustable partition wall, which makes filling both tanks easy.

**NOTE! WHEN YOU ATTACH THE SEED SIDE COVER ATTACHMENT STRING, YOU MUST MAKE SURE THAT THE STRING DOES NOT HANG INSIDE THE TANK AT ANY POINT. THIS CAUSES A DANGER THAT THE STRING MAY TWIST AROUND THE AGITATOR SHAFT AND DAMAGE THE MACHINE. TIE THE STRING TO THE FASTENER ON THE FRONT WALL OF THE TANK.**



While moving the machine, especially on a public road, do the following:

- Attach the cover with rubber links (picture 2).
- Tie the strings carefully to the fastening buttons (picture 1).
- Lock the ground wheel in transport position (picture 4).
- Lock the row markers mechanically during transport (picture 3).

Keep the deck blanket closed during sowing, because even slight moisture in the fertilizer impedes the functioning of the seed and fertilizer drill.

PICTURE 1.



PICTURE 2.



Rubber fastener

PICTURE 3.



Row marker lock

PICTURE 4.



GROUND WHEEL LOCKING  
TO TRANSPORT POSITION

## LIGHTS

The lights are installed in the basic machine at the factory.

## DRAWBAR AND WORKING POSITION

The drawbar unit includes following parts: drawbar frame, drawbar, hydraulic hose holder and top link (picture 1). The adjustable support leg is fixed to the drawbar. The Junkkari Maestro seed and fertilizer drill works best, when the machine is adjusted close to horizontal position. Adjustment is made by adjusting the length of the top link. It is easiest to verify the horizontal position either by sight, or with a spirit level from the machine handle bar, while it is attached to the tractor (picture 2).

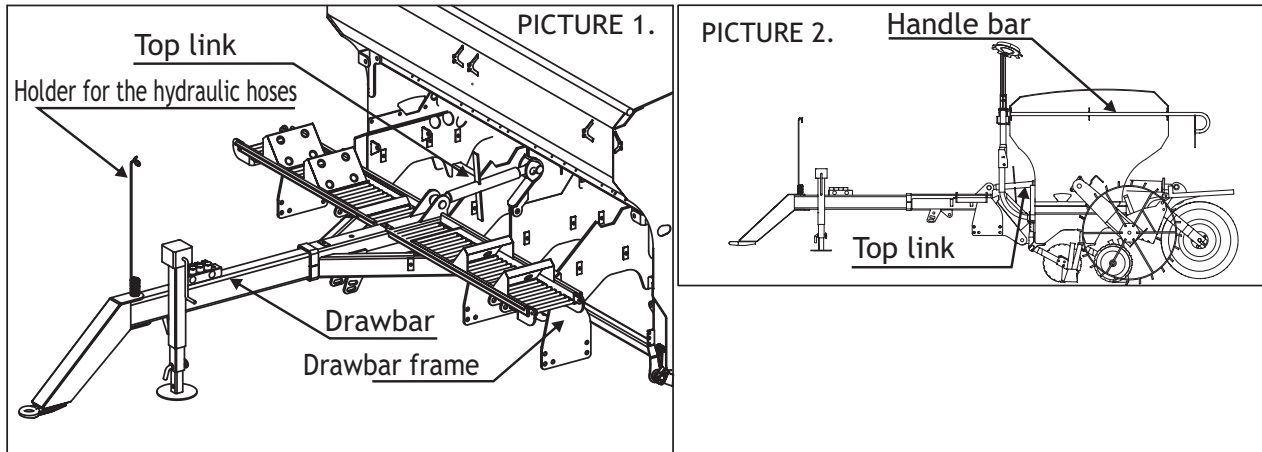

## HYDRAULICS

The lift cylinder hydraulic hose includes a ball valve, which is used to close off the oil flow. The valve is open, while the valve handle is turned into the direction of the hose. When the handle is crosswise to the hose, the valve is closed. It is recommended to close the ball valve during transportation to ensure that the machine stays in transport position. Close the valve during maintenance work.

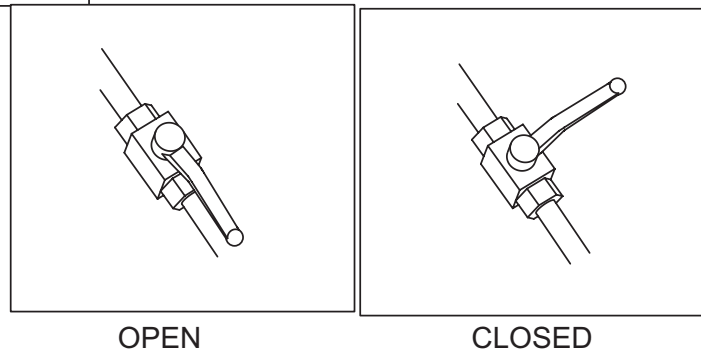

## INSTALLING THE WIZARD ON-BOARD COMPUTER

The Wizard on-board computer supplied as standard equipment with the machine is already installed in the seed and fertilizer drill at the factory. The customer is responsible for installing the monitor in the tractor, unless it has been agreed otherwise. The following pictures present some alternatives for places to install the monitor. As a general guideline, it is good to install the monitor near the controls, which allows you to benefit from the tractor's own ergonomic solutions.

The installation is made by using the monitor three-joint support. The support is attached in the cabin with the two screws in the package, in a place steady enough that it stays attached.

In addition to the data cable connected to the monitor, a power supply cable comes to the cabin and is connected to the socket intended for electric accessories of the tractor. The socket complies to the ISO/TR 12369 standard and it is common in new tractors. The socket complying to the description in the standard is designed especially for demanding farming use. If there is no such socket in the tractor, it is worthwhile to get one to ensure that the device functions without interference.

The most common cause of faults in the electric devices used in farming equipment is a power supply connector that is not in good condition.



## 9.5 DISPOSING OF THE PACKAGES

Wooden and cardboard package materials can be disposed of by burning or taking them to a landfill. The plastic bags and plastic string coming with the package should be disposed of according to national regulations by recycling or taking them to a landfill.

## 9.6 TRACTOR FRONT WEIGHTS

To get all the benefits offered to you by Maestro in the form of ease of handling and saving time, you should be able to sow it with full seed and fertilizer tanks. Before sowing season you should check that the tractor hitch is in good condition. Sometimes, especially with small tractors, the front end may be too light, in particular when driving with full tanks. In this case you should get front weights for the tractor to change the centre of gravity so, that ca. 20 % of the tractor's weight rests on its front axle.



## 10 EQUIPMENT

### 10.1 COULTER SET

The coulters set of the Junkkari Maestro seed and fertilizer drill consists of coulters and a patented dual spring mechanism which sets the pressure for each coulter individually.

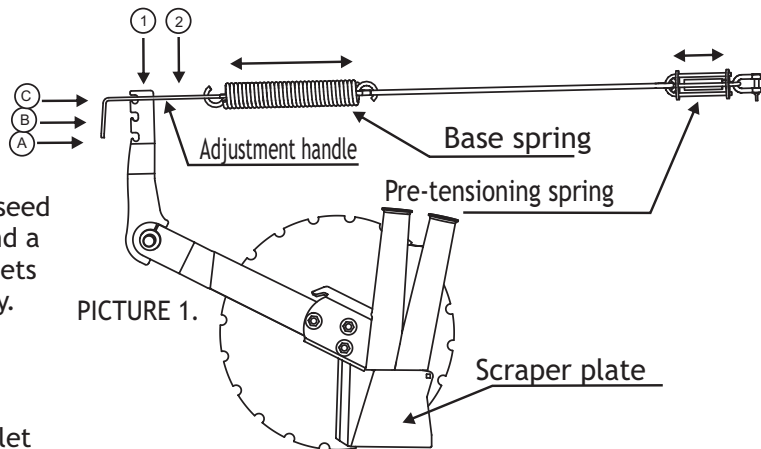

#### 10.1.1 SEED COULTERS

The coulters come equipped with two inlet tubes one for the seeds and one for the fertilizer.

If a separate fertilizer coulter set is used, the top of the inlet tube facing forward should be blocked to keep earth from jamming the coulter. Three nuts can be used to adjust the spring loaded scraper plate of the coulter to fully correspond to the coulter disc.

#### 10.1.2 SEED COULTER ADJUSTMENT DEVICE

The coulter adjustment device consists of the machine's hydraulic lifting cylinder (Picture 2) and the dual spring tensioner (Picture 1). The primary function of the lifting cylinder is to move the drill between the working and transport positions. Basic adjustment of the drill sowing depth is done by adding or removing some of the sliced sheets on the piston rod. As a general rule, if 10 mm of sheets are turned away from the piston rod, the sowing depth increases 20 mm. The sheets are attached to the piston rod with two M16 bolts. The thickness of the sheets varies, and their place can be changed if necessary.

A good starting point for adjusting the sheets is to turn 55 mm of sheets down on the piston rod. This will make the Theoretical sowing depth 40 mm (Picture 3). The final measurement of the sowing depth should be done in working conditions in the field. After measuring, fine adjustment can be easily done when the machine is in transport position.

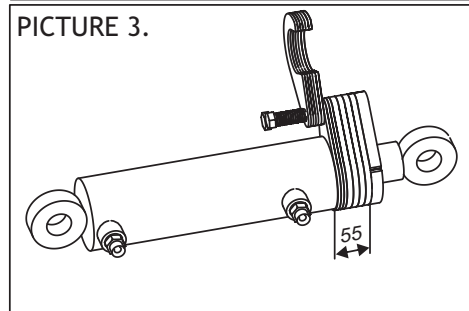
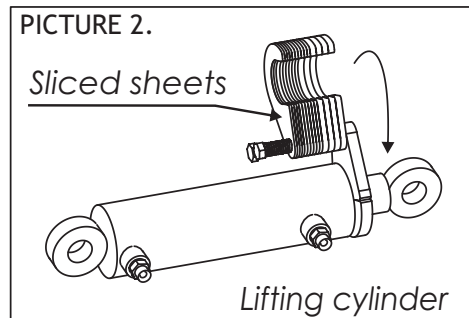

The machine must always be in the transport position (raised) when adjusting the sowing depth and coulter pressure. Close the ball valve in the hydraulic hose of the lifting cylinder and use the cylinder maintenance support during adjustment and maintenance work.



Coulter pressure can be adjusted by repositioning the adjustment handle of the dual spring mechanism. Positions 1 and 2 affect the length of the mechanism, i.e. its spring force. Position 1 is used when sowing in tilled soil. In this case the pressure (6-30 kg) is created by the pre-tensioning spring only. Position 2 is suitable for light tillage and direct sowing (35-140 kg). In this case the base spring is in use. Positions A, B and C change the length of the moment arm, which transfers the spring force to the coulter the longer the arm, the greater the coulter pressure. In other words, the highest coulter pressure can be reached with the combination 2/C (140 kg) and the lowest pressure with the combination 1/A (6 kg).

It is recommended that you adjust the sowing depth before the coulter pressure, because changing the sowing depth (the amount of sliced sheets) affects the coulter pressure as well. As the lifting cylinder, which adjusts the sowing depth, changes the position of the rear wheels in regard to the frame, and the coulter pressure mechanism functions between the rear wheels and the frame, these two adjustments are closely connected.

The chart below will help you choose the right adjustment handle position for different coulter pressures. The chart is theoretical and based on spring force.

**BASE SPRING**

**PRE-TENSIONING SPRING**

L <sub>1</sub> / mm	A B C	Coulter weight / kg	L <sub>2</sub> / mm	A B C	Coulter weight / kg
14	A	35	10	A	6
14	B	40	10	B	8
14	C	45	10	C	10
24	A	45	30	A	12
24	B	50	30	B	12
24	C	55	30	C	13
37	A	50	50	A	13
37	B	60	50	B	14
37	C	70	50	C	15
47	A	60	70	A	15
47	B	70	70	B	16
47	C	80	70	C	17
59	A	70			
59	B	80			
59	C	90			
73	A	80			
73	B	90			
73	C	100			
83	A	85			
83	B	100			
83	C	115			
94	A	95			
94	B	110			
94	C	125			
106	A	105			
106	B	120			
106	C	140			

Extensions L<sub>1</sub> and L<sub>2</sub> are measured in working position.

**NOTE!**  
Coulter pressure: Position A is not recommended.

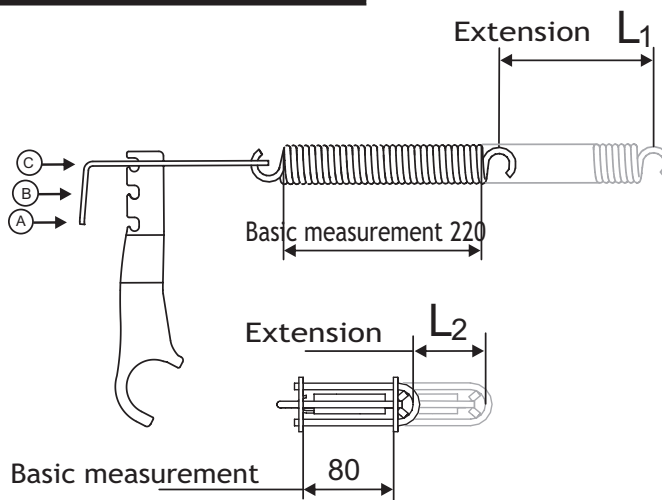

**10.2 PLATFORMS**

The Junkkari Maestro has platforms at the front and back of the machine. The rear platforms can be raised and locked in position when servicing the wheels. If a small seed/ start box has been installed in the machine, lock the rear platform in the more gentle angle when servicing the wheels. This way the platform will not strike other parts of the machine under any circumstances.

The lifting cylinder maintenance support is attached under the left platform. It should always be used when performing adjustments or maintenance work. See installation of the maintenance support on page 7.

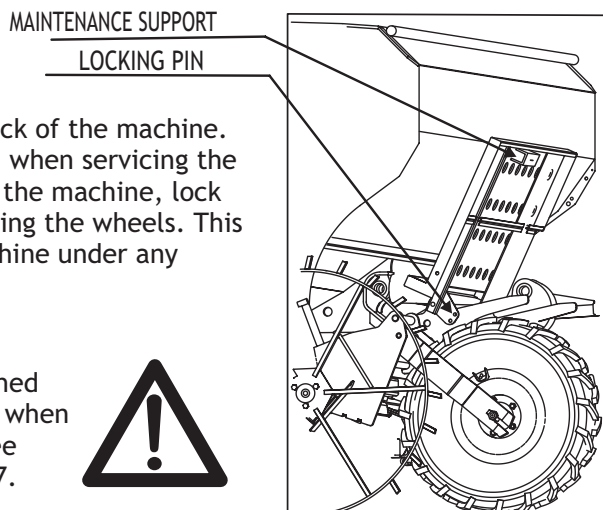

## 10.3 WIZARD SEED AND FERTILIZER DRILL CONTROLLER

Junkkari Maestro drills come equipped with an on-board computer, the Wizard seed and fertilizer drill controller. The properties of the device include:

- Speed gauging
- Area measurement: total area + trip
- Hopper guards in the fertilizer and seed hoppers
- Monitoring the rotation of the fertilizer shaft
- Monitoring the rotation of the seed shaft
- Row marker (see 10.6)
- Tramline marker (see section regarding tramline marking in the Wizard instruction manual and section 10.7)

Tramline marking is intended for later plant protection spraying.

- The device is capable of marking tram lines using four different methods:
- Symmetrical
- Asymmetrical right
- Asymmetrical left
- 18 m method

The manual for the Wizard seed and fertilizer drill controller can be found later in this manual.

## 10.4 FOLLOWINGHARROW

The purpose of the followingharrow, which is part of the drill's standard equipment, is to loosen and level the top soil above the seed row level. In addition, the harrow spreads the loose soil on top of the rolled soil and thus keeps moisture from rising to the surface of the field and evaporating.

Because the harrow is not meant for tillage, the harrow position must be adjusted so that it does not affect the sowed seed in the ground. When attaching the chains leave an equal amount of free chain links on each chain (PICTURE 1/ADJUSTMENT 1).

The working depth of the harrow can be adjusted by changing the length of the chain or with the screw (ADJUSTMENT 1).

This enables you to limit the lowest position of the harrow, i.e. the harrow pressure.

The working angle of the harrow can be easily changed to suit the prevailing conditions (ADJUSTMENT 2). You can choose from three different positions (A, B, C). In position A the spikes of the harrow are in a dragging position and, conversely, in position C the spikes are nearly vertical. It is recommended that you use the LOCKING PIN to adjust the working angle in the field, after finishing the sowing adjustments to the machine. The idea is that the harrow runs smoothly behind the seed and fertilizer drill spreading the soil left between the tire tracks on top of the tight-packed track left by the wheel.

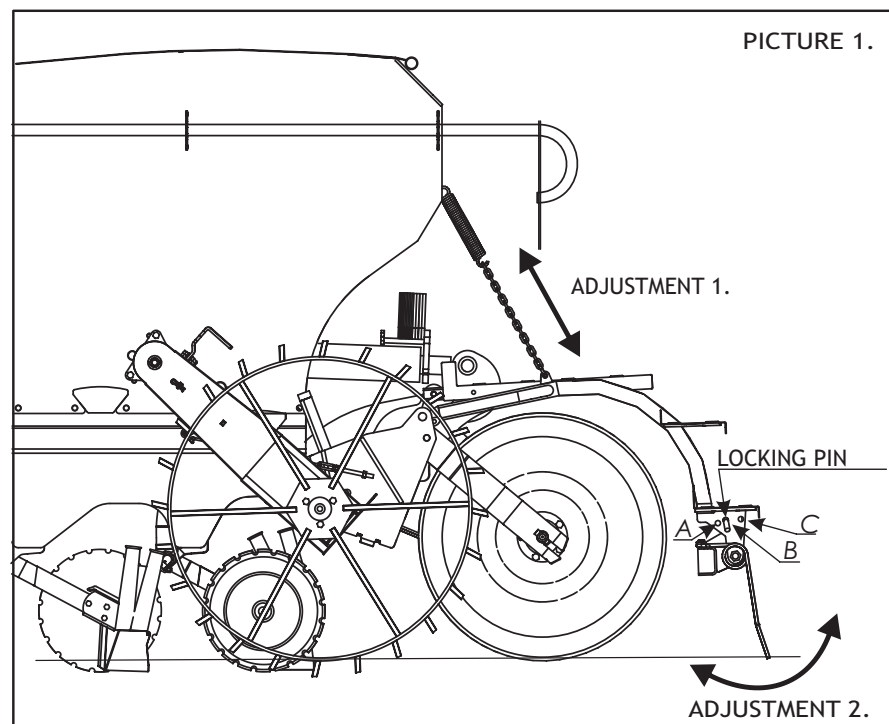



## 10.5 METERING DEVICES

### FERTILIZER SIDE

The metering devices in the fertilizer side are of a so-called push rifle type. This means that their feed amount is adjusted by changing their effective length. The feeding devices in the fertilizer side are driven by a gearwheel, which is connected to the ground wheel via a drive shaft. The shutter plate between the feeding house and the tank can be used to shut off the fertilizer feed. By shutting off some of the feeding devices the machine can be used to sow with a limited working width. If the machine has separate fertilizer coulters, every other shutter plate should be closed. A curved bottom flap is located at the bottom of the feed chamber. The bottom flap yields when necessary, if a foreign object or caked fertilizer gets in to the feeding mechanism. The position of the bottom flaps can be changed using the lever at the front centre of the machine. The lever affects all of the bottom flaps simultaneously. The second highest notch (position 1) is the normal operating position of the bottom flap lever. Using the third notch (position 2) increases the feed amount by ca. 15 %. Empty the machine by pressing the lever all the way down and turning the feed devices with the crank.

### SEED SIDE

The seed side has spiked roller feed. The feed roller consists of two separate studded rollers: the small seed roller and the normal roller. Sow small seeds using only the more narrow small seed roller. To do so, move the locking stud (PICTURE 2) in the direction of the arrow or, in other words, left. The stud can be moved with a screwdriver through the 10\*13 hole in the cover. Another way is to open the cover and move the locking stud with your forefinger. The cover must always be closed during sowing. You can open the cover by pressing in the handles in the upper portion of the cover and turning it outward simultaneously. When the locking stud has been moved to its extreme position on the left, it will stop the normal roller from rotating.

When sowing normal seeds, both rollers are used. Therefore, the locking stud needs to be moved to its extreme position on the right to allow both of the rollers to rotate.

**NOTE!** If the locking stud does not fit back to the black studded roller, turn the black studded roller one tooth either way.

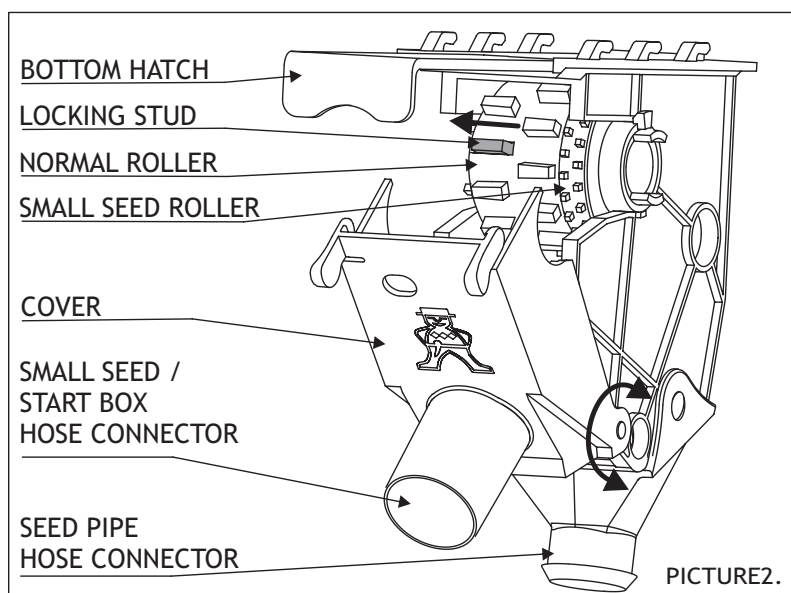

The seed side metering device has two other adjustable parts: the small flap and the bottom flap. The small flap has four different positions. The positions can be adjusted using the handle at the left end of the machine (PICTURE 1).

In position 1 the seeds left in the machine can be emptied to calibration trays. The seeds can flow unobstructed out of the tank from both sides of the studded roller. To allow for this, the bottom flap adjustment handle must be in position E.

Position 2 is for performing the calibration test. This position allows the seeds to flow to the calibration trays placed under the metering devices.

Position 3 is used for normal sowing. This position can also be used to sow small seeds from the small seed / start box directly to the surface.

In position 4 the seeds travel normally from the hopper to the ground via the coulters. In addition, start fertilizer can be fed from the small seed/start box to the same row with the seeds.

The bottom flap has four different positions for seeds of different sizes and an emptying position (E). The position of the bottom flap can be adjusted using two separate levers located at both ends of the machine (PICTURE 2). See section CALIBRATION TEST for the positions to be used with different types of seeds. The positions are also printed on the calibration test sticker on the side of the machine.

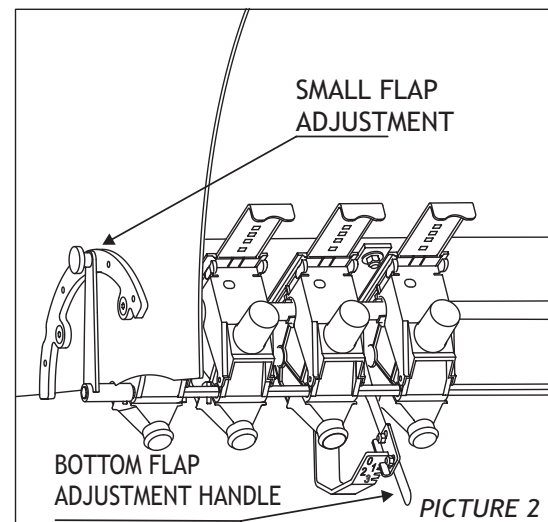
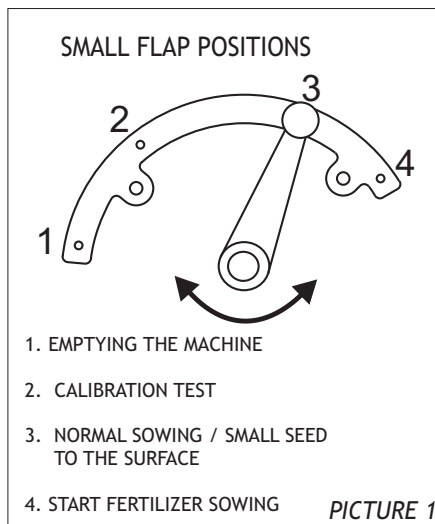

## 10.6 ROW MARKER

The hydraulic row marker on the Junkkari Maestro seed and fertilizer drill is used to mark the centre line of the driving line.

The hydraulic row marker has no other applications.

The row marker is driven by the hydraulics controlling the lifting of the drill.

The marker is used and controlled from the tractor cabin using the Wizard controller.

Use the Wizard controller to select:

- Manual/automatic marking
- Starting side of the marking/marking both sides.

The marker arms are lowered and raised according to the chosen program every time the machine is lowered or raised.

More detailed instructions for the Wizard controller can be found in section:  
12.6 USER MANUAL FOR THE SEED DRILL CONTROLLER.

The hydraulic cylinders of the row markers lift the arms when the machine is raised. The arms are lowered by spring force while the return oil of the hydraulics limits the speed of the motion.

An adjustable flow regulator valve limits the speed of the marker arm lifting motion when the seed and fertilizer drill is raised.

The rotating discs at the ends of the arms make the marks when lowered on the surface of the field. The angle of the discs can be changed to suit different types of soil. The distance of the discs from the centre of the machine should be adjusted to match the machine's working width. The marking trail can be set to be continuous on one side only, on different sides in turn or on both sides simultaneously. The row markers are equipped with breakable shear bolts, which protect the frame structures when the machine hits an obstacle. The machine has M6 shear bolts as part of the standard equipment, but if the M6 bolts keep breaking due to an aggressive driving style or an uneven sowing ground, the row markers have slots for M8 bolts as well. M8 bolts are not part of the standard equipment.

**NOTE!** It is recommended that you not adjust the discs to an excessively steep angle, since this puts unnecessary strain on the row marker structure.

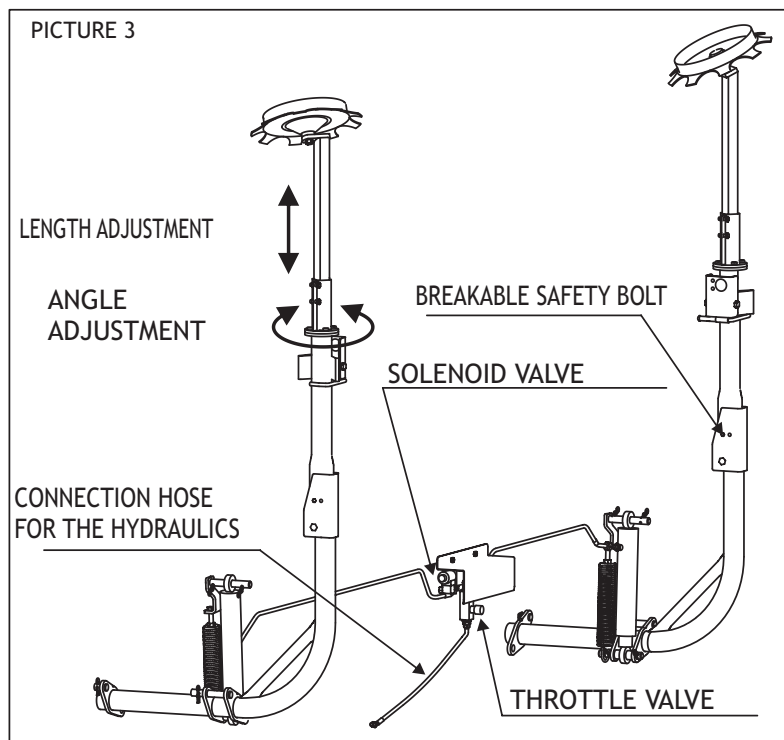

## 10.7 TRAMLINE MARKER

The tramline marker marks the line for later plant protection spraying. This means that, within the chosen track width, two coulters are left unsown on both sides of the machine. The marker is used and controlled from the tractor cabin using the Wizard controller.

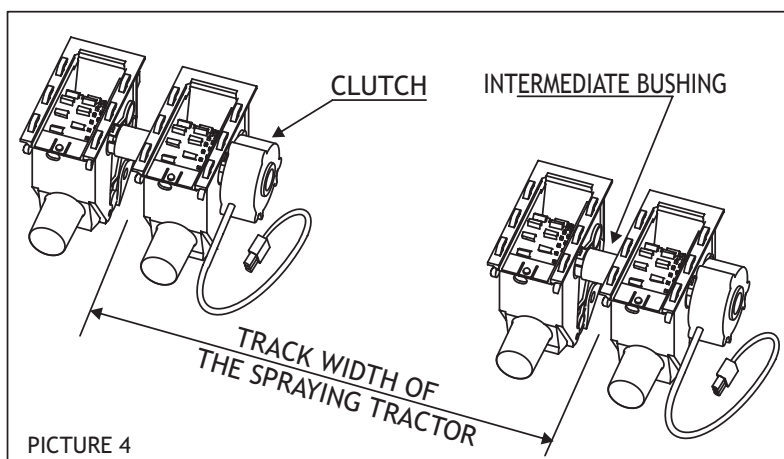

More detailed instructions for the tramline marker can be found in section: 12.6 USER MANUAL FOR THE SEED DRILL CONTROLLER.

# 11 ACCESSORIES AND SPARE PARTS

## ACCESSORIES

A large number of accessories are available for the Maestro drill. They can be used to equip the machine to suit most farms and sowing methods. Ask your Maestro dealer about these accessories.

The basic machine can be equipped with the following accessories:

- Small seed / start fertilizer device
- Separate fertilizer coulter set (Maestro 3000/12 coulters, Maestro 4000/16 coulters)
- Front tiller with waved discs
- Front tiller with ploughing discs
- Dressing device
- 1 row front leveler
- 2 row front leveler
- 1 row s-tine tiller
- 2 row s-tine tiller
- Front packer
- Pre-emergence marker
- Fertilizer remote controller (Wizard Plus)
- Fertilizer GPS adjustment (Profi)

Each accessory is supplied with instructions for assembly and installation. If a spare part list cannot be found in this manual, it comes with the instructions for the accessory. Attach the installation instructions as an appendix to this manual.

## SPARE PARTS

When ordering spare parts:

- Define the type of the machine and year when it was manufactured.
- You will also need to specify the designation and number of the part.

## 12 USE AND CONTROL OF THE DIRECT DRILL

READ THE SAFETY INSTRUCTIONS BEFORE USING



### 12.1 BEFORE SOWING

#### 12.1.1 WORKING POSITION OF THE MACHINE

Before beginning, the push arm of the machine must be adjusted so that the machine runs as straight as possible at the chosen depth.

SEE section 9.4 DRAWBAR AND WORKING POSITION page 16.

#### 12.1.2 WORKING DEPTH

The working depth can be adjusted with the sliced sheets that can be placed on the lifting cylinder piston rod.

Adjustment is not required during sowing, because the wedge roller type disc coulters maintains the depth at a constant level.

SEE section 10.1.2 SEED COULTER ADJUSTMENT DEVICE

#### 12.1.3 SUPPLIES PACKAGE

The machine is delivered with a supplies package that includes the parts listed below. During transportation, the parts are in the fertilizer tank on top of the fertilization sieves.

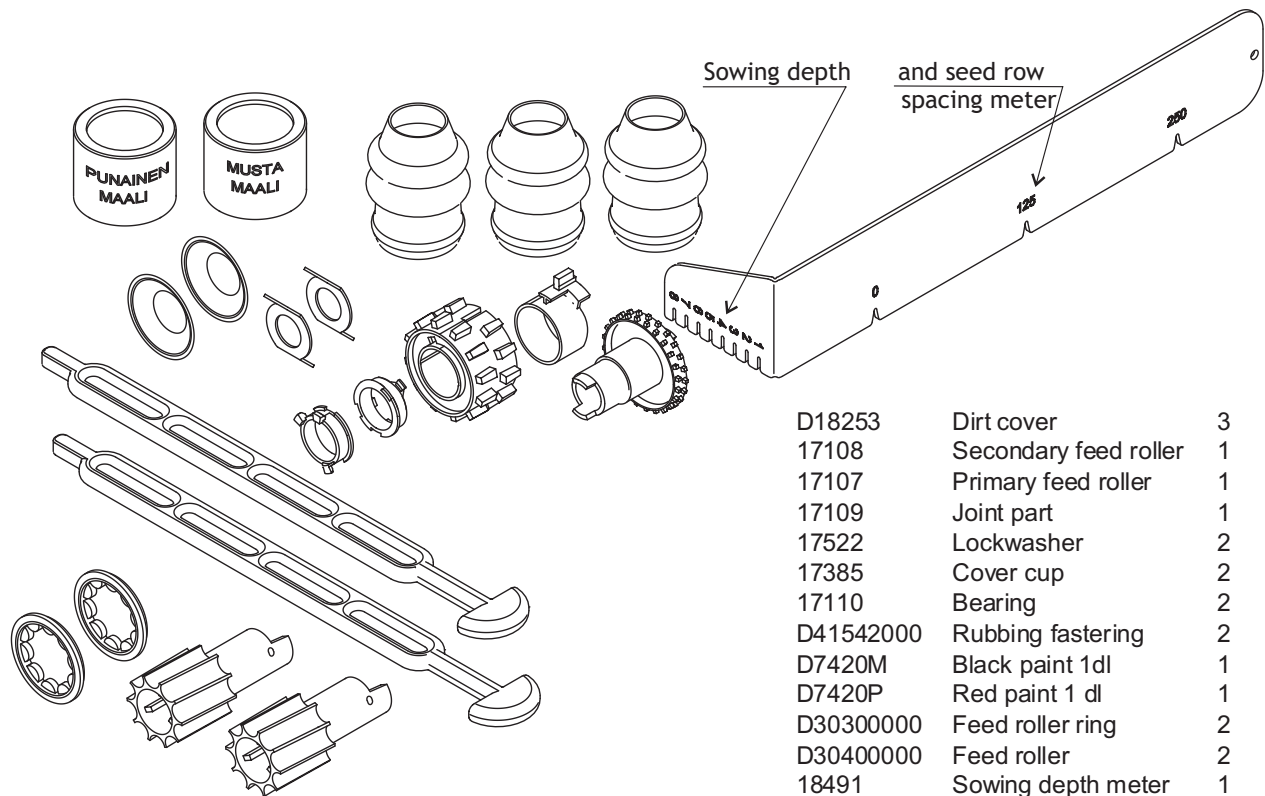

## 12.2 CALIBRATION TEST

### 12.2.1 FERTILIZER SIDE

Always perform the calibration test with the machine raised and the ground wheel in transport position (PICTURE 2). Adjust the fertilizer side bottom flap to position 1.

Before beginning the fertilizer side calibration test, remove the locking pin of the seed side shaft and turn the adjustment handle to position 0 (PICTURE 1). This way the feeder shaft will not rotate during the calibration test, and the seeds in the tank will not flow out.

To adjust the amount of fertilizer you spread, turn the adjustment wheel on the left end plate of the machine. (PICTURE 2)

Select the values (PICTURE 3) from the main scale on the adjustment wheel lock and the circular scale on the adjustment wheel. The groove that runs on the circumference of the wheel indicates the adjustment wheel's position in relation to the main scale. Guideline values for adjusting the feeding devices are in the sowing table. In the fertilizer table, the amounts to be spread per hectare are given in the vertical column and the feeding device settings in the horizontal scale. The lower, larger numbers signify the main scale values and the upper, smaller numbers the circular scale values (PICTURE 3).

The sowing table can be found on the end of the machine and in this manual (PAGE 28). Choose the correct line of the two lines in the sowing table, i.e. will the fertilizer be spread through 24 or 12 coulters. The intersection point of the desired spreading amount and the line will show the correct feeding device settings in the horizontal scale.

For example, when spreading fertilizer 400 kg/ha through 24 coulters, the setting is 3.6. The adjustment wheel must be turned so that the groove on the rim of the wheel is position 3 of the scale. The wheel needs to be rotated long enough to place notch 6 in the circular scale under the lock in the main scale (PICTURE 3).

It is recommended that you always perform the calibration test before choosing the final amounts to be spread. The type of the fertilizer, its specific weight and, for example, its moisture affect how easily the fertilizer flows in the feeding mechanism.

Do the calibration test by rotating the feeding mechanism using the calibration test crank at the end of the shaft coming from the ground wheel. (PICTURE 2). Amounts of rotations per are (100m<sup>2</sup>) are shown on the sticker (PICTURE 4) attached to the machine at the location where the round test is done. The Maestro has one roller chain, which is used to transmit power from the ground wheel to the drive shaft that runs through the machine to the gearbox. The chain can be installed on two different pairs of chain wheels (PICTURES 5 and 6).

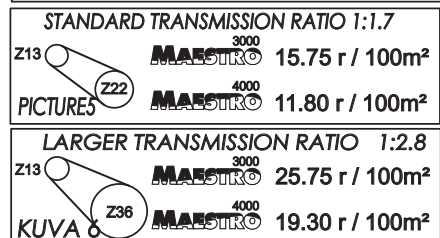
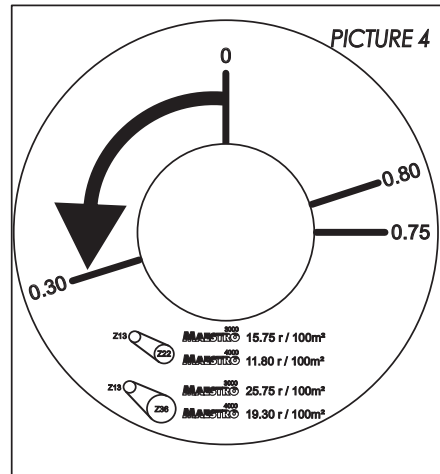
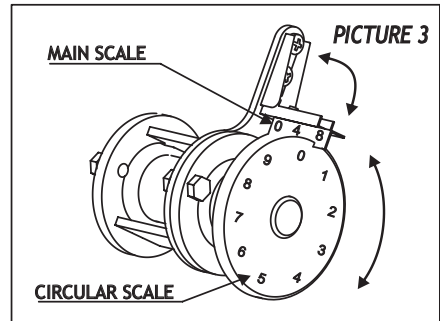
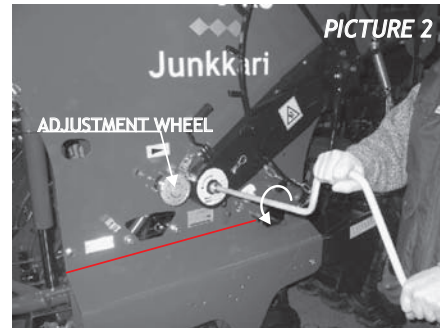
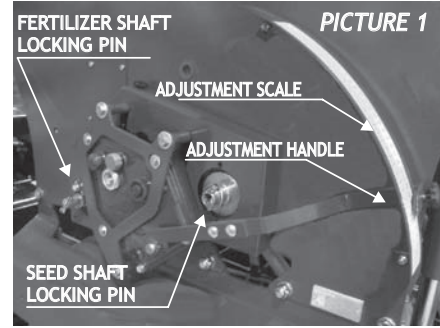



The standard installation matches picture 5, which means that the sowing table on page 28 must be used. If the transmission ratio has been changed to match picture 6, use the table on page 29.



When you need to spread more fertilizer than 500 kg/ha through 12 coulters, you must use the larger transmission ratio.

Push the calibration tray under the fertilizer side feeder cases as shown in picture 7. There is a matching hole for another tray at the other end of the tank.

Do the calibration test for an area of 100 m<sup>2</sup> and multiply the weighing results by a hundred to reach the amount for a 10 000 m<sup>2</sup>, in other words 1 ha area.

If the result does not match the guideline value in the calibration test table, make an adjustment using the adjustment wheel. Always adjust from smaller values to larger ones. This way the possible adjustment clearance of the adjustment wheel screw is eliminated.

During the calibration test, you can move the feed hoppers from under the feeder cases using the locking handle. Push the fertilizer side feed hoppers backwards so the fertilizer can flow into the calibration test troughs (PICTURE 8).

Keep the locking handle locked in its fasteners in sowing position.

If separate fertilizer coulters are used, the feed hoppers need to be pulled forward to make way for the calibration test troughs (PICTURE 9).

The calibration trays are kept on the right side of the machine, between the roller wheels and the tank (PICTURE 10).

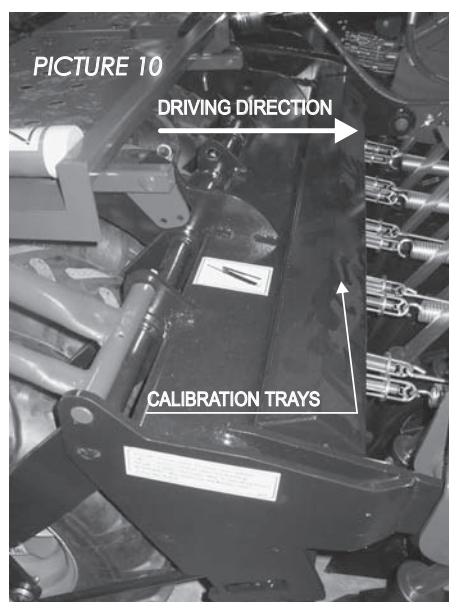
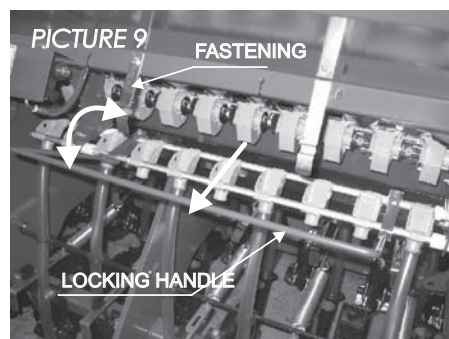
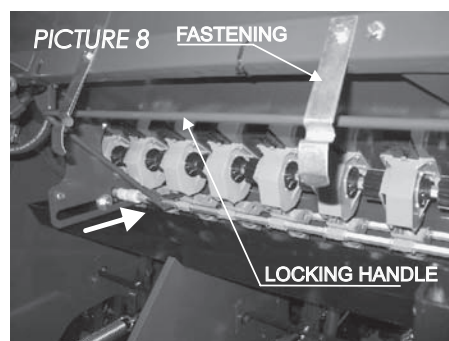
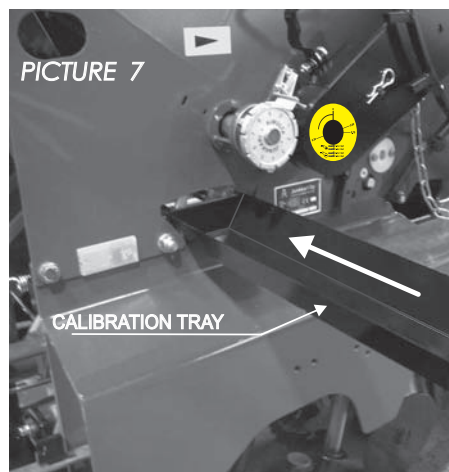

$a = 100\text{m}^2$ $ha = 10\,000\text{m}^2$
--

FERTILIZER SIDE SOWING TABLE FOR THE CHAIN WHEEL PAIR Z13/Z22 i=1:1.7

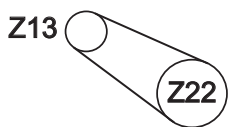
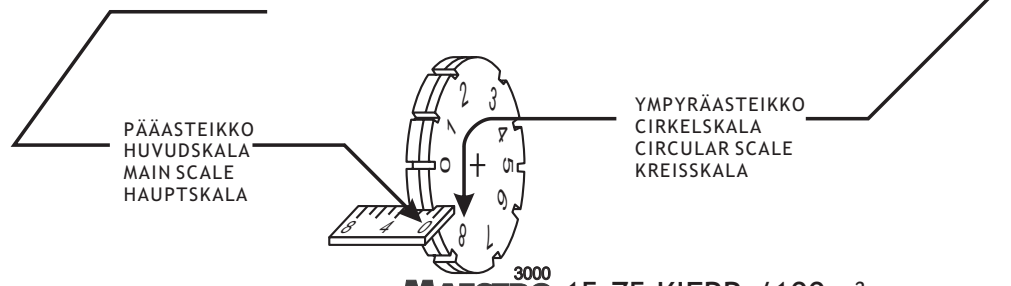
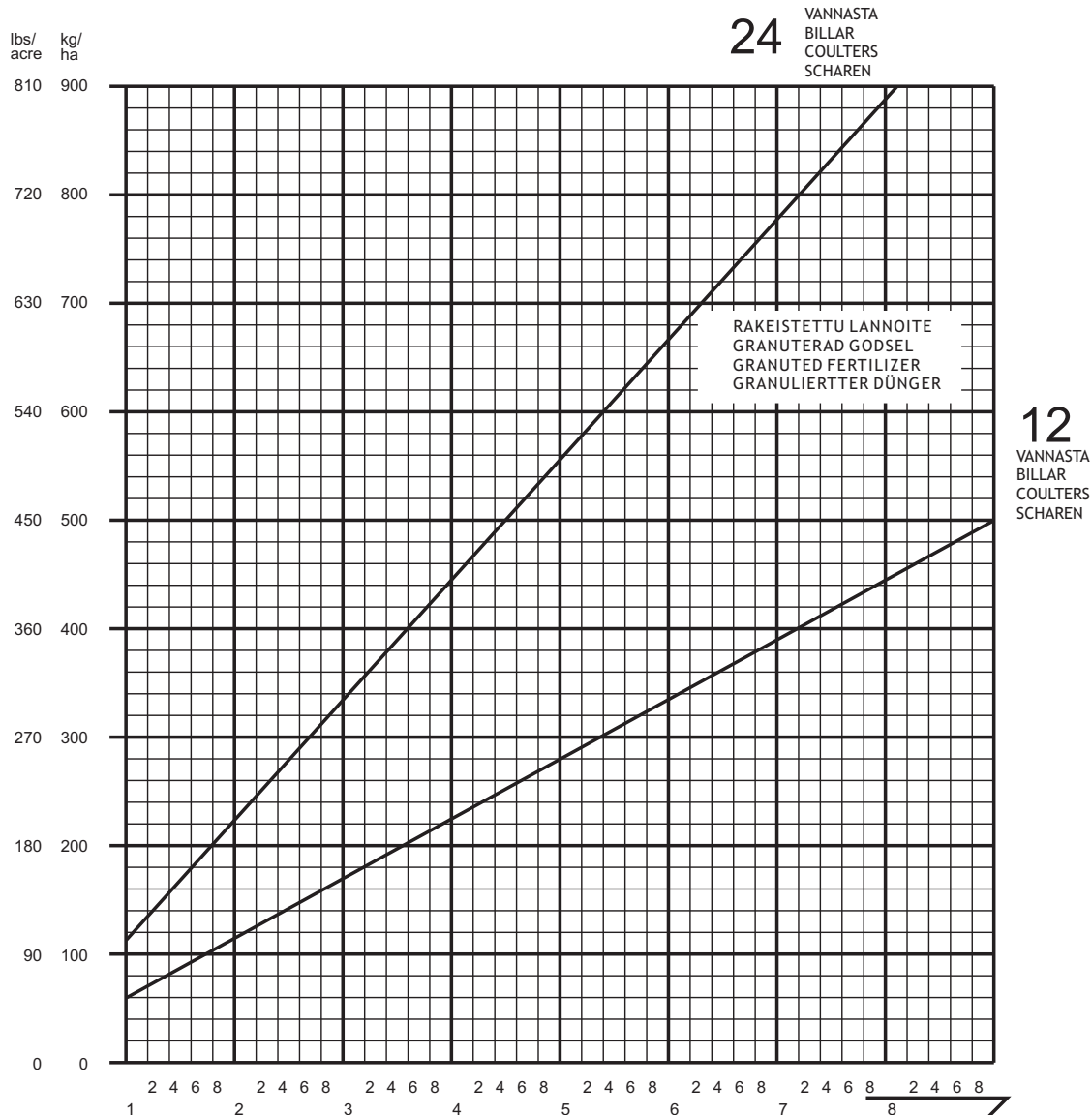

**MAESTRO**<sup>3000</sup> 15,75 KIERR. / 100m<sup>2</sup>  
 ROTATIONS / 100m<sup>2</sup>  
 UMDR. / 100m<sup>2</sup>

**MAESTRO**<sup>4000</sup> 11.80 KIERR. / 100m<sup>2</sup>  
 ROTATIONS / 100m<sup>2</sup>  
 UMDR. / 100m<sup>2</sup>



FERTILIZER SIDE SOWING TABLE FOR THE CHAIN WHEEL PAIR Z13/Z36 i=1:2.8

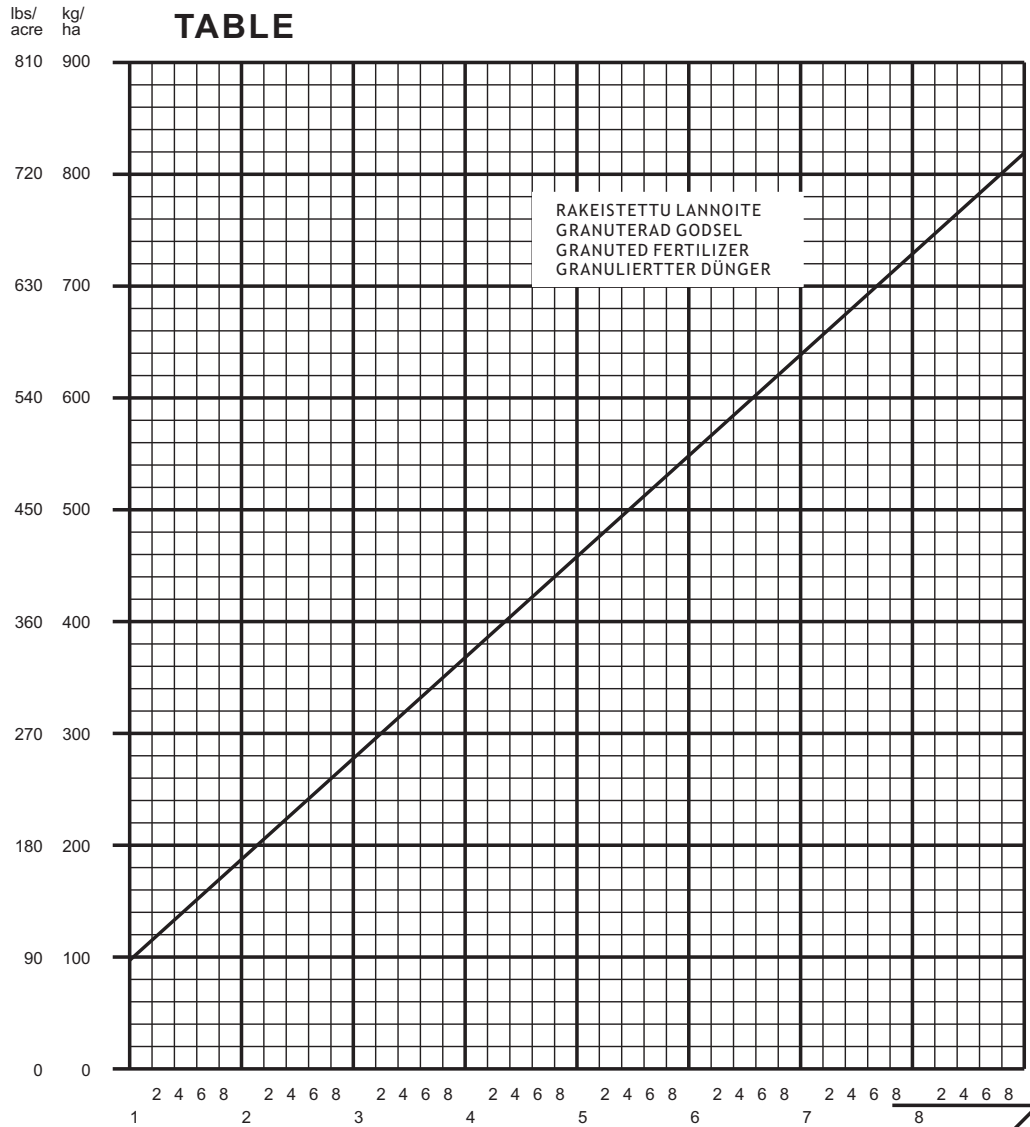

**12**  
VANNASTA  
BILLAR  
COULTERS  
SCHAREN

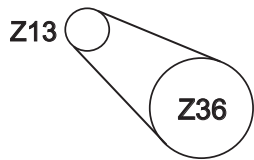
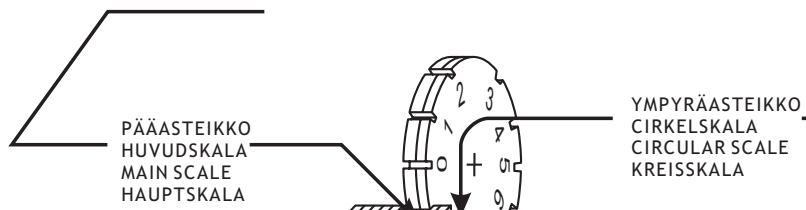

**MAESTRO**<sup>3000</sup> 25,75 KIERR./100m<sup>2</sup>  
ROTATIONS/100m<sup>2</sup>  
UMDR./100m<sup>2</sup>

**MAESTRO**<sup>4000</sup> 19,30 KIERR./100m<sup>2</sup>  
ROTATIONS/100m<sup>2</sup>  
UMDR./100m<sup>2</sup>



### 12.2.2 SEED SIDE

Do the calibration test with the machine raised and the ground wheel in transport position (PICTURE 5). Adjust both of the seed side bottom flaps (located at both ends of the machine) to suit the seed type (PICTURES 1 and 2).

Before beginning the seed side calibration test, remove the locking pin of the seed side shaft (PICTURE 4). This way the feeder shaft will not rotate during the calibration test, and the seeds in the tank will not flow out. In addition, adjust the small flap to position 2 (PICTURE 3) and push the calibration trays in their places (PICTURE 9).

Choose the amount to be sowed (kg/ha) by moving the adjustment handle (PICTURE 4) to the desired position of the adjustment scale. The amounts matching the scale values are in the sowing table on page 32. The horizontal axis of the table shows the adjustment scale values and the vertical axis the amounts to be sown (kg/ha).

It is recommended that you perform the calibration test before choosing the final amounts to be sown. The cleanliness of the seed, its specific weight and, for instance, the bating affect how easily the seeds flow in the feeding mechanism.

Do the calibration test by rotating the feeding mechanism with the calibration test crank at the end of the shaft, that comes from the ground wheel. (PICTURE 5). Amounts of rotations per are (100m<sup>2</sup>) are shown on the sticker (PICTURE 6) attached to the machine to the spot where the test is done.

The Maestro has one roller chain, which is used to transmit power from the ground wheel to the drive shaft that runs through the machine to the gearbox. The chain can be installed on two different pairs of chain wheels (PICTURES 7 and 8). The standard installation matches picture 7.

Keep the bottom hatches (PICTURE 2) completely open for all seed types. The bottom hatch can, in some special cases, be used to make the opening between the tank and the feeder case smaller or to close it entirely.

After sowing the easiest way to empty the machine is to push the adjustment handle of the bottomflap as far frontwards as you can.

POHJALÄPÄN ASENNOT **PICTURE 1**  
 BOTTENKLAFFENS LÄGE  
 POSITION OF THE BOTTOMFLAP  
 BODENKLAPPENSTELLUNG

0	1	2
Piensiemen	Vilja	Herne
Småfrö	Spannmål	Ärter
Small seed	Grain seeds	Peas
Kleinsamen	Getreide	Erbsen

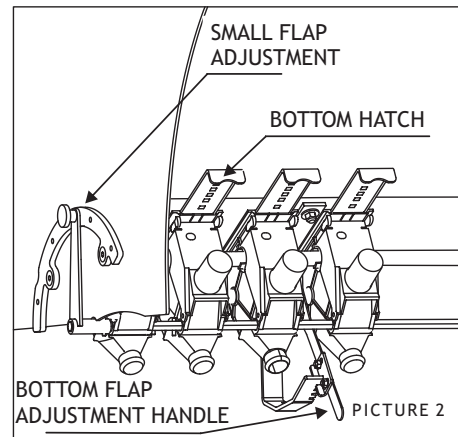

**SMALL FLAP POSITIONS**

1. EMPTYING THE MACHINE
2. CALIBRATION TEST
3. NORMAL SOWING / SMALL SEED TO THE SURFACE
4. START FERTILIZER SOWING

**PICTURE 3**

POHJALÄPÄN ASENNOT  
 BOTTENKLAFFENS LÄGE  
 POSITION OF THE BOTTOMFLAP  
 BODENKLAPPENSTELLUNG

0	1	2
Piensiemen	Vilja	Herne
Småfrö	Spannmål	Ärter
Small seed	Grain seeds	Peas
Kleinsamen	Getreide	Erbsen

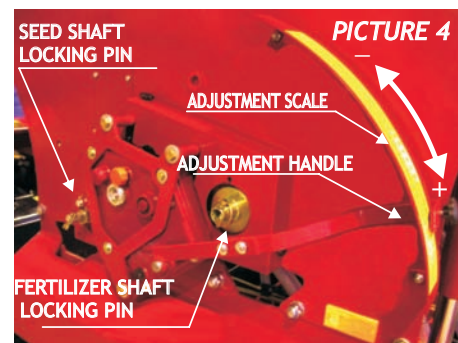

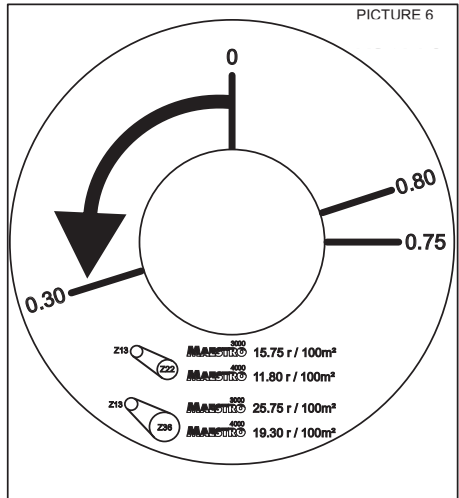

A sticker can be found at the place where the calibration test is done (PICTURE 6). The sticker shows the calibration test rotation for different machine models and transmission ratios. It also shows the positions where you start and finish the rotation.

The standard installation matches picture 7.



STANDARD TRANSMISSION RATIO		1:1.7
Z13	MAESTRO 3000	15.75 r / 100m <sup>2</sup>
PIC 7	MAESTRO 4000	11.80 r / 100m <sup>2</sup>

LARGER TRANSMISSION RATIO		1:2.8
Z13	MAESTRO 3000	25.75 r / 100m <sup>2</sup>
PIC 8	MAESTRO 4000	19.30 r / 100m <sup>2</sup>

Weigh the amount of seed or fertilizer that has flown into the calibration trays and multiply the result by a hundred. The end result is the amount in kilograms that the machine will sow with the current setting.

$$a = 100\text{m}^2$$

$$ha = 10\,000\text{m}^2$$

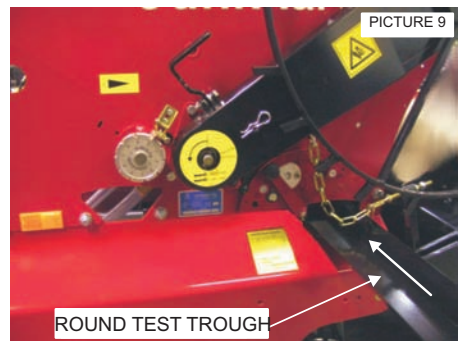

SEED SIDE SOWING TABLE FOR THE STANDARD CHAIN WHEEL PAIR Z13/Z22 i=1:1.7

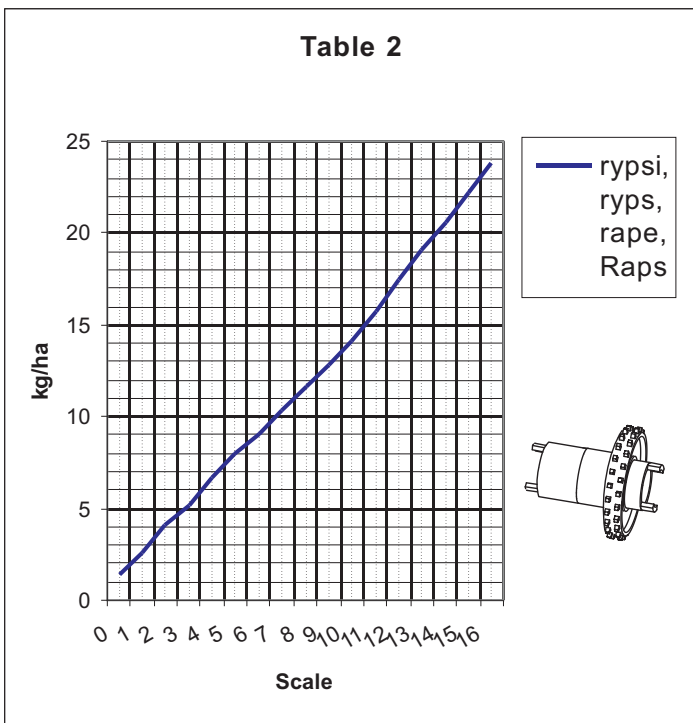
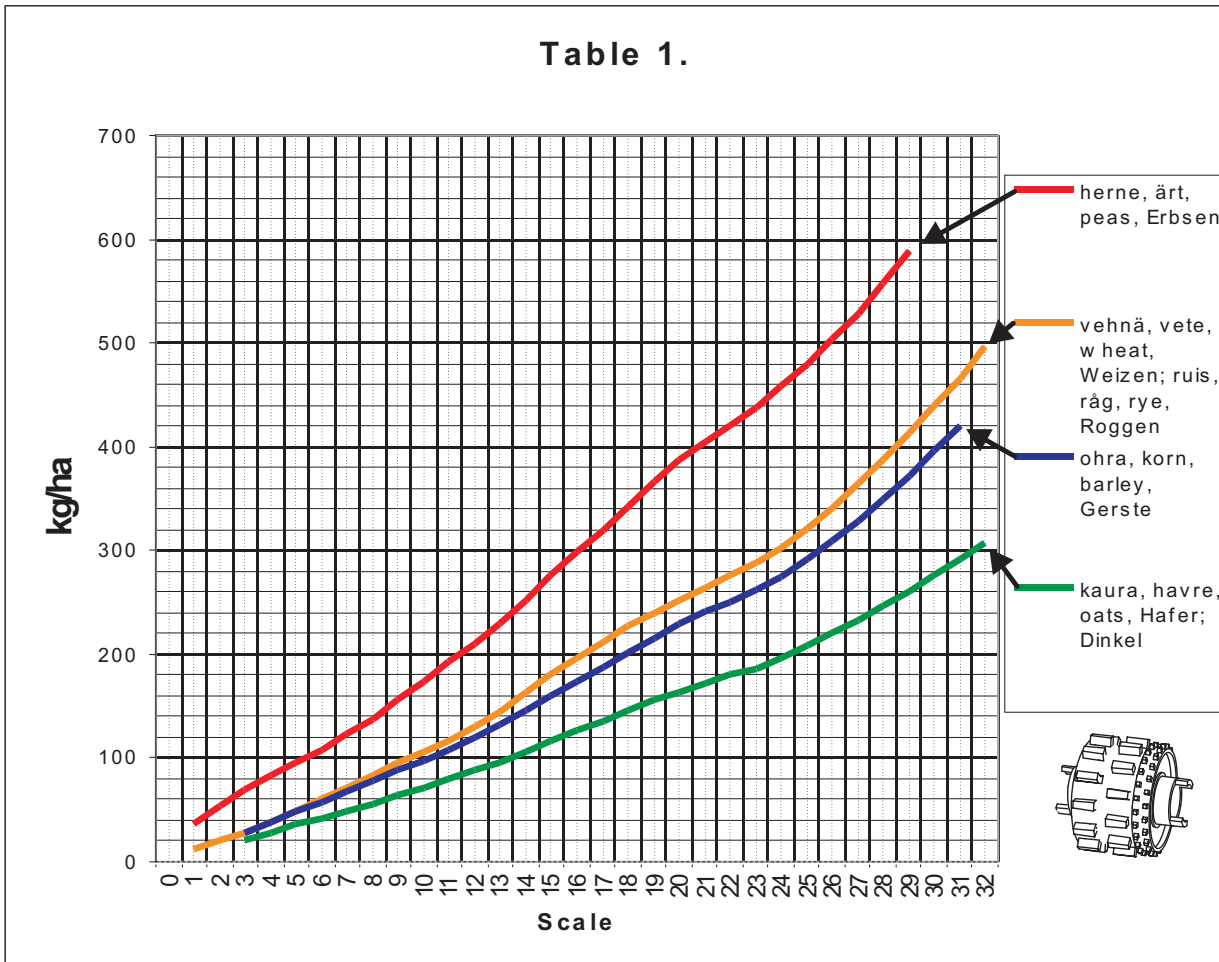

POHJALÄPÄN ASENNOT  
 BOTTENKLÄFFENS LÄGE  
 POSITION OF THE BOTTOMFLAP  
 BODENKLAPPENSTELLUNG

0	1	2
Piensiemen	Vilja	Herne
Småfrö	Spannmål	Ärter
Small seed	Grain seeds	Peas
Kleinsamen	Getreide	Erbsen

**MAESTRO** <sup>3000</sup> 15,75 KIERR/100m<sup>2</sup>  
 ROTATIONS/100m<sup>2</sup>  
 UMDR. /100m<sup>2</sup>

**MAESTRO** <sup>4000</sup> 11,80 KIERR/100m<sup>2</sup>  
 ROTATIONS/100m<sup>2</sup>  
 UMDR. /100m<sup>2</sup>

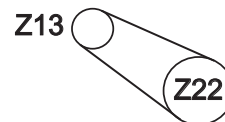

FERTILIZER SIDE SOWING TABLE FOR THE CHAIN WHEEL PAIR Z13/Z36 i=1:2.8

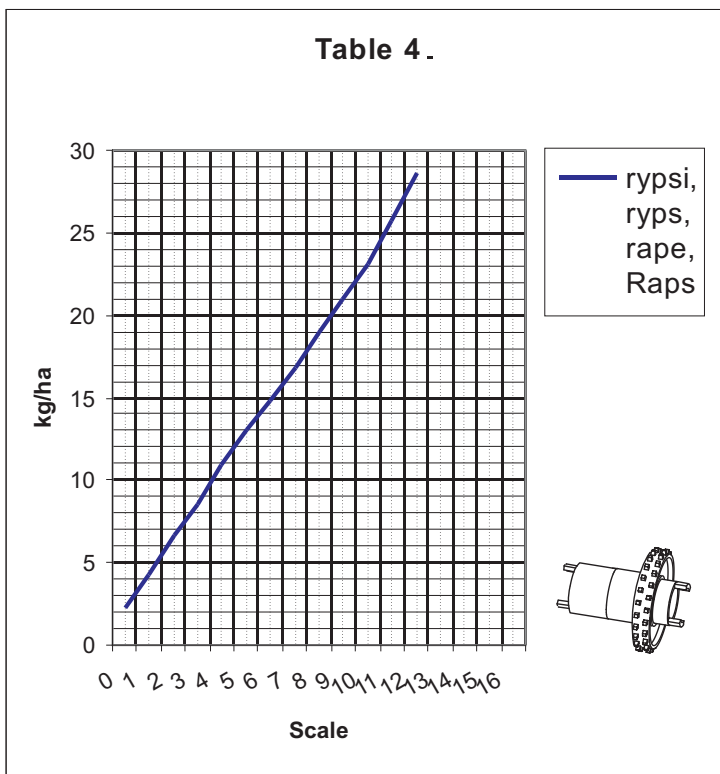
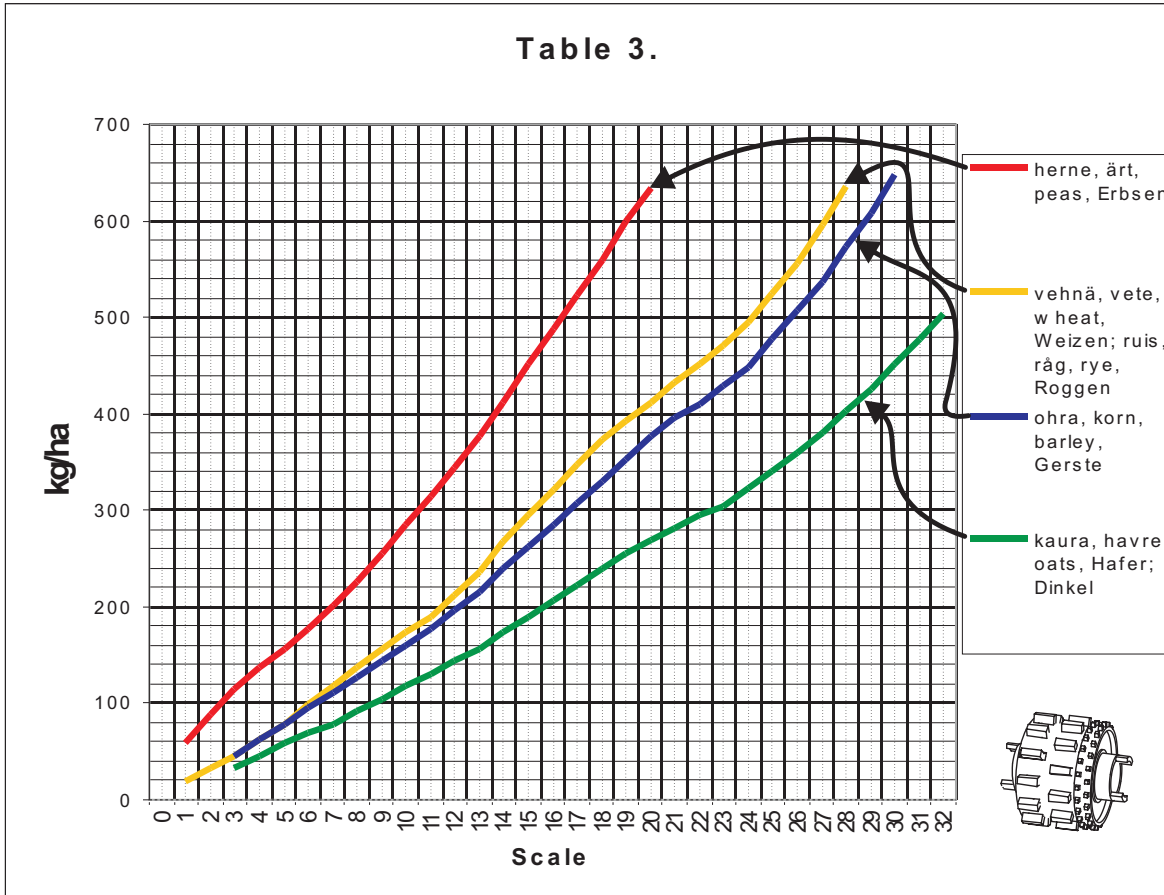

POHJALÄPÄN ASENNOT  
 BOTTENKLAFFENS LÄGE  
 POSITION OF THE BOTTOMFLAP  
 BODENKLAPPENSTELLUNG

0	1	2
Piensiemen	Vilja	Herne
Småfrö	Spannmål	Ärtor
Small seed	Grain seeds	Peas
Kleinsamen	Getreide	Erbsen

**MAESTRO**<sup>3000</sup> 25,75 KIERR/100m<sup>2</sup>  
 ROTATIONS/100m<sup>2</sup>  
 UMDR./100m<sup>2</sup>

**MAESTRO**<sup>4000</sup> 19,30 KIERR/100m<sup>2</sup>  
 ROTATIONS/100m<sup>2</sup>  
 UMDR./100m<sup>2</sup>

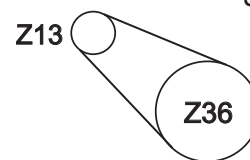

## Calibration test

---

An example of a calibration test:

You wish to sow oats 210 kg/ha and spread fertilizer 400 kg/ha.

### SEED:

1. Fill the tank with at least 100 kg of seeds.
2. Raise the machine and make sure the ground wheel is in transport position.
3. Adjust the positions of the bottom flaps according to the seed type.
4. Remove the locking pin of the fertilizer shaft chain wheel.
5. Check the sowing table for the value corresponding to the amount of oats (210 kg/ha) to be sown. In this case, the value is 25.
6. Move the gearbox adjustment lever to scale position 25.
7. Push the calibration trays under the metering devices.
8. Spin the test crank a few rounds and check that all the feeding houses are feeding. Pour the seeds from the trays back to the tank and reinstall the trays.
9. Rotate the crank with the speed of 1 rotation per second. Test rotations (see table).
10. Weigh the seeds that are now in the trays and multiply the weight by a hundred.
11. If the result of the weighing differs considerably from the value given in the sowing table, readjust the machine and run the test again.

### FERTILIZER:

1. Fill the tank with at least 100 kg of fertilizer.
2. Raise the machine and make sure that the ground wheel is in transport position.
3. Adjust the bottom flap to position 1.
4. Remove the locking pin of the seed shaft chain wheel and move the adjustment lever to position 0.
5. Check the value corresponding to fertilizer amount (400 kg/ha) from the table line that matches the amount of coulters used (in this case, it is the 24 coulter line). The table will give you the setting: main scale value 3 and circular scale value 6.
6. Adjust the feed from the adjustment wheel on the right side of the machine so that the main scale value, which is read from the adjustment wheel centre, is 3. Rotate the adjustment wheel six more notches so that the circular scale value is 6. Always adjust from a smaller value to a larger one.
7. Push the calibration trays under the metering devices.
8. Spin the test crank a few rounds and check that all the feeding houses are feeding. Pour the fertilizer from the trays back into the tank and reinstall the trays.
9. Rotate the crank with the speed of 1 rotation per second. Test rotations (see table).
10. Weigh the fertilizer that is now in the trays and multiply the weight by a hundred.
11. If the result of the weighing differs considerably from the value given in the sowing table, readjust the machine and run the test again.

NOTE THAT, BECAUSE SEEDS AND FERTILIZERS DIFFER IN COMPOSITION AND MOISTURE, ETC., THE VALUES IN THE SOWING TABLE ARE MEANT AS GUIDELINES ONLY.

To avoid the danger of getting squeezed between the parts, the seed and fertilizer drill must be in the raised position when lowering the ground wheel.



The ground wheel can be lowered as shown in picture 1, when the machine is in the raised position. Grab the pull-out handle with your left and the lifting handle with your right hand. Use the pull-out handle to turn the ground wheel outward while supporting and carefully lowering it with the lifting handle.



## 12.3 DOING A DRIVING TEST

The most accurate results can be achieved when the calibration test is done by driving. The driving test takes into account changes in the feed due to, for example, slipping of the ground wheel and machine vibration.

A driving test for the seed side can be done as follows:

1. Release the fertilizer feed.
2. Prepare the machine as described in the test instructions.
3. Lower the ground wheel to the working position as shown in picture 1.
4. Measure a distance that equals a 100 m<sup>2</sup> sowing area, i.e. the specific distance for each machine type.

Driving distances per are with different working widths:

Maestro 3000 33.3 m  
Maestro 4000 25 m

5. Drive approximately 10 metres outside the test distance to ensure that every metering device is feeding.
6. Empty the contents of the trays back into the tanks.
7. After this, drive the measured distance with the machine lowered to the working position.
8. Measure the amount in the trays and multiply it with 100 to get the seed amount (kg/ha).
9. If adjustments are necessary, follow the instructions given in the calibration test section.
10. After performing the field test, remember to switch the fertilizer feed back on, remove the trays and turn all levers to sowing position.

## 12.4 HOPPER CAPACITIES AND ADJUSTMENT OF THE PARTITION WALL

Maestro seed and fertilizer drills are equipped with an adjustable partition wall between the fertilizer and seed hoppers. See table below for the possible adjustment ratios.

The wall can be moved to eight positions, 1-7 and S.

In the S position, the tank is used solely as a seed tank.

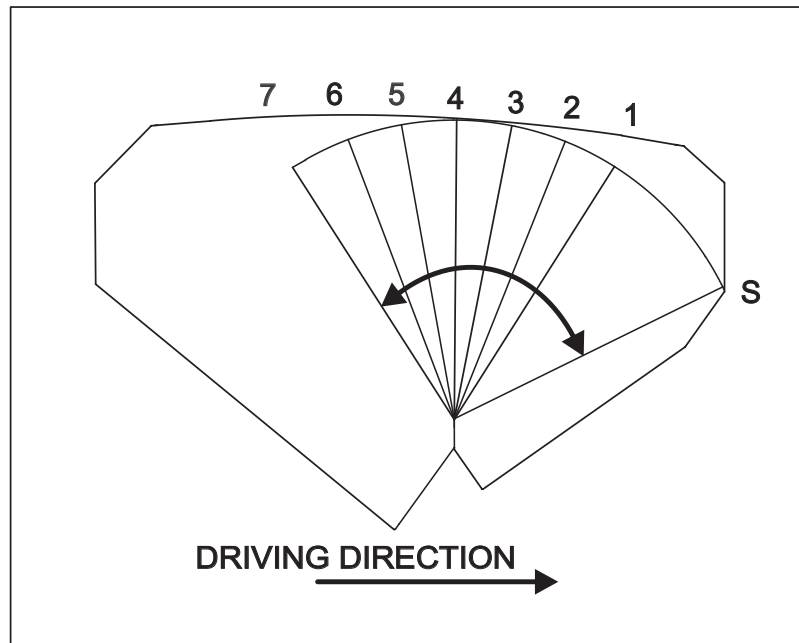

Maestro 3000		
Position	Volume, seed / l	Volume, fertilizer / l
1	2469	773
2	2396	934
3	2340	1096
4	2179	1255
5	1982	1419
6	1784	1580
7	1545	1760
S	3323	—

Maestro 4000		
Position	Volume, seed / l	Volume, fertilizer / l
1	3370	1055
2	3271	1275
3	3194	1496
4	2973	1713
5	2705	1936
6	2435	2156
7	2108	2402
S	4535	—



## 12.5 SOWING

It is recommended to perform a test run with a new seed and fertilizer drill - in other words, drive the machine without seeds or fertilizer. This is important, because during the test run the operator will get to know the controls and structure of the machine well before the busy sowing season.

### SOWING TIME

The correct sowing time has a great effect on the outcome of the sowing. The time should be determined based mainly on moisture conditions, the importance of which varies between different soil qualities.

The seeds should be sown in the ground in a way that they will constantly receive moisture, but he moisture must not be too excessive. As a general rule, if the soil sticks to the tires of the machine, you should choose another time for sowing.

The temperature of the soil is another factor you should take into account when determining the sowing time. If you sow in cold soil, the seeds take long to sprout and some of them may not germinate at all. Avoid sowing on frozen ground.

If you do not have enough personal experience to determine the right sowing time, you should consult an expert.

### FERTILIZATION

Fertilization means providing a plant with nutrients, and its need can be best determined through a soil fertility survey. The amount of fertilizer a plant needs is usually calculated based on the amount of nitrogen. Out of fertilizers that have the same amount of nitrogen the most suitable one is the one that has other nutrients a plant requires, such as trace elements. If the amount of some nutrient in the chosen fertilizer exceeds or comes short of the plants' needs, the following year you can choose a fertilizer, which diverts from the desired levels in the opposite direction. Representatives of fertilizer manufacturers can help you with choosing the correct amounts of fertilizer, if necessary.

### SEED

Each plant has a specific growing density, with which it produces the best crop. An excessively small amount of seeds will not yield the best crop and may cause secondary shoots. An excessively large amount of seeds, on the other hand, is unnecessary, uneconomical and increases the amount of flattened corn.

The amount of seeds per area unit must be calculated according to the condition, germinability and purpose of the seed as well as the circumstances.

Grass is usually sown among protective corn. The best protective corns are early, strong and short stemmed species, especially barley. To ensure that the protective plant hinders the sprouting of the grass as little as possible, the feed amounts must be reduced by 20-40 %.

The correct amounts of seeds should always be checked from the seed vendor or other experts.

It is recommended that you choose a sowing depth that is as shallow as possible to make seeds sprout quickly. Always ensure, however, that the seeds get enough moisture under all circumstances. You should be especially careful about sowing too close to the surface in easily drying soil, since the moisture on the surface will evaporate and the seed will be left in dry soil. In locations where there is not enough moisture during the spring, the seed needs to be sowed sufficiently deep, even though that may prolong sprouting.

When sowing with a standard Junkkari Maestro drill, the fertilizer and seeds go into the same furrow.

The machine can also be equipped with separate fertilizer coulters. This way the fertilizer and seed will go into different rows. In this case, row spacing will be 12.5 cm for the seeds and 25 cm for the fertilizer.

#### PLANT PROTECTION SPRAYING

The spraying can be done either before or after the sowing. In the autumn, however, the spraying should be done before the sowing. Note that there must be a period of three days between the spraying and the sowing.

As a general rule, do not break the weeds and spray only when the weeds have sprouted enough (their leaves are large enough). If you are unsure of the proper procedure, contact an expert.

Always check sowing depths in the field, since, due to differences in soil quality and tilling methods etc., no universally applicable tables or measurements are available.

## 12.6 USER MANUAL FOR THE SEED DRILL CONTROLLER



### WIZARD CONTROLLER FOR THE JUNKKARI MAESTRO SEED AND FERTILIZER DRILL



Junkkari Oy  
62375 YLIHÄRMÄ FINLAND  
TEL. +358-(0)6-4835111  
Fax +358-(0)6-4843295  
e-mail: junkkari@msk.fi  
Internet: www.junkkari.fi

ENGLISH 2009 

Electro - Magnetic Compatibility (EMC)

# 1 CONTENTS

2.	BASIC SETTINGS .....	35
3.	SUMMARY OF THE FUNCTIONS .....	36
4.	SPEED/SENSOR CALIBRATION .....	37
5.	SURFACE AREA/WORKING WIDTH .....	39
6.	TRAM LINE MARKING .....	41
	6.1 SYMMETRICAL TRAM LINE MARKING .....	42
	6.2 ASYMMETRICAL TRAM LINE MARKING ON THE LEFT.....	43
	6.3 ASYMMETRICAL TRAM LINE MARKING ON THE RIGHT.....	44
	6.4 TRAM LINE MARKING FOR THE 18 METRE SYSTEM .....	45
	6.5 PROGRAMMING THE RHYTHM OF THE TRAM LINE MARKING.....	47
7.	FERTILIZER SHAFT MONITORING/ALARM .....	48
8.	SEED SHAFT MONITORING/ALARM .....	49
9.	MACHINERY GUARD.....	50
10.	TANK LEVEL GUARD .....	51
11.	ROW MARKING.....	52

The on-board computer in Junkkari seed and fertilizer drills is equipped with a lit 4-digit display with the following functions:

- Surface area measurement (total area and distance)
- Speed km/h
- Tram line marking (symmetrical and asymmetrical)
- Monitoring the rotation of the seed shaft and fertilizer shaft
- Tank guard
- Machinery guard

The on-board computer has two memory registers, which store the partial and total surface areas that are worked on.

The data is stored automatically when the monitor is turned off. Tram line marking is the default function for normal operation unless the surface area function has been chosen or the alarm is active.

The on-board computer's calibration is a condition for monitoring the adapting of the equipment. If necessary, the default settings can be changed in the programming functions.

The on-board computer can also be used to control the hydraulic row markers.

## BASIC SETTINGS

The Wizard monitor has three types of basic settings:

The built-in basic settings of the Wizard computer (first basic setting):

- When the monitor is reset (software update), it reverts back to the defaults of these values.

The values programmed at Junkkari (second basic setting):

- Programmed by the manufacturer.
- At Junkkari the values are changed to suit the MAESTRO specifically.

The values programmed by the user (third basic setting)

**The basic settings, that are programmable by the user:**

Press and hold **+1** for three (3) seconds on the function you have chosen. Set the value with the  button

Function	Programmable factor	Basic setting (Wizard)	Basic setting	Basic setting (user)
1. Km/h	Tire circumference*	2.000 m	n 2.050	-----
2. Ha	Working width	2.000 m	machine width	-----
3. Tram line	Tram line marking	Sy.04	Sy/Al/Ar/18m/OFF	-----
4. F. shaft speed	Low speed alarm	0.000rpm	0.01 with switch/ 0.00 without switch.	-----
5. S. shaft speed	Low speed alarm	0.000rpm	0.01 with switch/ 0.00 without switch.	-----
6. Tank fullness	Tank guard on/off	1	1=ON	-----

\* press **+1** and  to start automatic tire calibration. Press  after 100m.

The built-in basic settings of the Wizard computer:

Turn the power on by holding down **+1**. Choose function with the button **+1**. Set value with the button .

Function	Programmable factor	Basic setting (Wizard)	Basic setting	Basic setting (user)
1. Km/h	No function	-	-	-----
2. Ha	Total surface area (not programmable)	-	-	-----
3. Tram line	Counter	1	1=ON/0=OFF	-----
4. F. shaft speed	Speed pulses/round	8.000	12 with switch/ 0 without switch.	-----
5. S. shaft speed	Speed pulses/round	8.000	12 with switch/ 0 without switch.	-----
6. Machinery guard	Allowed deviation %	25 %	25	-----

### 3 SUMMARY OF THE FUNCTIONS

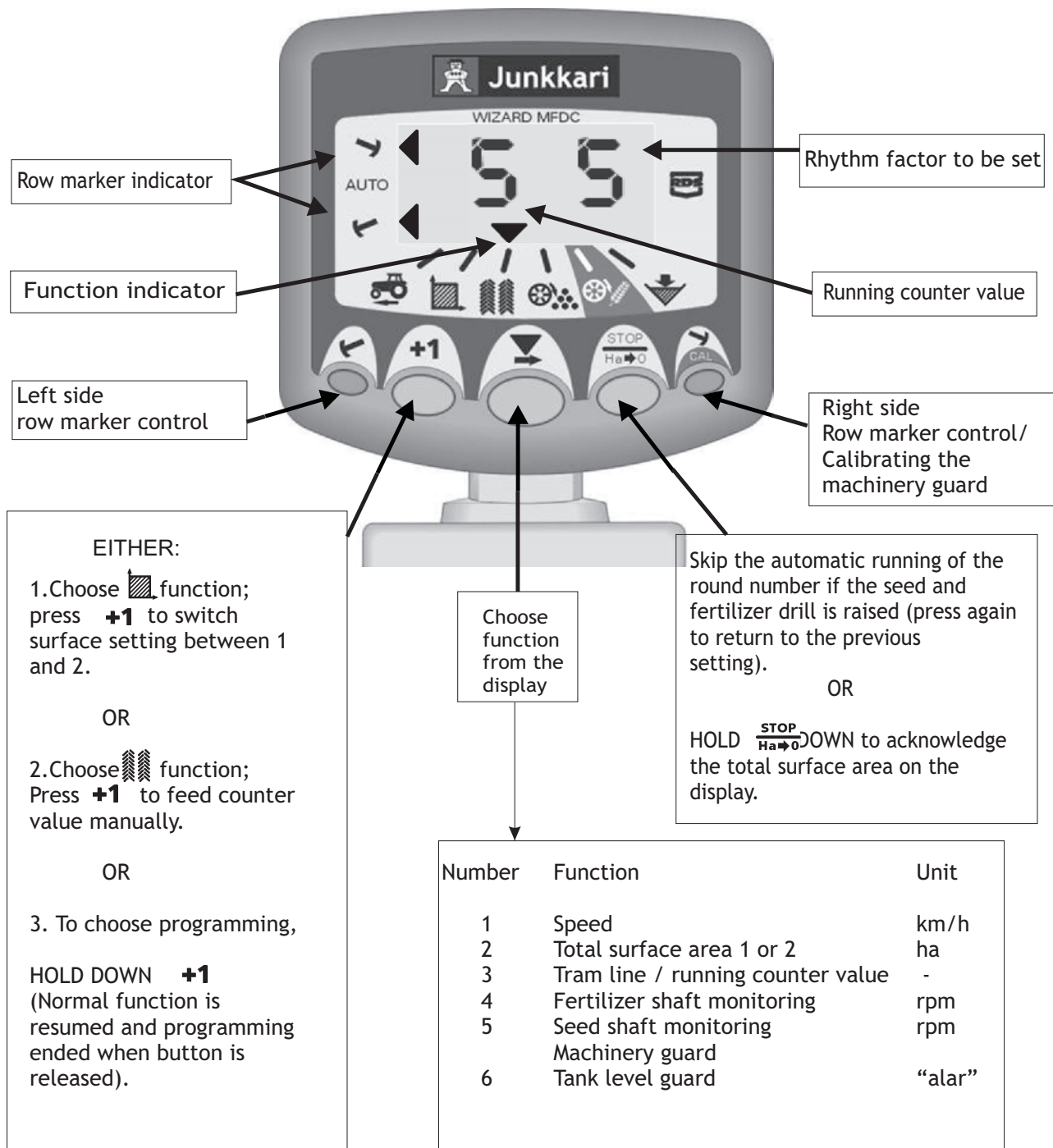



## 4 SPEED/SENSOR CALIBRATION

### 1. CHOOSING THE SPEED FUNCTION



If your speed is lower than 2 km/h, the monitor beeps twice and starts alternating between the chosen function and the speed function.

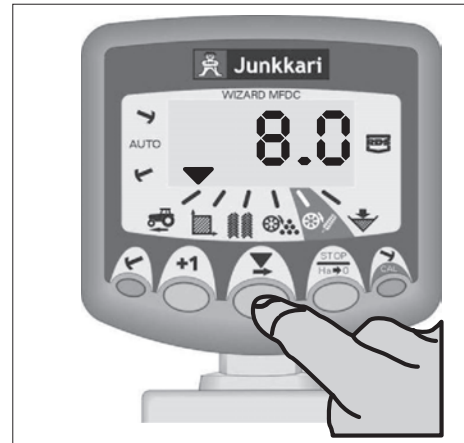

### 2. CALIBRATING THE SPEED SENSOR MANUALLY

In the Simulta seed and fertilizer drill, the speed sensor is located at the end of the fertilizer shaft, in the machinery. The theoretical calibration number equals the circumference of the rotating wheel (diameter x 3,142) in metres x the transmission ratio.

The average default value is **2.050**.

The automatic calibration is more accurate in field conditions.

Choose  function and release.

HOLD **+1** DOWN and ...

Press  to choose digit or decimal.

 2.000,  2.000,  2.000,  2.000, etc

Hold  down and change the value or the location of the decimal.

 2.100,  2.200,  2.300,  2.400, etc

To choose the next digit, release  and repeat the procedure, if necessary.

When you release **+1** the programming will end and the values you input will be stored in the device's memory.

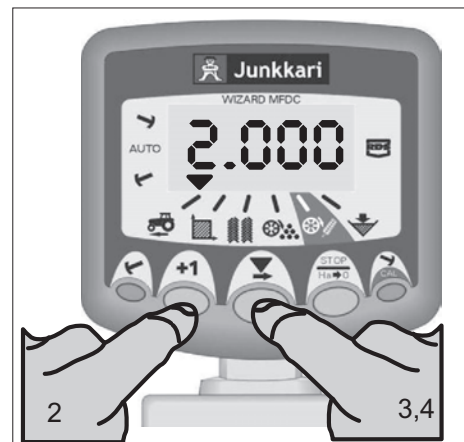
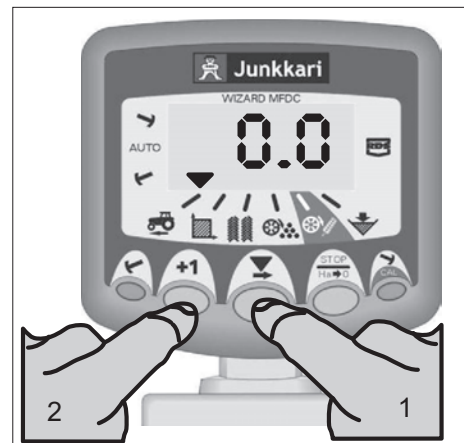

### 3. AUTOMATIC SPEED CALIBRATION

Using automatic speed calibration will achieve maximum accuracy in field conditions.

Place marks at 100 m intervals and drive the vehicle to the first mark with the front of the vehicle facing the mark.

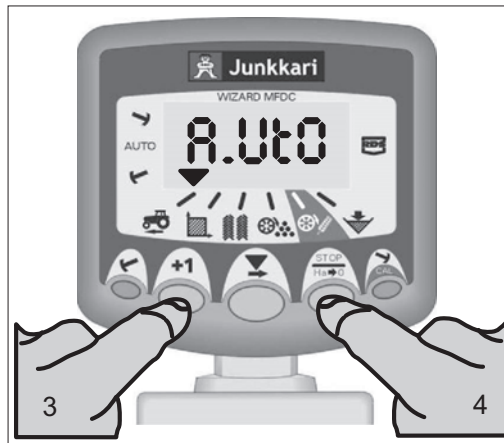

Choose  function.

HOLD **+1** DOWN.  
The monitor will start the programming function in three seconds.

Press  $\frac{\text{STOP}}{\text{Ha} \rightarrow 0}$   
Automatic calibration will begin.

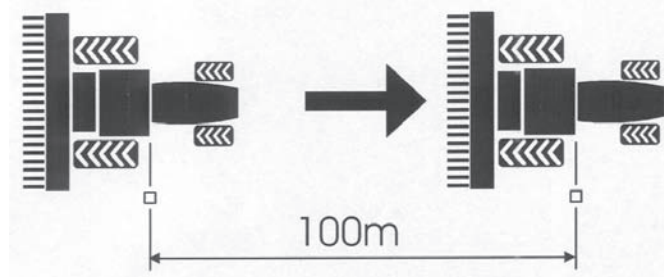

Drive to the next mark. The monitor will show the number of pulses the pulse sensor received during the distance as an integer.

Press  $\frac{\text{STOP}}{\text{Ha} \rightarrow 0}$   
Speed calibration is complete.  
The calibration factor has been automatically calculated and stored in the memory.

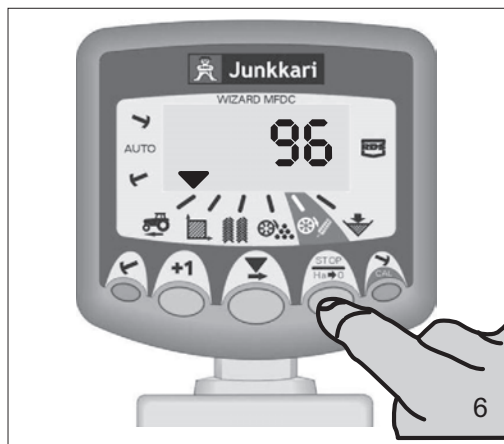

## 5 SURFACE AREA/WORKING WIDTH

### 1. CHOOSE SURFACE AREA FUNCTION



The on-board computer has two surface area registers. Each of them can be reset separately.

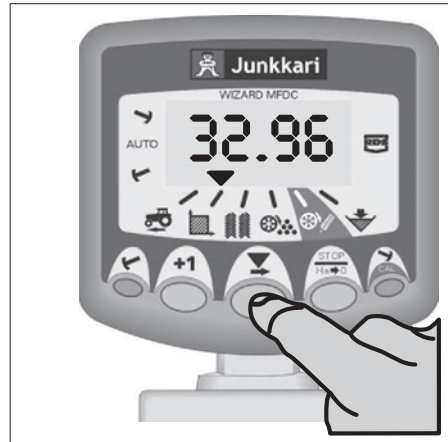

### 2. CHOOSING THE SURFACE AREA REGISTER

Press **+1** to switch between the two registers, TOT1 or TOT2.

You can accumulate two different surface areas alternatively.

The display will show the area accumulated after the last reset.

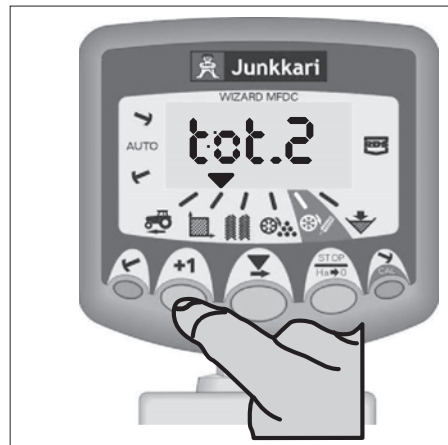

### 3. RESETTING THE SURFACE AREA REGISTER

Choose TOT1 or TOT2 and release.

HOLD **STOP** button for 5 seconds.



The number will reset to zero.

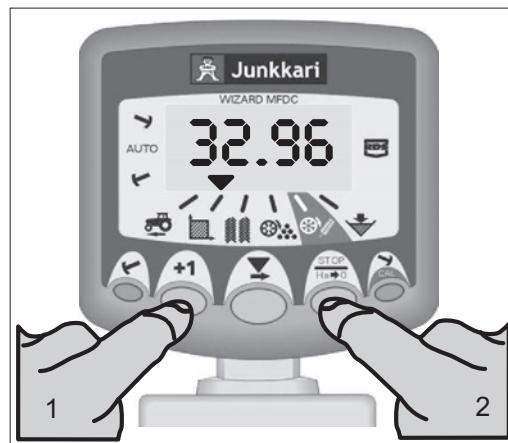

#### 4. PROGRAMMING THE WORKING WIDTH

The working width of the machine in metres.

Choose  function.

HOLD **+1** DOWN.  
The monitor will start the programming function in three seconds.

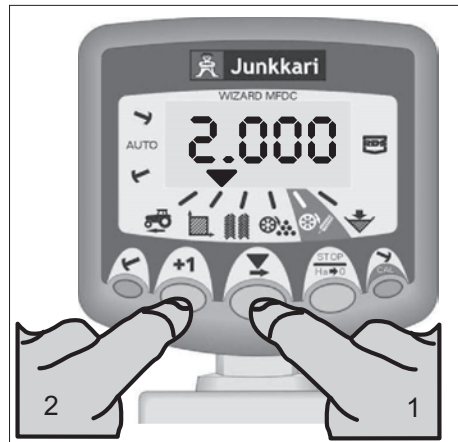

Choose the first digit or decimal  
By pressing 

 2.000,  2.000,  2.000,  2.000, etc

Change the digit value or the location of the decimal by holding down 

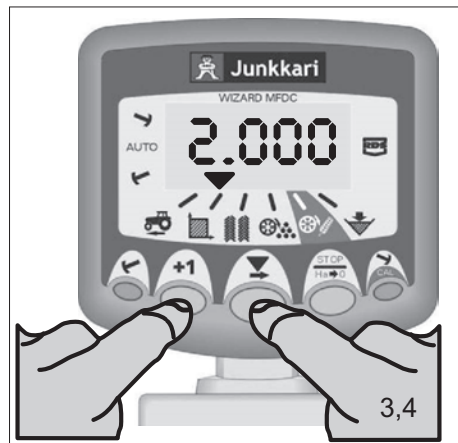

 2.100,  2.200,  2.300,  2.400, etc

Choose the next digit by releasing 

When you release **+1**  
the programming will end and the values you  
input will be stored in the device's memory.

## 6 TRAM LINE MARKING

There are 4 ways to mark tram lines: symmetrical, asymmetrical on the left, asymmetrical on the right and the 18 metre system.

The tram line rhythm factor can be programmed to be from zero (0) to fifteen (15) in all the other modes except the 18 metre system.

The display will show the default value  in 10 seconds (if the total surface area has not been chosen).

Selection of the asymmetrical tram line markers is indicated with a dot between the left tram line round number and the right tram line round number.

The use of the asymmetrical left and right tram line markers is selected during programming.

### 1. THE MANUALLY INCREASABLE TRAM LINE COUNTER VALUE

Press **+1**, and the tram line counter value will increase by one.

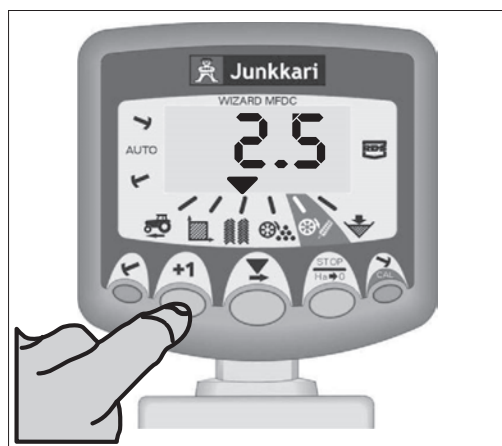

### 2. STOPPING THE TRAM LINE COUNTER

Stop the tram line counter by pressing **STOP**  when the seed and fertilizer drill needs to be raised.

The row marker function is now stopped as well. When the counters are stopped, raising or lowering the machine does not affect either of them.

After pressing the button, "STOP" flashes on the display.

To continue driving according to the mode chosen, press the button **STOP**  again.



## 6.1 SYMMETRICAL TRAM LINE MARKING

Two seed feeding devices near both of the spraying tractor's tires are closed for the duration of the tram line marking. Tram line marker programming in section 5.5.

The monitor beeps once when the tram line marking is started, and the display will continue flashing through the whole round.

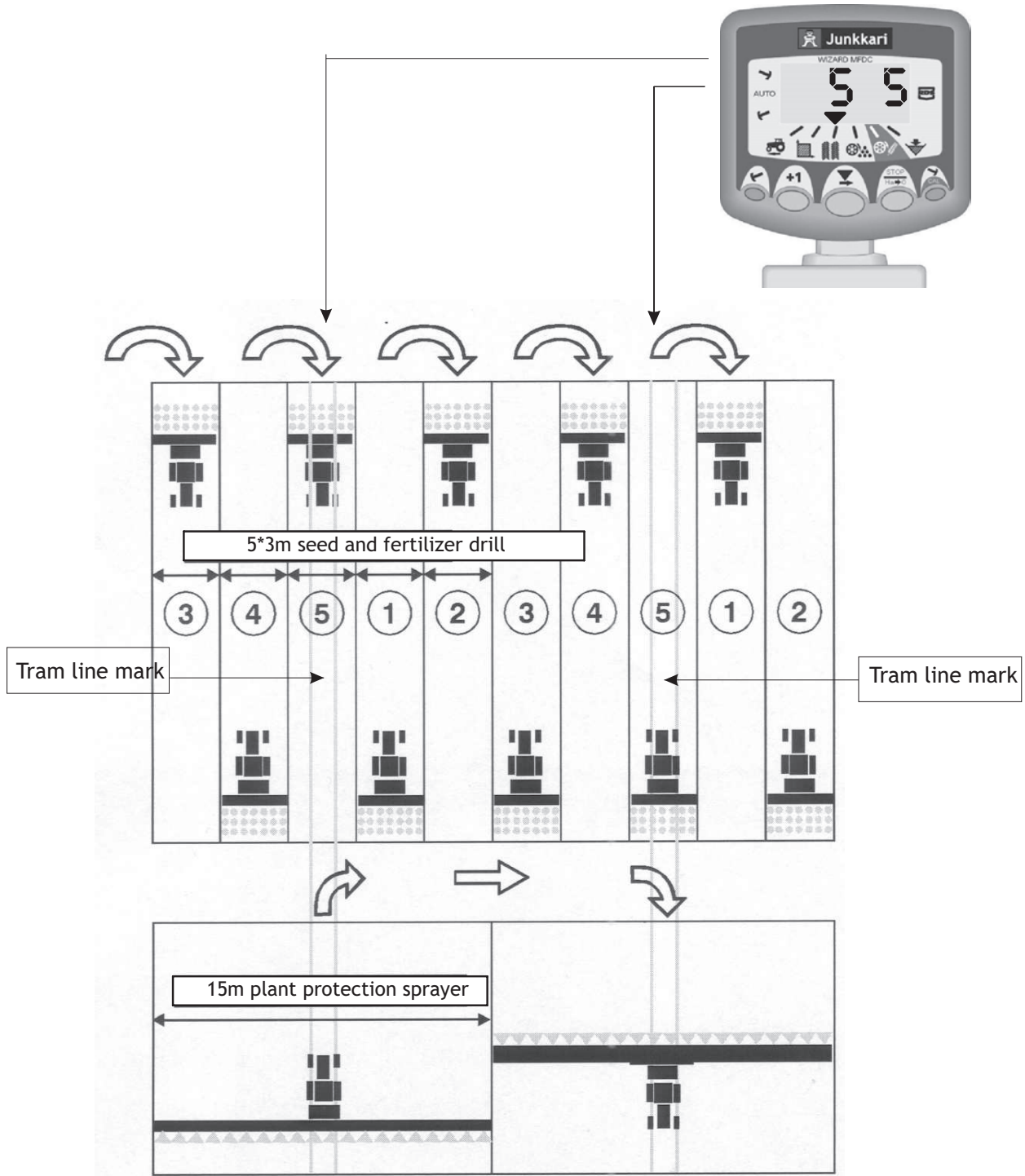



## 6.2 ASYMMETRICAL TRAM LINE MARKING ON THE LEFT

Two seed feeding devices are closed from the left side of the seed and fertilizer drill during rounds 6 and 1 when the spraying tractor is driven over the seam of the sixth (6) and the first (1) sowing round. Tram line marker programming in section 5.5

The monitor beeps once at the beginning of each marking round, and the display will continue flashing through the whole round.

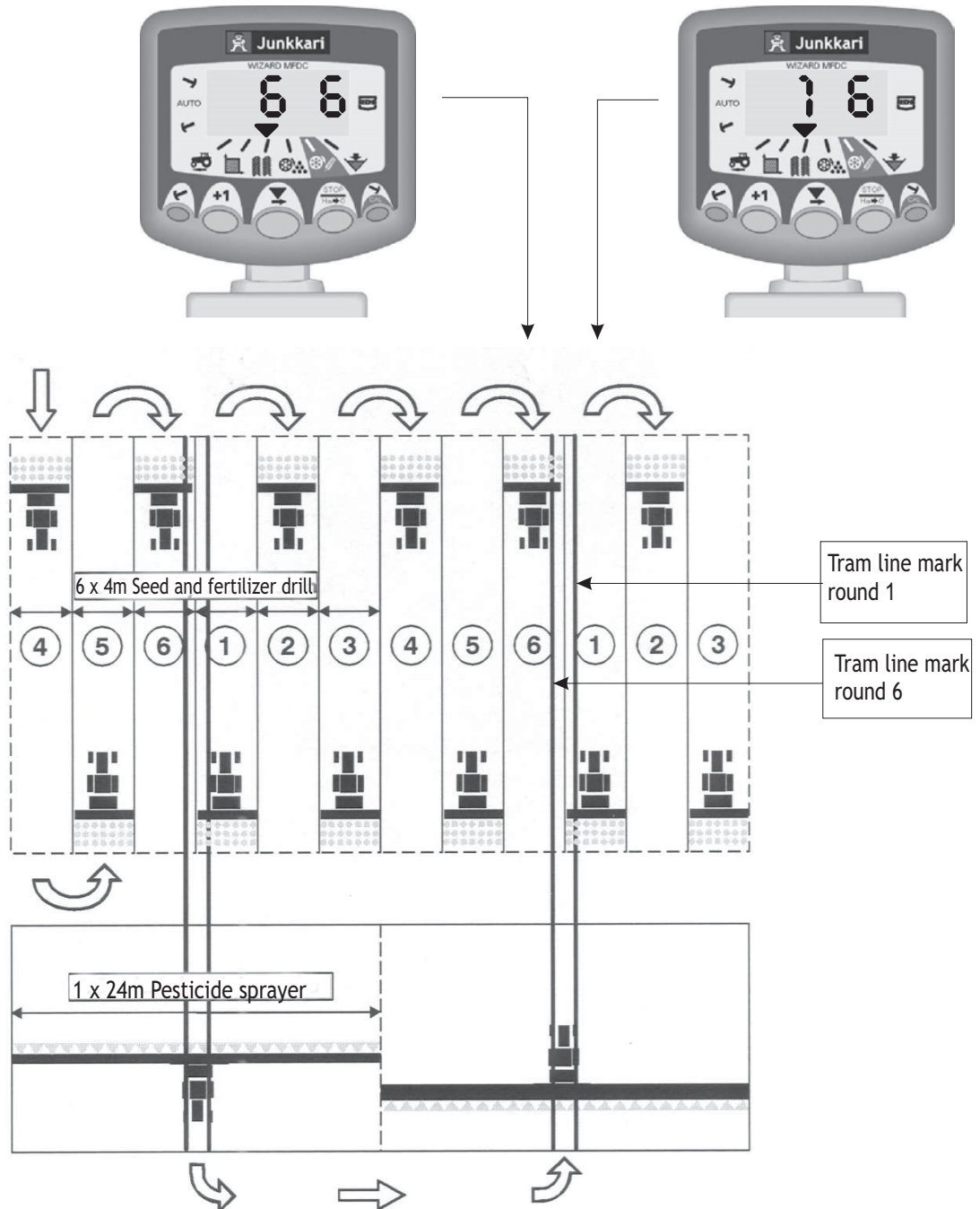

### 6.3 ASYMMETRICAL TRAM LINE MARKING ON THE RIGHT

Two seed feeding devices are closed on the left side of the seed and fertilizer drill during rounds 6 and 1 when the spraying tractor is driven over the seam of the sixth (6) and the first (1) sowing round. Tram line marker programming in section 5.5.

The monitor beeps once at the beginning of each marking round, and the display will continue flashing through the whole round.

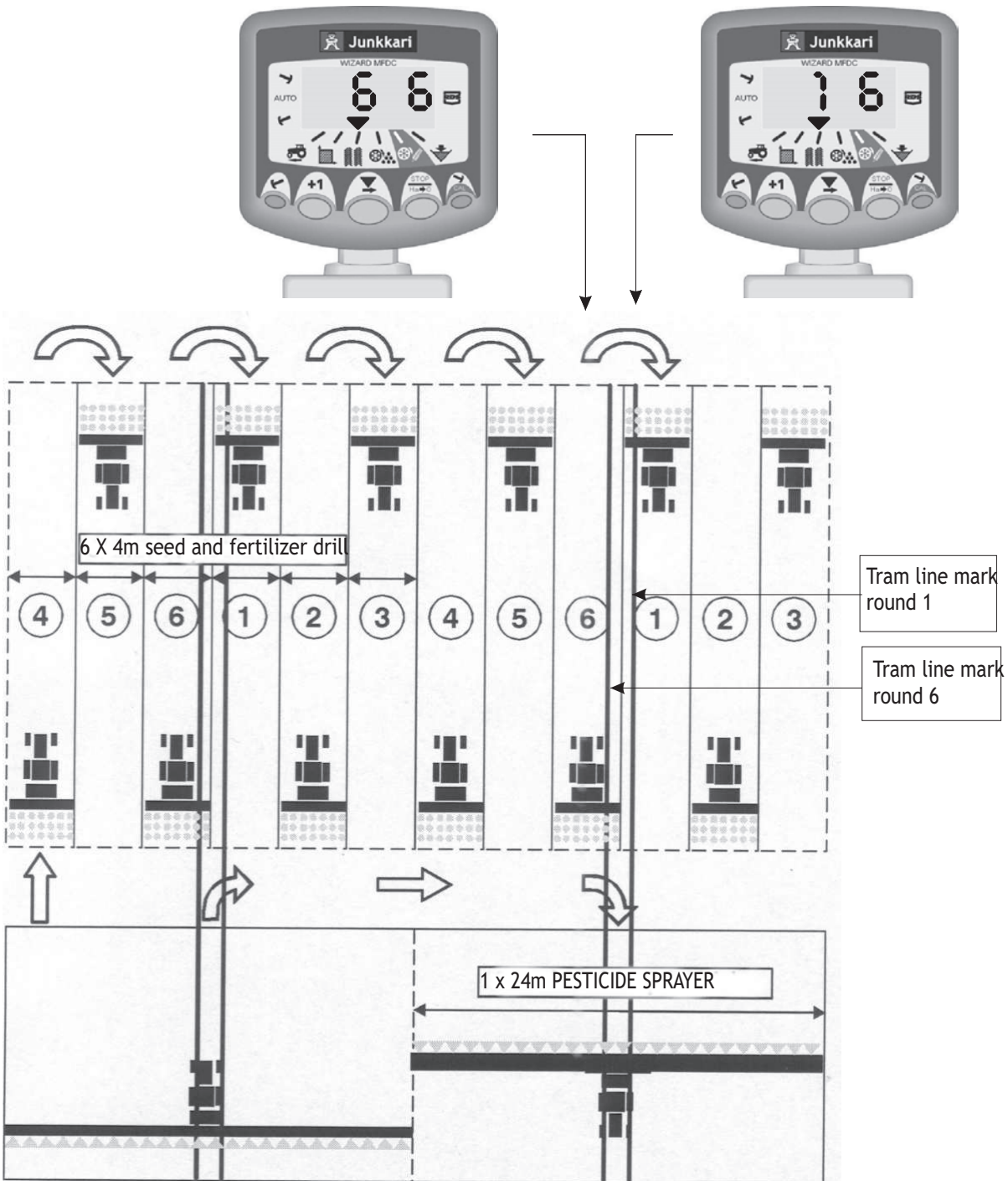

## 6.4 TRAM LINE MARKING FOR THE 18 METRE SPRAYING SYSTEM

The method is used when the seed and fertilizer drill is 4 and the sprayer 18 metres wide. In this case, the width of the drill cannot be multiplied to equal with the width of the sprayer. Therefore, the tram line switches must be installed asymmetrically on the sides of the drill's centre line. The seed and fertilizer drill must have two sets of tram line switches on each side of the machine, and the centre lines of the spray lines come in the middle of the drill's halved working width.

(2 x2 right side seed feeding devices close during rounds 3 and 16, and 2 x 2 left side seed feeding devices close during rounds 7 and 12).

The method requires you to turn left at the end of the first round.

NOTE! When turning left at the end of the first round, cycle the controller to round 10 before beginning.

The monitor beeps once at the beginning of each tram line marking round. The display will continue flashing through the marking round.

Programming in section 5.5.

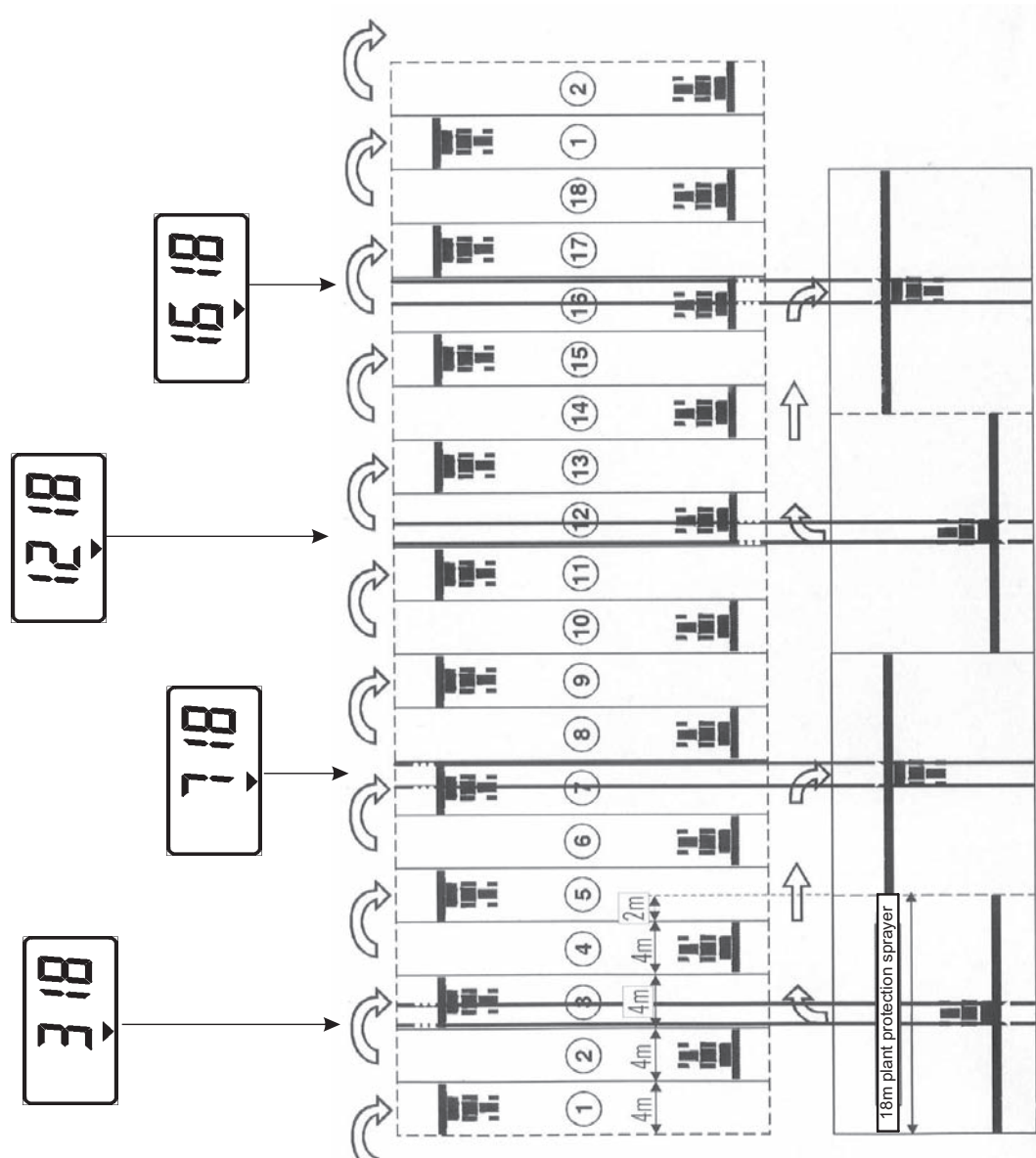

## 6.5 PROGRAMMING THE TRAMLINES

The circle of the tramlines can be programmed from one (1) to fifteen (15), asymmetrically either to the left or right.

The marking can be programmed also for an 18-meter system.

1. Select  action

2. Keep **+1** pressed  
The monitor starts the programming after 3 seconds.

3. Press  and wind the type of marking; SY symmetrical, AL asymmetrical left or AS asymmetrical right.

4. Keep **+1** still pressed, release  for a moment and press it again. Change the correct number on the display. If you want the marking off, wind to value 0.

5. When you release the buttons, the selections are saved.

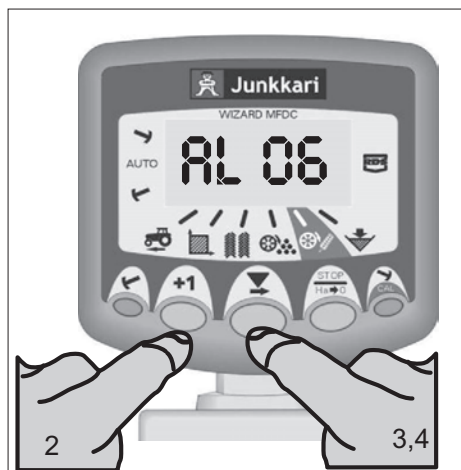
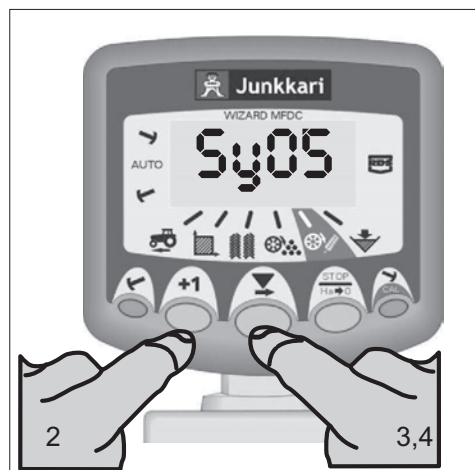
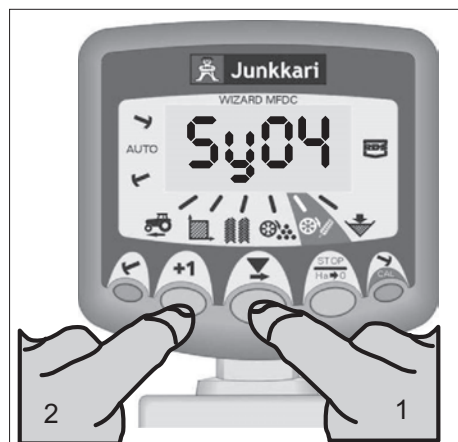

The marking can be programmed also for an 18-meter system, but in this case you need 2 additional switches.

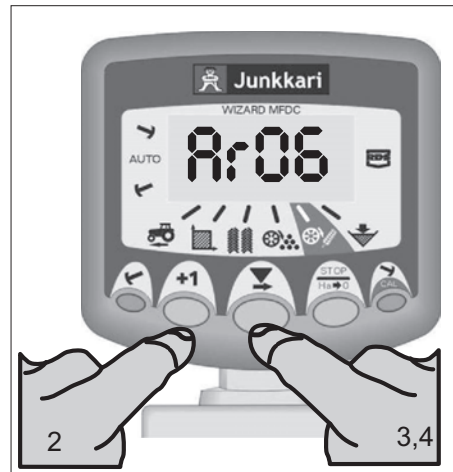

... In this case select As18 on the display.

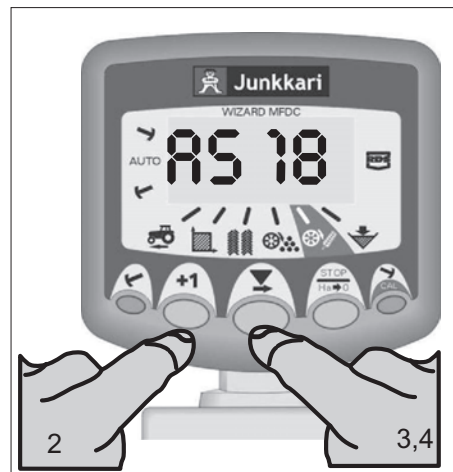

## 7 FERTILIZER SHAFT MONITORING/ALARM

### 1. FERTILIZER SHAFT MONITORING



Alarm with the default setting: if the fertilizer shaft stops for more than 40 seconds, the controller beeps 5 times and switches from the current function to the function.

Shut down the alarm by saving the shaft rotation speed again, choosing another function or turning off the controller and restarting it.

Alternatively, you can switch the alarm off by pressing and holding **STOP** **Ha** for 5 seconds.

The function will show the message "OFF" on the display. The alarm will remain off until the controller is switched off and back on again.

A speed under 2 km/h will prevent the use of the alarm.

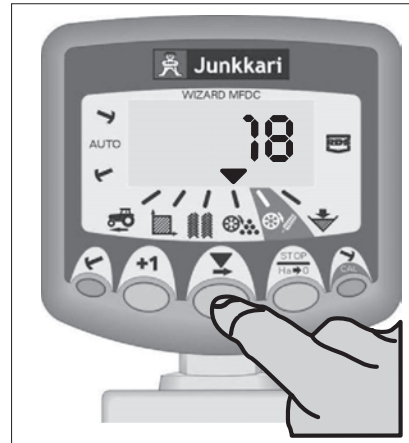

### 2. SETTING THE LOW SPEED ALARM

Choose function.

HOLD **+1** DOWN.

The monitor will start the programming function in 3 seconds.

Press to choose digit or decimal.

2:000, 2:000, 2:000, 2:000, etc

Hold down and change the value or the location of the decimal.

2:100, 2:200, 2:300, 2:400, etc

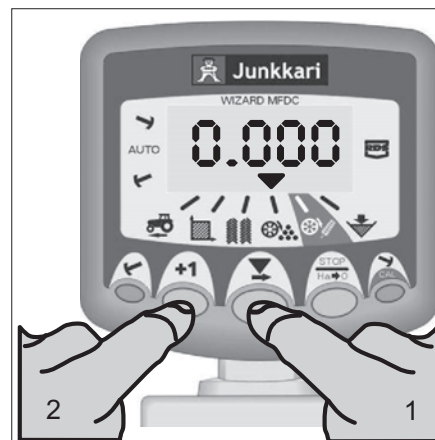

To choose the next digit, release and repeat the procedure, if necessary.



## 8 SEED SHAFT MONITORING/ALARM

### 1. SEED SHAFT MONITORING



Alarm with the default setting: if the seed shaft stops for more than 40 seconds, the controller beeps 5 times and returns from the current menu to the default value of the function .

Shut down the alarm by saving the shaft rotation speed again, choosing another function or turning off the controller and restarting it.

Alternatively, you can switch the alarm off by pressing and holding  for 5 seconds.

The  function will show the message “OFF” on the display. The alarm will remain off until the controller is switched off and back on again.

A speed under 2 km/h will prevent the use of the alarm.

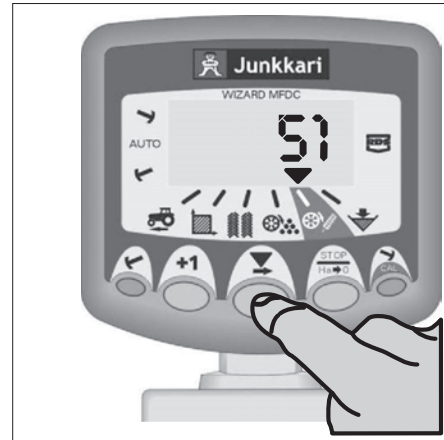

### 2. SETTING THE LOW SPEED ALARM

When function  has been selected, repeat the steps in part 2 of the previous section.

**NOTE!** The speed functions of the seed and fertilizer shafts are a part of the tram line marker mechanism, so the monitor will not display the speed of either of the shafts when tram line markings is engaged. The alarm will also be INOPERATIONAL.

## 9 MACHINERY GUARD

### 1. MACHINERY GUARD



The machinery guard monitors the ratio of rotation speeds of the fertilization and seed-side feeding axles; thus, it monitors mainly the condition of the gear box. The function will sound an alarm if the ratio changes more than what has been set in basic settings point 6. By default, a deviation of 25% is allowed.

In an alarm, the cursor moves to the channel,  and the display flashes "err" and the current ratio number. At the same time, the controller beeps 5 times.

In Maestro sowing fertilizers, the guard must always be re-programmed when the seed-side feeding amount is changed. However, this is easy to do during the seeding.

### 2. SETTING THE MACHINERY GUARD

Programming the alarm takes place in work position while the machine is moving, i.e. it can be done during a normal seeding situation.

1. Move to channel 5 with button 

2. Press  , so that the ratio number starts to change.

3. When the reading stabilizes again after a moment, press the  button again, which displays the message "DONE" on the display and the value is saved.

NOTE! The calibration must always be redone when the rotation speed of the seed-side feeding axle is changed, i.e. when the kg/ha value is changed.

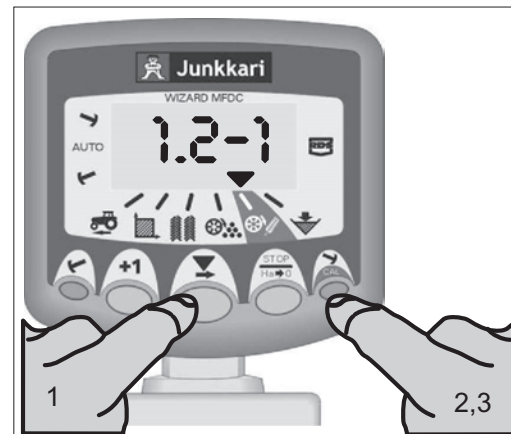
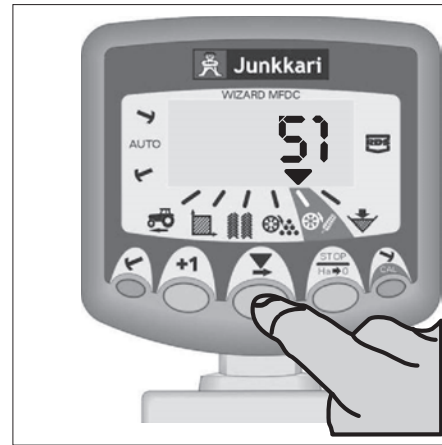

## 10 TANK FULLNESS

### 1. TANK FULLNESS



If the fullness of either the seed or fertilizer tank drops under the sensor range (sensors are attached to the sides of the tanks), the controller will beep 5 times and return from the current menu to the function  default value.



### 2. TANK LEVEL GUARD ON / OFF

Choose the  function.

press and HOLD DOWN **+1**.

press  and choose 0 or 1.

0 = guard inoperational

1 = guard operational

The display will be empty when the alarm function is off.

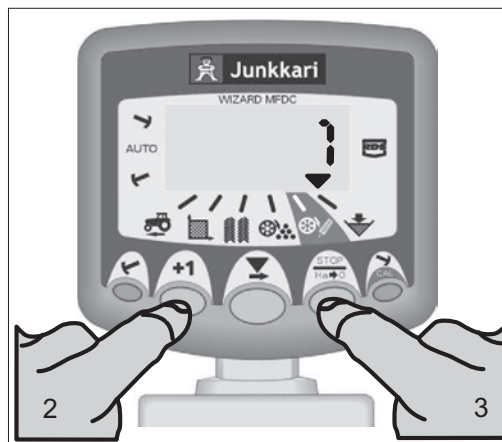

# 11 ROW MARKING

The row marking function is on and set to manual when the Wizard is turned on.

When the row markers are set to manual, only one of the markers (the right or the left) is used.

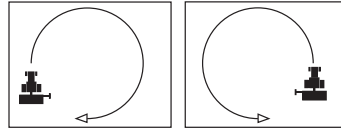

When the row markers are set to automatic, the used marker changes when the machine is raised. Automatic drive starts from either the right or the left.

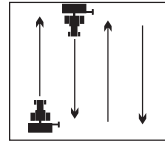

When row marks need to be made on both sides of the machine, the markers are forced down simultaneously.

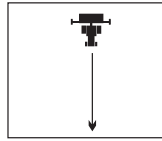

## 1. CHOOSE MANUAL ROW MARKING FUNCTION

Press briefly either  or  (less than 3 seconds).

If the row marks are continuously done on the right side of the machine, press the right button. If they are done on the left, press the left button.

The function can be turned off by pressing the appropriate button briefly again.

The flashing of the row marker symbol indicates that the solenoid valve will remain open (marker down) until the machine is raised.

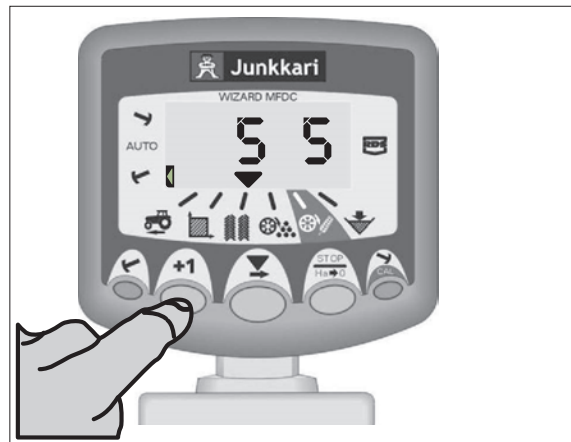

## 2. CHOOSE AUTOMATIC ROW MARKING FUNCTION



Press and hold down either  or  (more than 3 seconds)

If the first row mark is done on the right side of the machine, press the right button. If it is done on the left, press the left button.

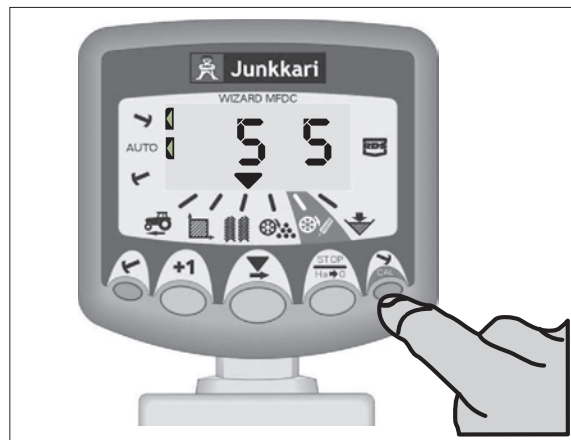
The function can be turned off by pressing and holding the appropriate button again.



### 3. CHOOSE SIMULTANEOUS MARKING OF BOTH SIDES

Press both the row marking buttons  and  consecutively for a short time (less than 3 seconds).

If you wish to switch to another marking function (for instance at the end of the field), press the button/buttons according to the desired method, see sections 1 and 2 on the previous page.

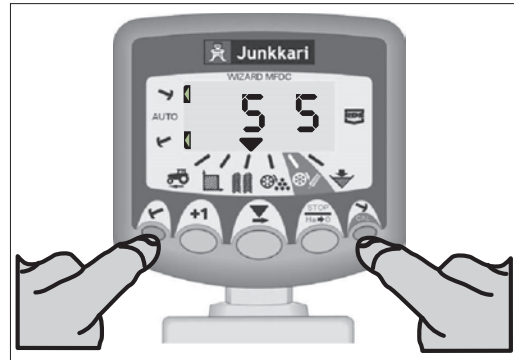

### 4. RAISING THE MACHINE WITHOUT DISTURBING THE MARKING CYCLE

If you need to raise the machine without disturbing the marking cycle, press **STOP**  
**Ha→0**

When the row marking program has been stopped using this button, the program will not register the raising of the machine even though the markers are raised and lowered with the machine. The tram line marking will be program stopped as well.

After pressing the button "STOP" will flash on the display.

Press the **STOP**  
**Ha→0** button again to continue driving according to the mode chosen.



### 5. TURNING THE FUNCTION ON AND OFF

The row marking function is turned on and off by pressing and holding both of the row marking buttons for more than 3 seconds.

Display: see pictures below.



ON



OFF

## 13 MAINTENANCE

### READ THE SAFETY INSTRUCTIONS



The Junkkari Maestro 3000 and 4000 models are equipped with repair and maintenance supports, which must be installed on the lifting cylinder piston rod when servicing, adjusting or repairing the machine. The repair and maintenance supports must be used if you need to go under the machine, for example, to replace the wearing parts of the coulters. The hydraulics alone do not provide sufficient support during maintenance, adjustment or repair work.

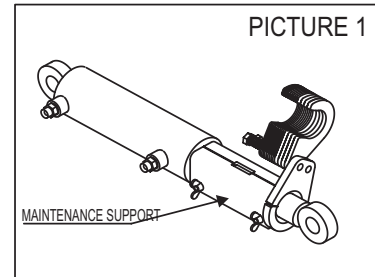

Picture 1 shows the maintenance support installed on the cylinder piston rod. Before installation, the machine has to be fully raised and the sliced sheets turned away from the piston rod. The maintenance support can be locked in place with a screw and a butterfly nut.

Picture 2 shows the location (under the left platform at the back) where the support is kept.

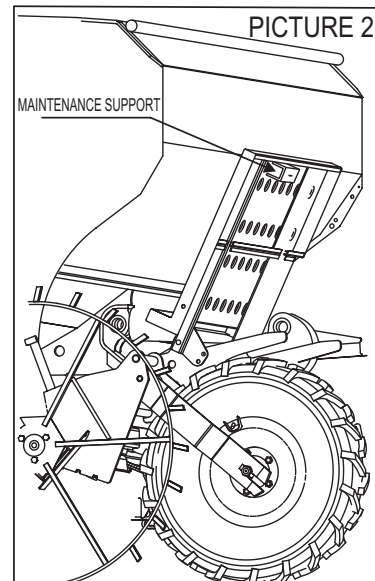

### 13.1. LUBRICATION

Thorough lubrication prevents wear and machine failures during the busy sowing season. A high quality multi-purpose grease must be used to lubricate the machine. When beginning lubrication, check that the grease nipples are open and the nozzle of the grease gun is in working order.

The lubrication diagram can be found later in this manual. See section 14, Lubrication diagram.

### 13.2. CLEANING AND STORAGE DURING SEASON OF USE

During its season of use, the machine should not be stored in the rain or outside with the coulters down. This is because moisture will condense on the coulters and plastic pipes and hinder the flow of the fertilizer in the feeding device and coulters. We recommend that you empty the fertilizer tank and raise the machine of the ground after sowing. Drawn machines can be left supported by the hydraulics, if the ball valve of the connection hose is closed and the parking and maintenance supports are used.

The fertilizer side feeder rifles should be opened all the way before beginning to sow and at times during the sowing as well. This way fertilizer that may have stuck on the rifle will come off, the feed amount will stay on an appropriate level and the feeding devices will not be damaged. Clean the feeding device with compressed air after every 200 ha.



## 13.3 REPAIRS YOU CAN DO YOURSELF

### REPAIRING A COULTER

Coulter discs, scraper plates and the wearing parts of a coulters can be replaced separately. When replacing discs, it is recommended that you also replace the bearing of the disc being replaced, the sealing and the protective cap of the hub (PICTURE 1).

A coulters being repaired must be detached from the frame of the drill. This way it is easier and safer to disassemble the coulters. Coulters are fastened to the frame with an M12 screw (PICTURE 2).

If, however, you need to disassemble the coulters under the machine, you must make sure that the machine is adequately and safely supported.

### REPLACING A COULTER DISC AND SCRAPER PLATE

When the coulters has been removed from the frame, detach the coulters disc as follows: Remove the protective cap, which usually becomes unusable in the process and needs to be replaced. Under the protective cup there is an M16 nut, which needs to be removed. After this, you can pull the coulters disc out. The coulters disc bearing is fastened to the bearing housing on the disc with a lockring. Remove the lockring if the bearing must be replaced as well. Check the condition of the sealing on the coulters shaft and replace it if necessary. Assemble the new parts starting with installing the sealing on the coulters shaft. Next, lock the new bearing on the coulters disc with the lock ring, push the disc on the coulters shaft, tighten it in place with the M16 nut and fill the bearing housing with grease. Finally, you need to hammer the protective cup on the disc. Place the protective cup on the hub and strike its centre forcefully with a hammer. This will lock the cup in its place.

At this time, you can also replace the scraper plate of the coulters, if necessary (PICTURE 1). It is attached to the coulters arm with three M10 nuts.

When installing a new scraper plate, it is important that you adjust the sharpened edge to correspond to the coulters disc all the way. The plate springs on the inside and outside of the plate allow for this to be done: you can adjust the plate by tightening and loosening the three M10 nuts. To finish off, check that the coulters disc spins freely.

### REPLACING A PLASTIC BEARING

A plastic bearing is replaced as follows: Remove the M10 screws, which lock the plastic bearing to the coulters bracket. After this you can turn the coulters arm out of the bracket. Remove the worn plastic bearings and install new ones. Lift the coulters arm into the slot in the bracket and attach the M10 screws. Tighten the screws only enough to remove clearance and allow for the coulters arm to fall freely from the upper position.

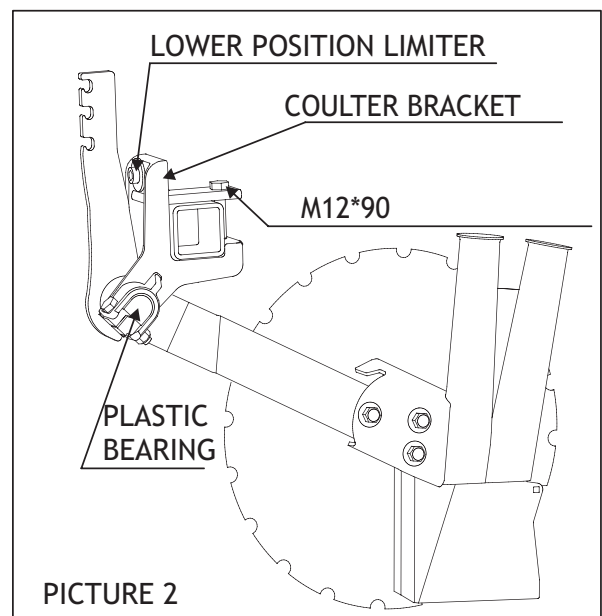
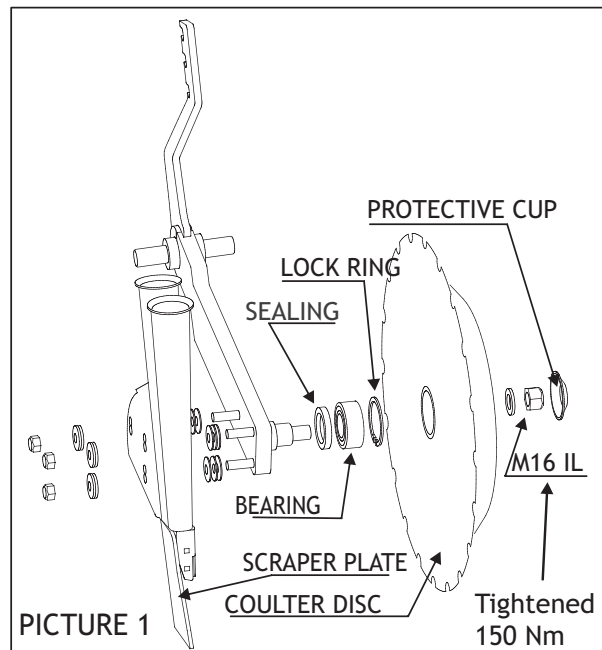

SEED SIDE MAINTENANCE AND ADJUSTMENT

The condition and adjustment of the bottom flaps have a crucial effect on the seed rate. The flaps have been adjusted at the factory, but it is possible that, for example, foreign objects can damage them despite their safety springs. If this is the case, the damaged bottom flap must be replaced. Changes due to minor damage can be corrected with readjustment. You can use the calibration test to get an idea of how even the feed is. If one pile of seeds in the round test trough is visibly different from the others, check the condition of the bottom flap.

REPLACING THE BOTTOM FLAPS

Loosen the locking screw of the adjustment handle in the seed side. This will release the lock and the shaft can be pulled out. When the feed is set to zero, the bottom flap can be replaced. Place the assembled bottom flap in the case and push the shaft back in its place. (PICTURE 3).

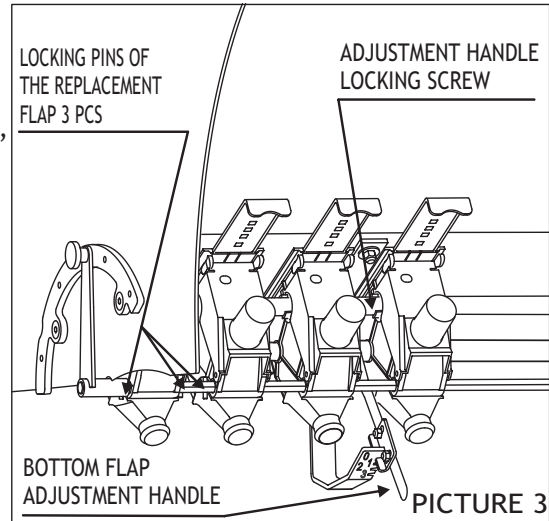

CASE SPECIFIC BOTTOM FLAP ADJUSTMENT

Basic adjustment of the bottom flap spring has been accomplished when the measurement shown in picture 2 is 10 mm. The position of the bottom flap can be adjusted both ways when operating in normal adjustment range. Tightening the screw one full revolution will increase the feed amount by 5 %. Loosening the screw will decrease it accordingly. All bottom flaps of the feeder cases must be adjusted identically. Install the bottom flap adjustment handle to position 1. This way you can check the clearance between the bottom flap and the feeder rifle (ca. 0.5 mm) with your finger. New machines have been adjusted at the factory (PICTURE 4).

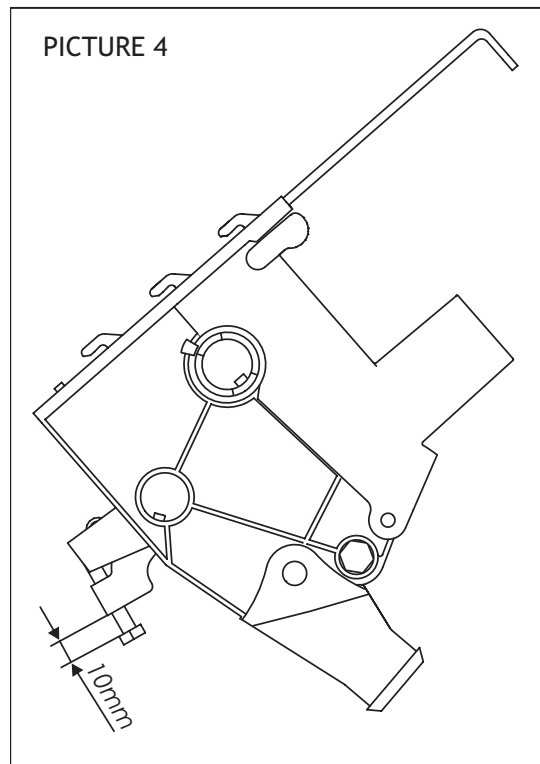

CENTRAL ADJUSTMENT OF THE BOTTOM FLAPS

Use the adjustment handle shown in picture 3. The calibration test sticker gives guideline values for different types of seeds.

REPLACING THE STUDED ROLLERS

First, remove the linch pin of the seed side feeder shaft located at the right side end of the machine. Then, pull the feeder shaft out. Open the cover of the feeding house to remove the studded rollers and the plastic bearings between the rollers and the house (PICTURE 5).

When inserting the studded rollers and plastic bearings back in the feeding house, make sure that 2 of the protruding parts of the bearings face the bottom of the groove. Close the cover, which locks the rollers in their place, and push the feeder shaft back in. Lock it in place with the linch pin at the right side end of the machine.

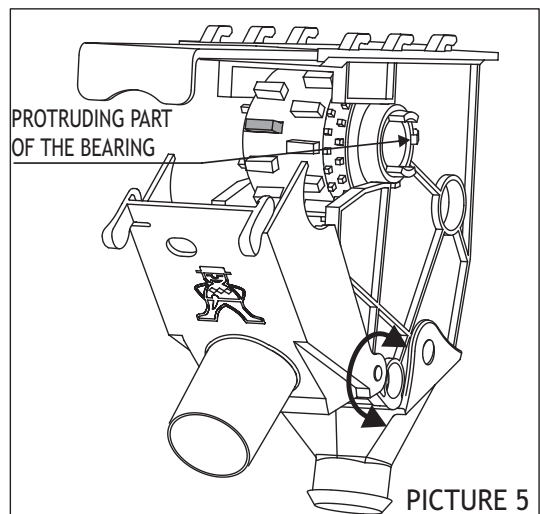

## FERTILIZER SIDE MAINTENANCE AND ADJUSTMENT

The condition and adjustment of the bottom flaps has a crucial effect on the feed amounts. The flaps have been adjusted at the factory, but it is possible that, for example, caked fertilizer or foreign objects can damage the flaps despite their safety springs. If this is the case, the damaged bottom flap must be replaced. Changes due to minor damage can be corrected with readjustment.

### REPLACING THE BOTTOM FLAPS

Remove all of the hair pin cotters from the bottom flap shaft and mark the locations so you can install the parts back in their places. In the seed side, remove the adjustment screw lock and pull out the shaft. When the feed is set to zero, the bottom flap can be replaced. Place the assembled bottom flap in the case and push the shaft back in its place. Make sure that all flaps are installed in the same position. Attach the rest of the parts (PICTURE 1).

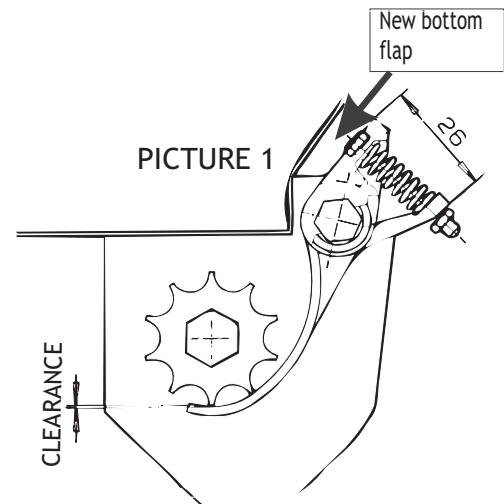

### CASE SPECIFIC BOTTOM FLAP ADJUSTMENT

Basic adjustment of the bottom flap spring is ready when the measurement shown in the picture is 26 mm. The position of the bottom flap can be adjusted both ways when operating in normal adjustment range. Tightening the screw one full revolution will increase the feed amount by 7 %. Loosening the screw will decrease it accordingly. All bottom flaps of the metering devices must be adjusted identically. Install the central adjustment handle to position 1. This way you can check the clearance between the bottom flap and the feeder rifle (about 0.5 mm) with your finger. New machines have been adjusted at the factory (PICTURE 1).

### CENTRAL ADJUSTMENT OF THE BOTTOM FLAPS

If the calibration test results differ considerably from the guideline values given in the sow chart, the machine can, within certain limits, be adjusted to meet the chart values. It is natural that seeds and fertilizers may vary greatly in quality and thus flow-ability. Therefore, slight differences are not reason enough to adjust the machine. The adjustment can be done by moving the lock of the adjustment lever. Tightening decreases the feed by 1.5 %/1mm. Do not tighten so much that there is no longer clearance between the rifle and flap when the lever is in position 1 (PICTURE 1).

### REPLACING THE PLASTIC SEAL OF THE FERTILIZER SIDE FEEDING DEVICE

Remove the feed adjustment frame nut from the end plate along with all the cotter pins. Pull the shaft out through the opening in the end plate. Insert a thin table knife between the plastic seal (located in the groove on the side of the feed chamber) and the locking ring and force the ring out. The seal can now be replaced.

WHEN LIFTING THE SEED AND FERTILIZER DRILL, MAKE SURE THAT THE CAPACITY OF THE LIFTING DEVICE USED IS SUFFICIENT TO ENSURE SAFETY DURING THE PROCEDURE.



REPLACING THE TIRES

It is easiest to replace the tires when the machine is empty and on a solid surface. This will allow you to raise the roller wheels approximately 20 cm off the ground using the lifting cylinder. You must, however, turn all of the sheets off the piston rods and pull the cylinder all the way in (PICTURE 2). This will allow unobstructed access to the fastening nuts. The nuts are secured with locking plates, which will have to be removed first. After detaching the locking plates, remove the nuts and pull the wheel off. Replace or remove the wheel and install it back in the grooves in the wheel arms. Remember to install the washer and the locking plate under the nut.

If a wheel needs to be replaced when the machine is not empty or on a solid surface, the wheel can be extracted as follows: Place a 15 to 20 cm high and sufficiently long (50 cm) block under the undamaged wheel of the wheel pair, and reverse the machine carefully on the block.

Make sure the machine stays on the block, engage the tractor's parking brake and place stopping blocks in front of and behind the roller wheels to keep the machine still. After this, replacing the tire will be easy (PICTURE 3).

Picture 4 shows how the tire is attached to the clevis. When fastening the tire, remember to bend the other end of the locking plate to the groove in the clevis and the other end over the lug's shoulder.

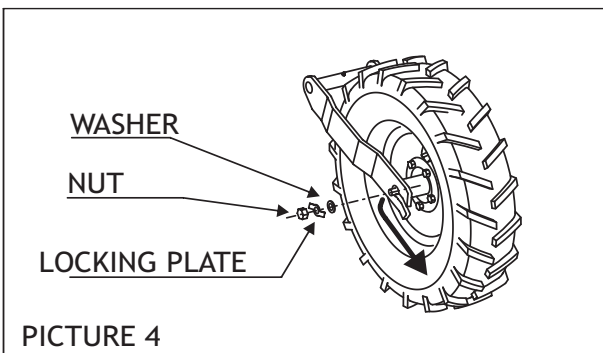
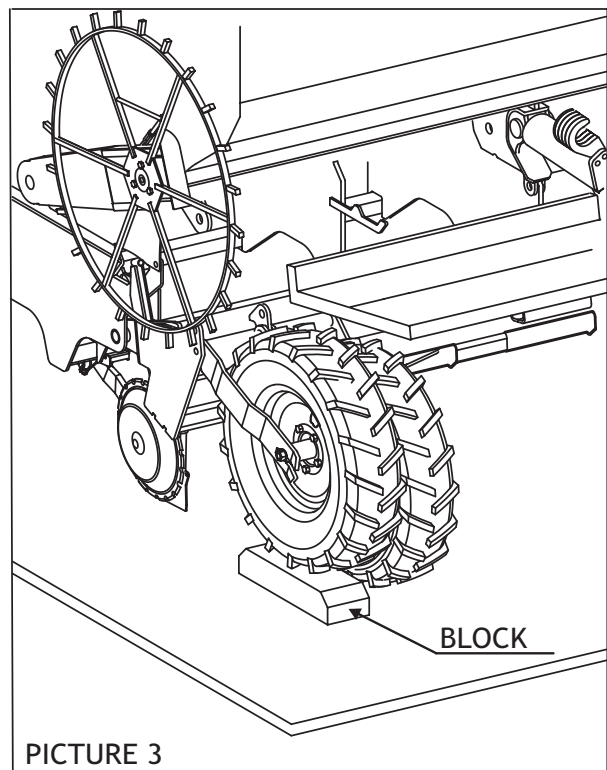
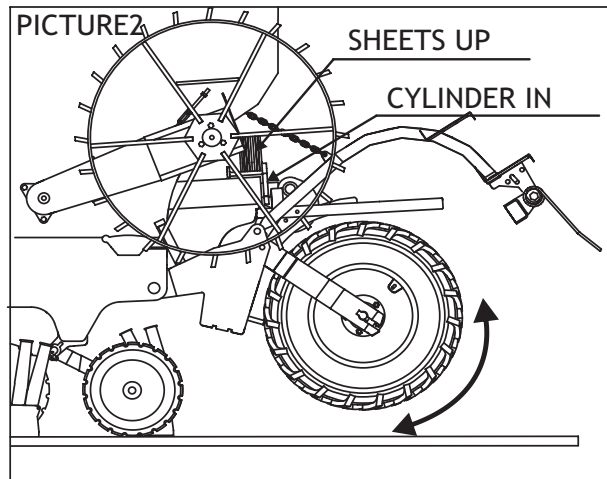

## TIRE AIR PRESSURE

The air pressure directly affects the machine's total surface pressure, which, in turn, affects the field. Bear in mind, however, that lower surface pressure lowers the load-carrying capacity of the tire. The load-carrying capacity of a tire is in direct relation to its travel speed: when the air pressure is low, the travel speed has to decrease as well. The values below are determined according to the machine's weight and the travel speed of 30 km/h, which is the structural maximum speed of the tires.

On rocky ground, it is recommended that you use maximum tire pressure.

Tire pressures should be checked with a gauge at the beginning of every sowing period, and visually every day during the period of use.

		Recommendation	Max.
7.50-16	6ply	180 kPa	280 kPa

## 13.4 ELECTRICAL DIAGRAMS

Electrical diagram, lights:

1. LEFT INDICATOR LIGHT
2. NOT IN USE
3. FRAME
4. RIGHT INDICATOR LIGHT
5. RIGHT REAR LIGHT AND SYMBOL LIGHT
6. BRAKE LIGHT
7. LEFT REAR LIGHT

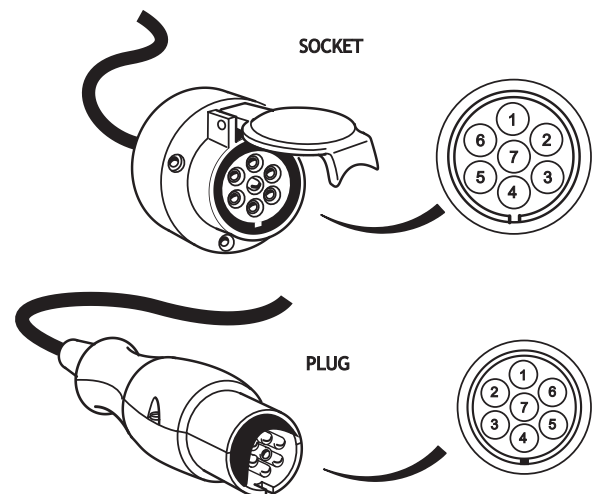
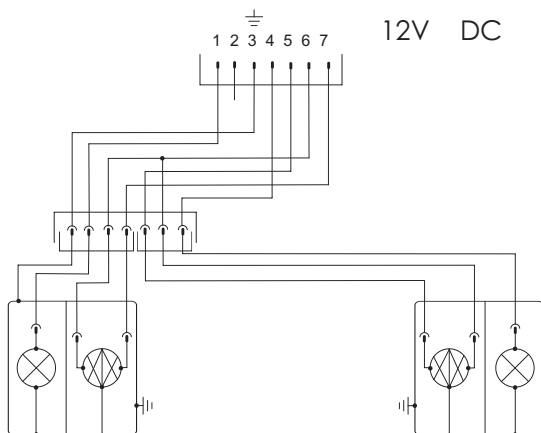

# SOCKETS

## 16 PIN DATA TRANSFER CABLE SOCKET

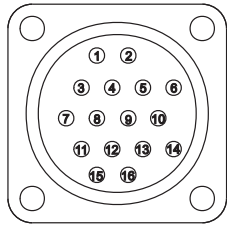

NUMBER	WIRE COLOUR
1	RED
2	RED-BROWN
3	YELLOW-RED
4	GREEN
5	VIOLET
6	BROWN
7	WHITE
8	YELLOW
9	TURQUOISE
10	PINK
11	BLACK
12	GRAY
13	GREEN-RED
14	BLUE
15	ORANGE
16	RED-BLUE

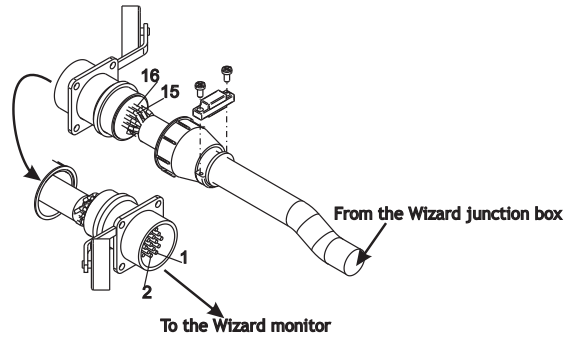

## 3 PIN ELECTRICAL SOCKET

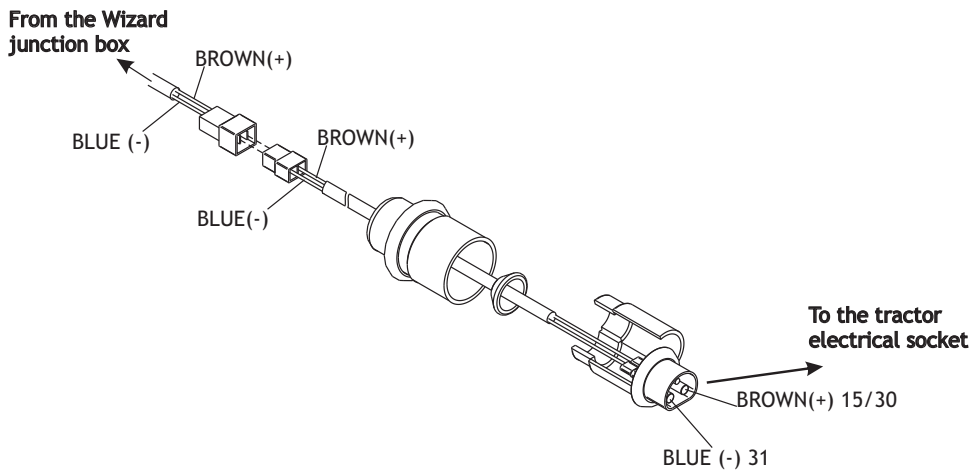

## TRAM LINE MARKER CONNECTORS

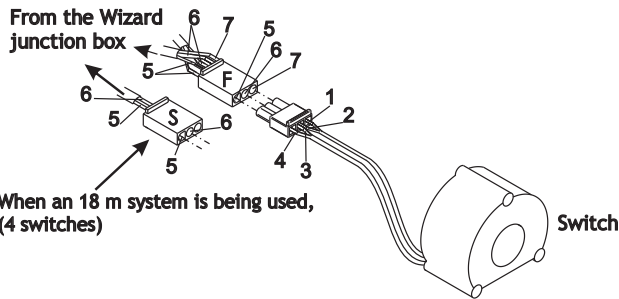

Number	WIRE COLOUR
1	BLACK
2	DARK BLUE
3	PURPLE
4	LIGHT BLUE
5	BROWN
6	BLUE
7	YELLOW-GREEN

## ROW MARKER SOLENOID VALVE CONNECTOR

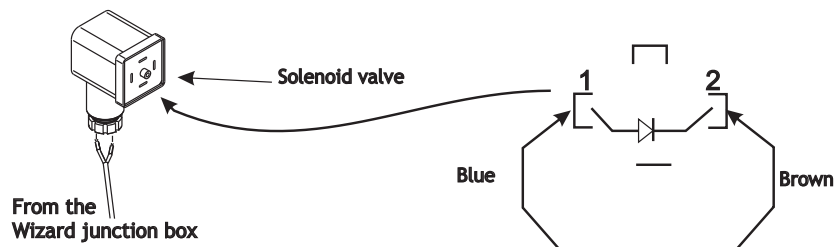



# CIRCUIT BOARD CONNECTIONS WIZARD



# JUNKKARI

Junkkari "2002"  
Junction Box  
S/AC/306-3-002  
WIRING LABEL

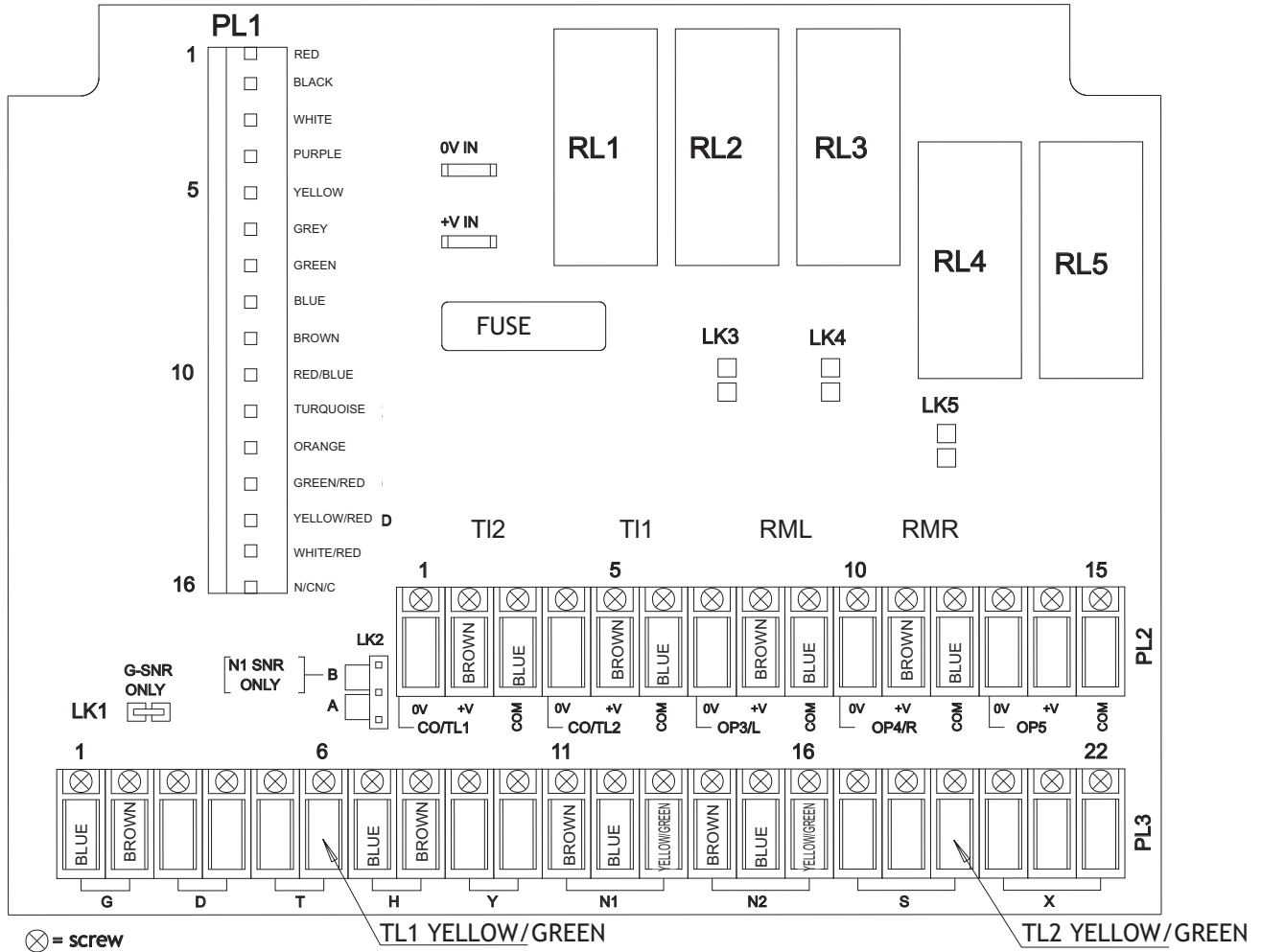

- TL1 TRAM LINE LEFT
- TL2 TRAM LINE RIGHT
- G LIFTING SENSOR
- H SPEED SENSOR
- RML ROW MARKER LEFT
- RMR ROW MARKER RIGHT
- N1 TANK GUARD SEED

# CONNECTION DIAGRAM, CIRCUIT BOARD WIZARD:

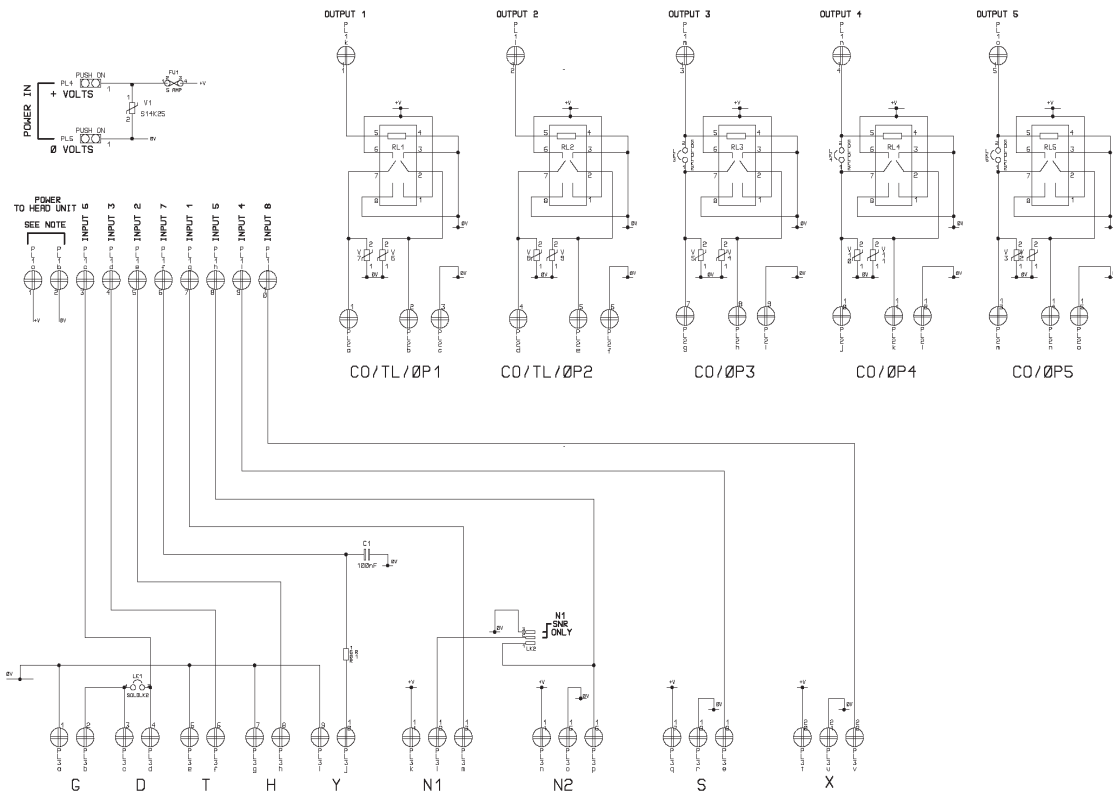

# 14 LUBRICATION DIAGRAM

Maestro 3000: 39 grease nipples  
Maestro 4000: 49 grease nipples

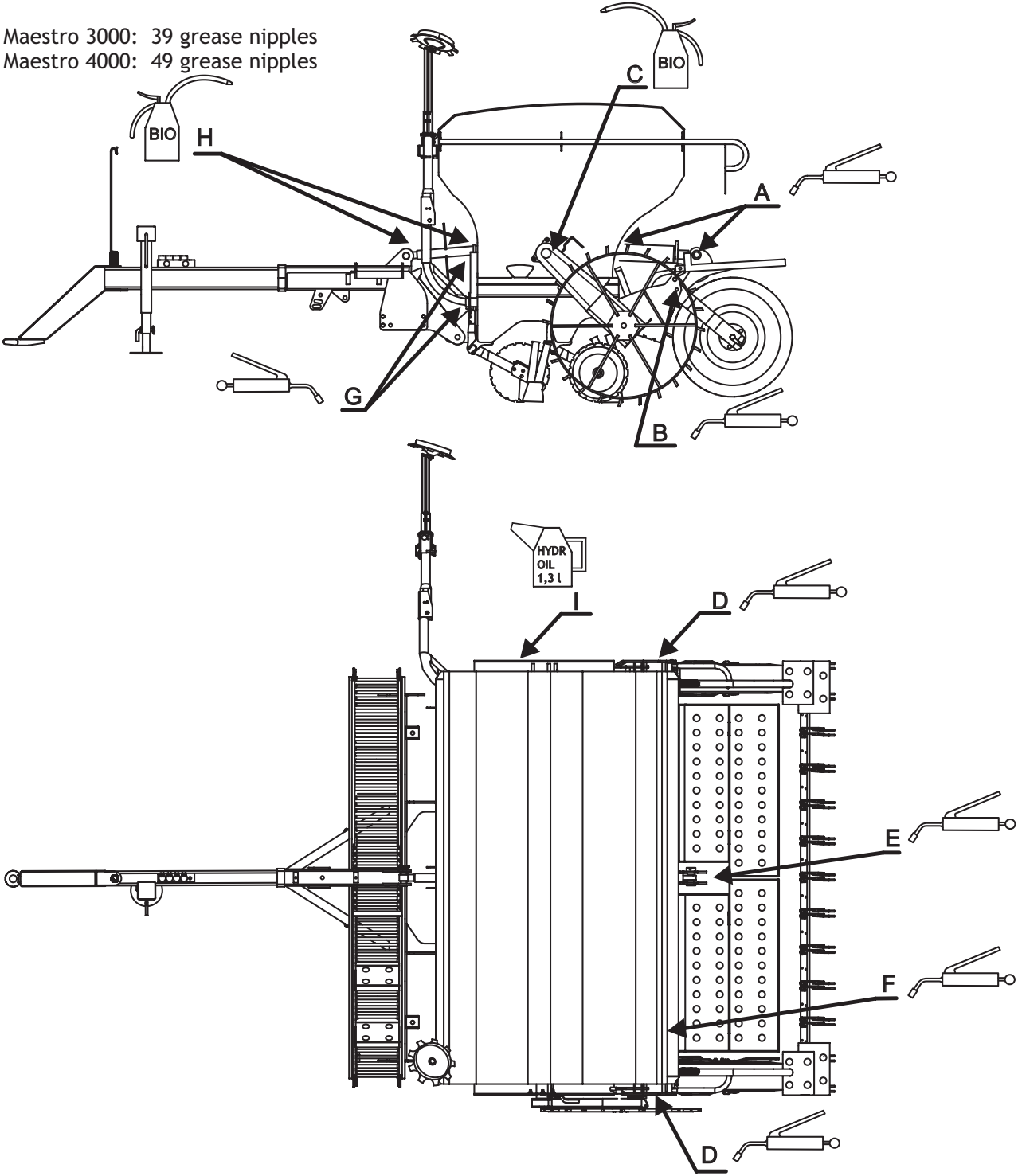

All greasing and lubrication items have been designed to be as user friendly and safe as possible.



Always use the maintenance support when lubricating or doing other maintenance Work on the machine while it is in transport position, i.e. Raised.

Lubrication table

ITEM (number of nipples)	MAESTRO 3000/4000
A. Lifting cylinder nipples, 2 pcs	After 100ha or 2 times in a season
B. Roller wheel arms 12 /16 pcs	After 100ha or 2 times in a season
C. Ground wheel chain 1 pc	2 times in season, and every time the machine is washed or has gotten wet
D. Frame and roller wheel end bearing 2 pcs	After 100ha or 2 times in a season
E. Frame and roller wheel middle Bearing 1 pc	After 100ha or 2 times in a season
F. Bearings of swing plate axles 6/8 pcs	After 100ha or 2 times in a season
G. Row marker cylinder nipples 4 pcs	One time in a season
I. Gear box	Oil change twice per month of use
H. Push rod threads, 2 pcs	Twice in a period of use, and every time the machine is washed or has gotten wet
K. Ground wheel axle	Lubrication after seeding season Note! Lubrication can be done best when the ground wheel is at the lower position.
L. Plain bearings in the swing plates 12/16 pcs	After 100ha or 2 times in a season

All lubrication items must be lubricated before storing the machine for the winter.

The coulters and roller wheels are continuously lubricated and protected by seals. They do not need maintenance when it comes to lubrication. If the coulter disc or roller wheel ring is replaced, the old vaseline should be removed and new added.

Lubricate the threads with a high quality vaseline or a suitable general lubricant. After lubrication, rotate the threads to their extreme positions to spread the lubricant evenly. We recommend you use bio oil on chains.

The Maestro frame is equipped with two extendable support legs. They can be used to make transporting, storing and servicing (for example when lubricating the push arm threads) the machine easier.

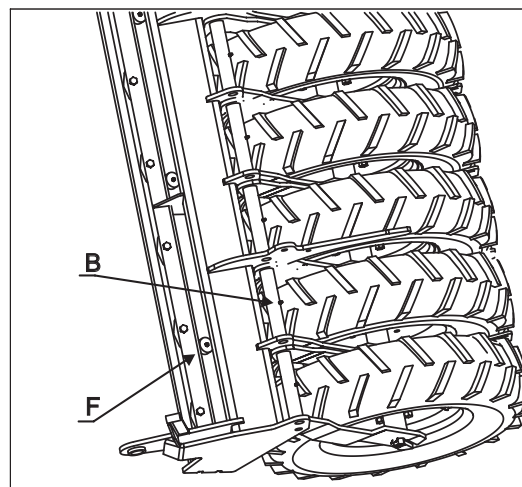

High quality hydraulic oil should be used in the gearbox.  
 It is recommended that oil is replaced every spring before seeding, because water may condensate in the gear box during winter.

The volume of the gearbox 1.3 litres, and the oil level can be checked from the sight glass. If no oil is visible in the sight glass, enough oil must be added so that the surface of the oil rises to the centre of the sight glass when the machine is level.

Recommended oils:

Neste Hydraulic 32 Super  
 Mobil DTE 24

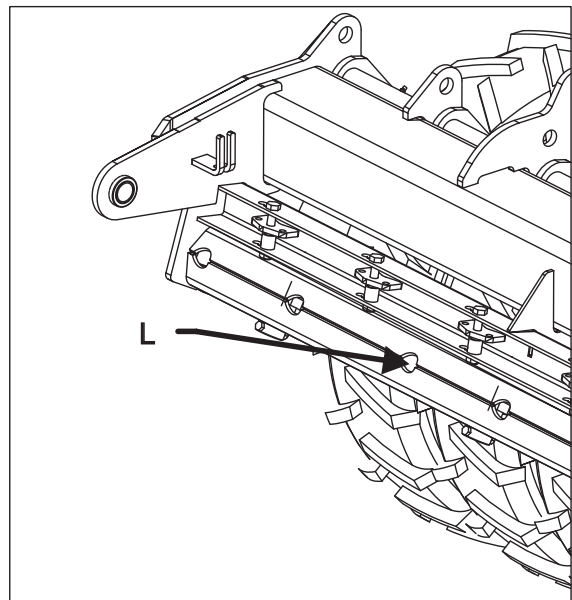
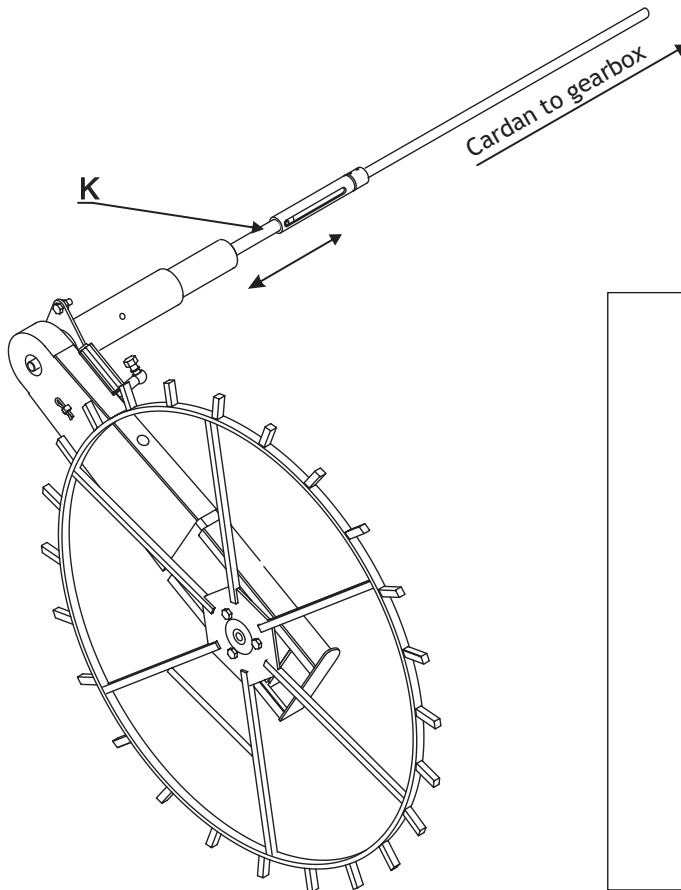
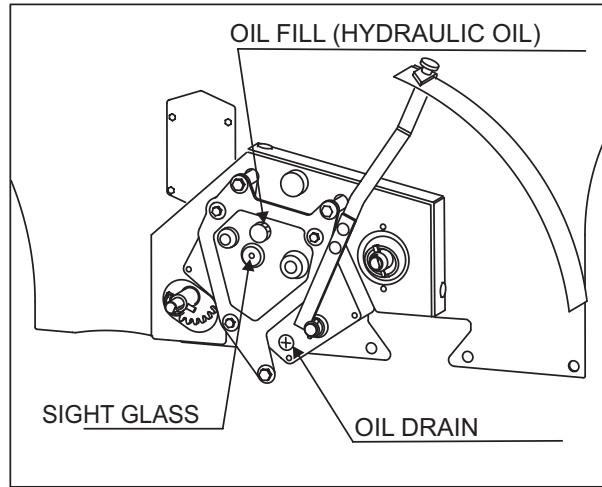

## 15 CLEANING AND STORAGE

### 15.1 CLEANING

When the seed and fertilizer drill is emptied, it can be washed with water from the inside and the outside. Electrical equipment is cleaned by wiping with a damp cloth.



**NOTE!** Do not use a pressure washer!  
Electrical equipment must not be exposed to water or other cleaning agents!

### 15.2. STORAGE

When the machine is not used, it should be cleaned, serviced and stored in a covered location where it will not be exposed to sunlight. Clean the machine thoroughly and inspect the paintwork.

If the paintwork is damaged, it should be repaired. Carry out the basic lubrication procedures. It is recommended that you remove the chains, wash them with a suitable solvent and lubricate them with oil. The tank cover tarpaulin needs to be left open during storage (the machine must be in a place where it is not exposed to rain) to keep condensation water from gathering in the tanks.

Lubricate the lifting cylinder piston rod thoroughly.

When the machine is stored it should be raised to the transport position so that the coulters are in the air. Install the maintenance support of the lifting cylinder (PICTURE 1) and turn the hydraulics ball valve (PICTURE 2) to the off position.

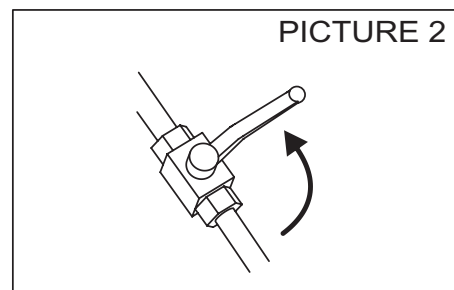
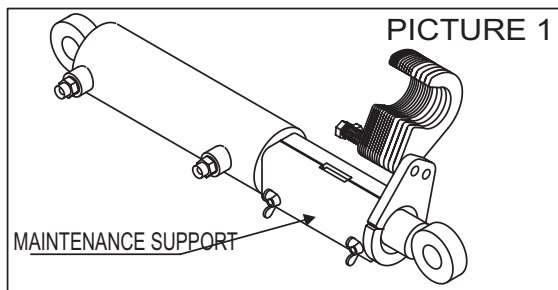

The machine is best protected from corrosion when its surface is coated with mineral or bio-based storage oil.



Don not, under any circumstances, use used oils when storing the machine. Used oils contain sulphur residue and other combustion waste. These substances increase the risk of corrosion to the surfaces. Using synthetic oils is also prohibited.

Store all detachable electronic displays and driver boxes in dry and warm places. Check tire pressures before storing the machine.

Since the storing periods of the seed and fertilizer drill are long, cleaning and storing the machine carefully is especially important for its durability.



## 16 TROUBLESHOOTING CHART

FAULT	CAUSE	REPAIR PROCEDURE
Calibration test will not give the same result as the graphs	Incorrect adjustment	Check adjustment
	Incorrect dir. of rotation	Check direction of rotation
	Incorrect amount of rot.	Check
	Incorrect position of the bottom flap	Check
	Note that the graphs only offer guideline values	Perform the driving test if needed
The machine feeds less than what the calibration test requires	The test was performed incorrectly	Perform the test again
	Incorrect position of the bottom flap or bottom hatch	Check the bottom flap and bottom hatch
The machine feeds more than what the calibration test requires	The test was performed incorrectly	Perform the test again
	Machine vibration may sometimes increase the flow-ability of the seeds	Perform the test by driving
Feed amount differs between the metering devices	The bottom flaps are in different positions	Adjust
	The bottom hatches are in different positions	Adjust
The electric surface area meter is not functioning although the signal light is on	Severed connection	Clean the socket
	Damaged sensor	Repair/replace
	Voltage is under 8V	Check the wiring
The display of the monitor is blank and receives no power	Voltage is under 10V	Make sure the current feed is sufficient
The message "BATT" is on the display	There is enough power to display this message	Check the condition of the power supply and ensure that the current feed is sufficient
The message "PROG" is on the display	An error in the on-board computer's memory	Contact a brand specific service station or retailer
Display flickers during driving	The display does not receive the speed signal: the sensor or magnet is loose, or the chain is loose / broken, or the wire is broken	Repair / reattach
"TL1" flashes on the display	There is dirt or other interfering material in the seed side switches which causes them to function abnormally	Turn the test crank half a revolution (1/2) counterclockwise. Check the switch and replace it if necessary.
	Broken wire	Repair the wire
"TL2" flashes on the display	Same fault as in the previous one, but on the fertilizer side.	See previous repair procedure

Troubleshooting chart

FAULT	CAUSE	REPAIR PROCEDURE
Speed is not shown on the display	Loose magnet	Attach the magnet
	Loose sensor fastener	Attach
	Broken sensor wire	Repair or replace the wire
	Distance between the sensor and the magnet is too great	Make sure that the magnet is attached and adjust the distance appropriately
The tram line counter does not function correctly	See cause of the previous fault	See previous repair procedure
Tram line factor not shown on the display; the monitor not counting tram lines	Tram line marking has been switched off	Choose another tram line factor than OFF
	STOP is active	Press STOP
Surface area meter not displaying surface area	See cause of the fault "Speed is not shown on the display"	See repair procedure of the fault "Speed is not shown on the display"
Incorrect speed and surface area display	Sensor has not been properly calibrated	Recalibrate
The tank guard alarm does not go off when the tank is empty	The function has been switched off	Switch on the sensor
	Broken wire	Repair the wire
The tank guard alarm goes off all the time.	Amount of seeds/fertilizer in the tank lower than the sensor limit	When sowing small seed, switch the tank guard off
The tank guard alarm does not go off	The sensor has been adjusted too close to the bottom of the tank so it is not "sensing" the contents of the tank	Adjust the sensor higher
Bent coulter	The coulter has hit a rock or other obstacle	Replace the damaged part. When reversing, the machine and the interval roller must be raised
Coulter bent sideways Pieces have come off the metal discs of the coulters	The coulter has hit a rock	Replace
	The coulter has hit a rock	Lower your drive speed when driving on rocky ground.
Coulter bearing clearances have become larger	The machine has been turned too sharply with the coulters in the ground	
Coulters become jammed	Worn discs	Replace
	The ground is too wet for sowing	Wait for the ground to dry before sowing
	The coulter pressure is too high because for light or scrambled soil	Lower the speed/adjust the coulter pressure appropriately

FAULT	CAUSE	REPAIR PROCEDURE
Worn scraper plate	Coulter pressure too high	You can lower the plate 13 mm once or replace it
	Working depth adjustment too high	
Metering device is leaking	A large rock or other object (e.g. caked fertilizer) in feeding device	Remove caked material/rock, adjust/repair if necessary
	Bottom flap central adjustment loose/broken	Adjust/repair
Bent harrow	Harrow lowered when reversing the machine	Straighten or replace.
	Run over by the tractor when filling the tank	When reversing, machine and interval roller must be raised.
Tire smokes	A foreign object (rock/ tree stump) in bogie set	Remove the foreign object
Hydraulics do not function as expected	The ball tap is closed.	Open the ball tap.
	Connector is loose or incorrect	Attach, replace with a suitable connector.
	The maintenance support is in place.	Raise the maintenance support.
Fertilizer shaft rotates only half of the time	The other spring in the gearbox is broken.	Replace the spring.
Feeding tube blocked	Soil protection has fallen, the machine has been stored so that there is a steep bend in the feeding tube.	Add the soil protection; if necessary, straighten the feeding tubes with hot air or water.
Cursor at channel 5. Display flashes "err" and readings in turn.	Machinery guard	Investigate if the seed-side axle is rotating evenly. If it is, re-program the machinery guard. If it is not rotating, open the gearbox and check its condition.

Normal wear of the seed and fertilizer drill is safe and does not cause hazardous situations.

It must be noted, however, that if the machine is used in violation of traffic and safety regulations or the machine is overloaded and not serviced, there is always the danger of abnormal wear and machine failure, which could result in physical injury or damage to the environment.



## 17 WITHDRAWAL FROM ACTIVE USE

### READ THE SAFETY INSTRUCTIONS



Ending the use of the product is, as a whole, the responsibility of the end user of the product, or the person or company that owns the product when it has reached the end of its life.

For ending the use of the product and the different waste materials created, there are national laws, instructions, and regulations in every user country, which must be followed.

Most parts of the machine are made of non-biodegradable materials, so the machine must be disassembled and the different materials disposed of according to national regulations.

- Iron and other metals are recycled through machine and device stripper bays.
- Waste oil, plastics, and rubber parts other than tires must be treated as hazardous waste and they must be disposed of either by recycling or appropriately transporting them to a landfill or otherwise destroyed according to national regulations.
- Tires must be disposed of according to the directives 83/189EEC, 182/88/EEC, and 94/10/EC by taking the used tires to recycling centres or recycling operators, who send the tires on to be reprocessed.

When needed, further information about disassembling and waste disposal can be obtained from environment authorities.

## 18 TERMS OF GUARANTEE

1. The guarantee period is 12 months in agricultural use in the work the machine is intended for.
2. In municipal, industrial and professional contract work or similar use the guarantee period is 6 months.
3. The guarantee period begins on the delivery date of the new machine from an authorised retailer.
4. The guarantee covers manufacturing and raw material defects. Damaged parts are repaired or replaced with a serviceable part in the factory or in an authorised repair shop. Subcontracted parts have the guarantees of their respective manufacturers.
5. Repairs covered by the guarantee do not extend the guarantee period.
6. The guarantee does not cover damages that are caused by incorrect operation or maintenance carried out against the instructions in the manual, excessive load, or normal wear. The guarantee does not cover secondary damages, out-of-service periods, travel expenses, freight expenses, daily benefit, overtime, or changing the original structure of the machine.

In guarantee matters, please turn to the retailer who will make a guarantee claim. Before any procedures are carried out, they and their possible expenses should be agreed with the manufacturer beforehand.

The guarantee is valid only if the guarantee certificate is returned, appropriately filled in and within 14 days of the delivery date, to the manufacturer.

## 19 SCOPE OF LIABILITY

The manufacturer is not responsible if the seed and fertilizer drill is used against the law, safety regulations or instructions in this manual. In connection with the use of the drill, situations may arise for which there are no instructions or regulations. In these situations the operators are recommended to act according to general machine safety instructions and directives.

Note that the incorrect use of fertilizer and pesticides may cause damage to persons, animals, water systems and soil alike. Follow the instructions given by the manufactures of these substances, and other experts, on how to handle and use them appropriately.

The manufacturer cannot be held liable if the amount of seed, pesticide or fertilizer is incorrect. If you do not have sufficient information based on your own experience, consult an expert.

The manufacturer is also not responsible if the sowing fails. The user must monitor the consumption of the seeds and fertilizer at all times and thus ensure that the amounts in each of the cases remain within the appropriate levels.

The user must also see that the sowing depths are maintained at a correct level by constantly monitoring them.

The manufacturer is not responsible for damages incurred by the usage of other manufacturers' components.

The manufacturer is not responsible for damages incurred to other machines or devices by the use of the seed and fertilizer drill.

The manufacturer reserves the right to develop and change the structure of the machine.

The owner is responsible that all the persons operating the machine with the use and safety instructions of the machine.

USER'S OWN NOTES:

Lined writing area for user's own notes.



**EY -VAATIMUSTENMUKAISUUSVAKUUTUS KONEESTA**

(FI)

Valmistaja Junkkari Oy  
Osoite Pohjanmaanväylä 1720, FIN-62375 YLIHÄRMÄ

Vakuutamme yksinomaan omalla vastuullamme, että markkinoille saatettu kone

**JUNKKARI MAESTRO 3000/4000**

valmistenumeroista **101** alkaen on soveltuvilta osin rakennettu normatiivisien asiakirjojen ohjeiden mukaan ja noudattaa direktiivien 98/37/EY määräyksiä

**EG- FÖRSÄKRAN OM ÖVERENSSTÄMMELSE FÖR MASKINELL UTRUSTNING**

(SE)

Tilverkare Junkkari Oy  
Adress Pohjanmaanväylä 1720, FIN-62375 YLIHÄRMÄ

Försäkrar härmed enbart på vårt eget ansvar, att för marknader tillverkad maskin

**JUNKKARI MAESTRO 3000/4000**

f.o.m tillverkningsnummer **101** är tillverkad i tillämplig mängd i överensstämmelse med instruktioner av det normativa dokumentet följder bestämmelser av följande direktiver: 98/37/EY

**EC DECLARATION OF CONFORMITY FOR MACHINERY**

(EN)

Manufacture Junkkari Oy  
Address Pohjanmaanväylä 1720, FIN-62375 YLIHÄRMÄ

Herewith declare on our sole responsibility that for the market produced machine

**JUNKKARI MAESTRO 3000/4000**

from the manufacturing number **101** is manufactured, where applicable, in conformity with provisions of the instructions of the normative document according to the following directive: 98/37/EY

**DECLARATION CE DE CONFORMITE POUR LES MACHINES**

(FR)

Fabricant Junkkari Oy  
Adresse Pohjanmaanväylä 1720, FIN-62375 YLIHÄRMÄ

Certifions á nos propres risques, que la machine suivante commercialisée

**JUNKKARI MAESTRO 3000/4000**

et ce depuis le numéro de série **101** est en conformité avec les normes applicables et les dispositions de la directive 98/37/EY

**EG-KONFORMITÄTSEKTLÄRUNG FÜR MASCHINEN**

(DE)

Hersteller Junkkari Oy  
Adresse Pohjanmaanväylä 1720, FIN-62375 YLIHÄRMÄ

Erklären hiermit ausschließlic auf eigene Verantwortung, daß die Maschine

**JUNKKARI MAESTRO 3000/4000**

von der Herstellungsnummer **101** konform mit den einschlägigen Bestimmungen von dem normativen Document hergestellt ist und Bestimmungen von Direktiven: 98/37/EU

**EC SAMSVÆRSERKLÆRING OM MASKINER**

(NO)

Produsent Junkkari Oy  
Adresse Pohjanmaanväylä 1720, FIN-62375 YLIHÄRMÄ

Erkærer at produktet beskrevet heretter

**JUNKKARI MAESTRO 3000/4000**

f.o.m Tillverkningsnummer **101** Som omfattes av denne erklæringen, er i samsvar med instruksjonene i dokument samt bestemmelsene i følgende direktiv: 98/37/EY.

<b>TOEND MASINA NOUTELEVASTAVUSE KOHTA (EE)</b>	
Valmistaja Address:	Junkkari Oy Pohjanmaanväylä 1720, FIN-62375 YLIHÄRMÄ
Kinnitamme ainuüksi omaenda vastutus el, et turule lastud masin	
<b>JUNKKARI MAESTRO 3000/4000</b> valmistusnumbrid <b>101</b> on ehitatud normatiivsete dokumentide juhiste kohaselt ja vastab direktiivi 98/37/EY nõustele	

<b>ZAPEWNIENIE ZGODNOSCI URZADZENIA Z WYMAGANIAMI</b>		<b>(PO)</b>
Producent Adres	Junkkari Oy Pohjanmaanväylä 1720, FIN-62375 YLIHÄRMÄ	
Zapewniamy wyłacznie na własna odpowiedzialność, że wprowadzona do sprzedaży		
<b>JUNKKARI MAESTRO 3000/4000</b> począwszy od nr fabrycznego <b>101</b> jest skonstruowana w zakresie stosowalności zgodnie z normatywną dokumentacją i przepisami dyrektywy: 98/37/EY		

<b>CEE DECLARACIÓN DE CONFORMIDAD PARA MAQUINARIA</b>		<b>(ES)</b>
Fabricante: Dirección:	Junkkari Oy Pohjanmaanväylä 1720, FIN-62375 YLIHÄRMÄ	
Declara en su misma responsabilidad que la máquina construida modelo:		
<b>JUNKKARI MAESTRO 3000/4000</b> con el numero de fabricación 101 está fabricada con conformidad a las prescripciones de la normativa referente a la siguiente directiva: 98/37/EY		

Ylihärmässä 1.12.2008



Arto Aro  
Tekninen Johtaja  
Technical Director