

# Junkkari

## SIMULTA 3000 T/ST

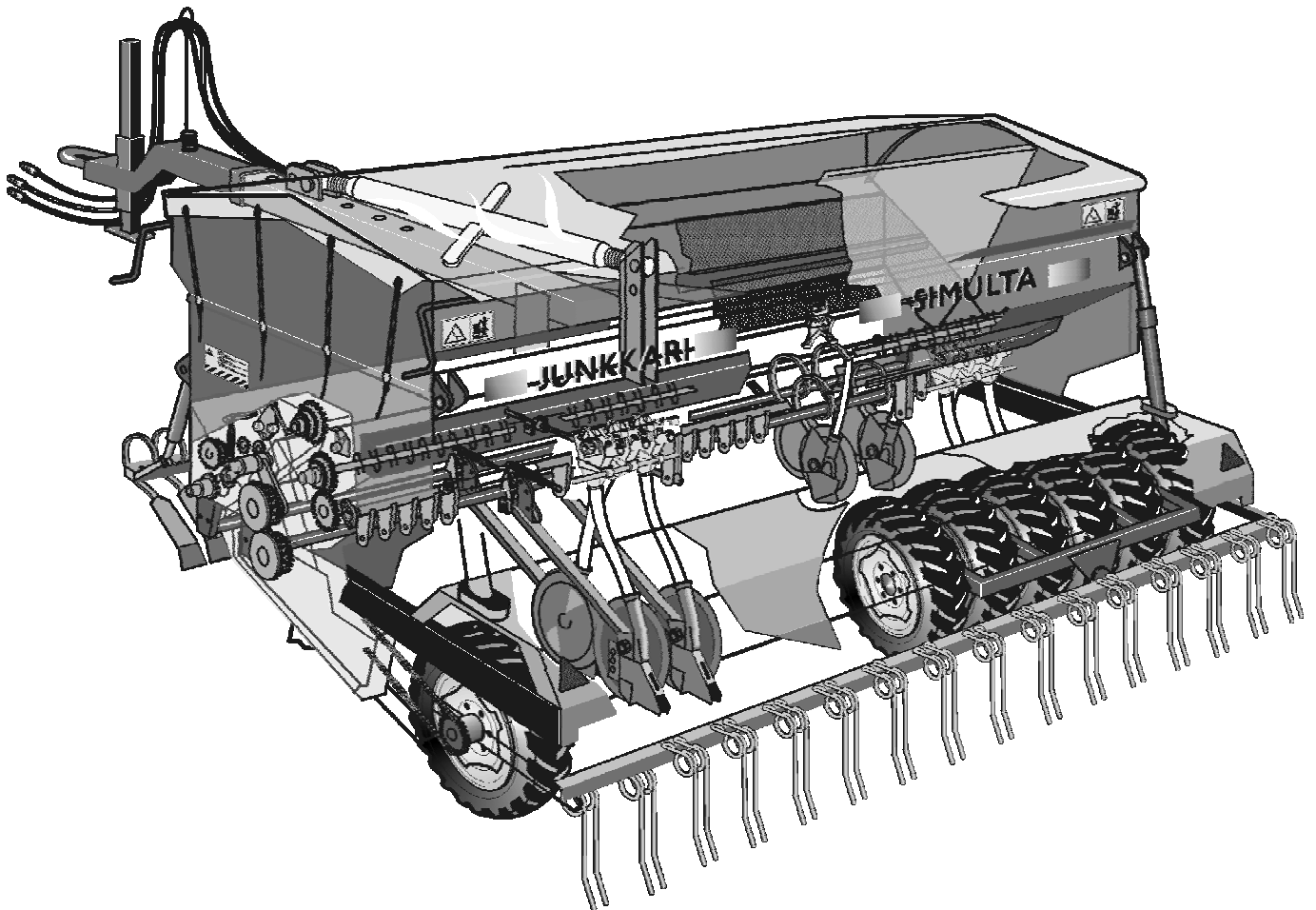

### OPERATOR'S MANUAL SPARE PARTS CATALOGUE

Junkkari Oy  
62375 YLIHÄRMÄ FINLAND  
TEL. +358-(0)6-4835111  
Fax: +358-(0)6-4843295  
e-mail: [junkkari@msk.fi](mailto:junkkari@msk.fi)  
Internet: [www.junkkari.fi](http://www.junkkari.fi)

ST09ENG

ENGLISH 

# 1 CONTENTS

	PAGE
2. FOR THE READER.....	3
3. TECHNICAL DATA.....	3
4. SAFETY INSTRUCTIONS.....	4
4.1 GENERAL SAFETY INSTRUCTIONS.....	4
4.2 TRANSPORTING AND MOVING THE MACHINE.....	4
4.3 MAINTENANCE AND REPAIRS.....	5
4.4 HYDRAULICS.....	5
4.5 CLEANING THE MACHINE.....	5
5. WARNING LABELS, SAFETY COMPONENTS AND SERIAL NUMBER PLATE.....	6
6. OPERATING ENVIRONMENT.....	8
6.1 OBJECTIVE OF DESIGN.....	8
6.2 OPERATIONAL LIMITATIONS AND FORBIDDEN FORMS OF USE.....	8
7. PRINCIPLE OF OPERATION.....	8
8. TRANSPORTATION, HANDLING AND STORAGE.....	9
8.1 TRANSPORTATION.....	9
8.2 HANDLING.....	9
8.3 STORAGE.....	9
8.4 SPECIAL SAFETY NOTES ON MACHINE TRANSPORTATION.....	9
9. TAKING THE MACHINE INTO USE.....	10
9.1 DELIVERY PACKAGE.....	10
9.2 REMOVAL OF TRANSPORTATION SUPPORTS AND PREPARING THE MACHINE FOR USE.....	11
9.3 PLACING THE LIFT SENSORS FOR THE WIZARD ON-BOARD COMPUTER ON THE DRILL....	12
9.4 ATTACHING TO A TRACTOR.....	13
9.5 ASSEMBLY AND MOUNTING.....	14
9.6 DISPOSAL THE PACKAGING MATERIALS.....	19
9.7 BALANCE WEIGHTS.....	19
10. ACCESSORIES.....	20
10.1 SEED COULTERS.....	20
10.2 FERTILIZER COULTERS .....	20
10.3 ON-BOARD COMPUTER.....	20
10.4 FEED MECHANISM.....	21
10.5 REAR HARROW .....	21
10.6 FRONT FIELD DRAG.....	21
11. OPTIONAL EQUIPMENT.....	21
12. OPERATION AND CONTROL OF THE DRILL.....	23
12.1 ADJUSTMENTS BEFORE A SOWING RUN.....	23
12.1.1 WORKING POSITION.....	23
12.1.2 FERTILIZER COULTER ADJUSTMENT.....	23
12.1.3 SEED COULTER ADJUSTMENT.....	23
12.1.4 HUB COUPLING.....	24
12.1.5 CHOOSING FEED RATES AND CALIBRATION TEST.....	24
12.1.6 SOWING CHART.....	28
12.1.7 CALIBRATION TEST ADJUSTMENTS.....	29
12.2 USER GUIDE FOR THE ON-BOARD COMPUTER JUNKKARI WIZARD.....	31
12.3 SOWING.....	52
13. MAINTENANCE.....	53
13.1 LUBRICATION.....	53
13.2 CLEANING AND STORAGE DURING SEASON.....	53
13.3 D.I.Y. REPAIRS.....	53
13.4 WIRING DIAGRAMS.....	55
14. LUBRICATION CHART.....	58
15. CLEANING AND STORAGE.....	60
15.1 CLEANING.....	60
15.2 STORAGE.....	60
16. TROUBLESHOOTING CHART.....	61
17. WITHDRAWAL FROM ACTIVE USE.....	63
18. TERMS OF WARRANTY.....	64
19. SCOPE OF LIABILITY.....	64
PERSONAL NOTES.....	65
EC DECLARATION OF CONFORMITY.....	66
SPARE PARTS CATALOGUE.....	V1-V56

## 2 FOR THE READER

We wish you every success in your work.

We would ask you to read through the instructions contained in this manual and acquaint yourself with your machine, its principles of operation and the maintenance schedules all points which will affect operational safety and uninterrupted operation during the busy sowing seasons.

It is imperative that every section of this manual is fully understood and that the instructions regarding the machine's operation are followed. In unclear cases, please contact your Dealer.

We also hope that you will kindly return the Certificate of Warranty after having acquainted yourself with the instructions of this manual.



### WARNING SYMBOL

In the manual, this symbol is used to indicate danger to the operator or other people close to the machine.

In addition, the symbol is used when there is a risk to the environment or property.

## 3 TECHNICAL DATA

	S2500 T	S3000 T	S3000 ST	S4000 ST
Working width, cm	250	300	300	400
Row spacing cm				
- seed	12.5	12.5	12.5	12.5
- fertilizer	25	25	25	25
Hopper capacity				
- seed maximum	1320	1584	3390	4528
- fertilizer minimum	920	1104	0	0
- seed minimum	890	1068	1593	2124
- fertilizer maximum	1360	1640	2580	3440
Filling height, cm	150	150	175	175
Tyres	7.00-12" 6ply	7.00-12" 6ply	7.50-16" 6ply	7.50-16" 6ply
Weight, unloaded, kg	1800	2200	3000	3600
Overall width, cm	284	334	334	434

### STANDARD EQUIPMENT

-Electronic areal meter and hopper level alarm sensors	*	*	*	*
-Computer controlled tramlining			*	*
-Fertilizer sieve	*	*	*	*
-Foot board	*	*	*	*
-Automatic rear harrow	*	*	*	*
-Lighting equipment	*	*	*	*
-Front end field drag			*	*

### OPTIONAL EQUIPMENT

-Small seed box/start-up fertilizer Rationing unit	*	*	*	*
-Row markers	*	*	*	*
-Disinfectant treatment unit	*	*	*	*
-Remote control unit (fertilizer)	*	*	*	*
-Tramline marker (computer oper.)	*	*	*	*
-On-board computer (Artemis)	*	*	*	*
-Drawbar for power harrow	*	*	*	
-Wheel track eradicators	*	*		
-Front end field drag	*	*		
-Front leveler	*	*	*	*
-Intermediate packer	*	*	*	*
-Front lifting cylinder	*	*	*	*
-Sieves for the seed hopper	*	*	*	*

**SPARE PARTS:** When ordering spare parts always specify the machine model and the year of manufacture and also both the description and the part no. Of each part required.

## 4 SAFETY INSTRUCTIONS

### 4.1 GENERAL SAFETY INSTRUCTIONS

- CLOTHING: Always use well-fitting clothing for the sake of safety during operation of the machine.
- OPERATION: Acquaint yourself fully with the attachment, controls and operational principles of the machine before starting to operate it.
- WARNING LABELS: Always comply with all warning labels attached to the machine at various points.
- SHIELDS: The machine must have all its shields and covers in place before you attempt to operate it.
- ATTACHMENT TO TRACTOR: Exercise special caution when attaching the implement to or when detaching it from the tractor.
- HITCH LOAD: Always note the maximum load limits on the draw bar or on the tractor hitch.
- SUPPORT BRACKET: There is a danger of crushing when installing the support bracket.
- PARKING: Ensure that the machine cannot move while parked.
- SAFETY DISTANCE: The machine employs certain components which, due to the nature of the machine's operation, cannot be fully shielded. A safe distance from these working parts must always be maintained. The operator must also take care that no outside person(s) can approach these components during the machine's operation.
- OPERATION: No outsiders must be allowed to be near or on top of the machine while it is running.
  - Never go into the space between the machine and the tractor when the machine is either being lifted up, lowered down or being transported around.
  - Never bend under or lean over the top of a machine which is being supported above the ground by tractor hydraulics only.
  - Ensure each time before taking the machine into use that it has been correctly attached to the tractor and that all its protective shields are in place.
  - Before starting to move the machine, always check that all outside persons are within a safe distance away from it.
  - Inspect the machine after each operating run, especially its hitching and other connection points.
  - In case the machine is fitted with disinfectant treatment applicator, ensure that the instructions given by the manufacturer of the disinfectant are followed throughout the operation.
  - Extra seed or fertilizer must not be carried on top of the machine covers or on the foot board.
  - Never overload the drill. Acquaint yourself with partial emptying techniques of large bulk sacks.
  - Be careful not to damage the covers with freely swinging large bulk sacks while lifting them.

### 4.2 TRANSPORTING AND MOVING THE MACHINE

- The maximum towing speed for the drill is 30 kph (18.7 mph).
- Always comply with the traffic laws while transporting a towed machine on public roads.
- Check and install all necessary equipment required for transporting on public roads, such as lights, reflectors and the warning triangle denoting a slow moving vehicle.
- Check the allowed axle loads, total loads and the overall transport dimensions.
- All equipment coupling the tractor and implement together for transportation of the latter, e.g. chains, draw bars etc., must be installed in such a manner that no unintentional movements cannot affect their positions or functions either during transport or in operating positions.
- Towed or mounted implements and extra weight on the tractor can influence its behavior during transportation, especially its steerability and brakeability. It is therefore important that both steerability and brakeability be retained at all times.
- No passengers may ride on the machine.
- The machine must be lifted only from lifting points marked by the labels on the machine.
- Use only approved lifting slings and chains for lifting, and check their condition before attempting a lift.
- If the machine is transported, for example, on a platform, ensure that it is securely fastened down using, for example, suitable straps, slings or chains.

- If a forklift truck is used to lift the machine, take every precaution to keep the machine balanced on the lifting forks and ensure that there is no danger of the machine falling down.
- Always make sure that the pulling device peg is fitted in place and secured with a pin.

### 4.3 MAINTENANCE AND REPAIRS

- Before attempting any cleaning, lubrication, fitting or adjustment of the machine, always make sure first that the tractor hydraulics are disengaged and the tractor engine switched off. Remove the tractor ignition key from the starter switch to prevent any unintentional starting of the tractor or the implement.
- Always support the implement adequately before starting any maintenance work on it.

### 4.4 HYDRAULICS

- The maximum pressure in the hydraulic system is 210 bar.
- High pressure is induced into the machine's hydraulic system after it is coupled to the tractor system. A jet of high-pressure hydraulic oil penetrates skin and causes grave injury. A danger of injury exists even when looking for oil leaks.
- Handle oil hydraulic components and parts with extreme care. The nature of the equipment will always present a danger of cuts or crushing action.
- The hydraulic couplings must not be detached while the machine is supported by hydraulics only, because that way the system will be left pressurized.
- When connecting the machine's hydraulic system to the tractor system, both systems must be unpressurized.

### PROTECTIVE MEASURES AGAINST OILS AND GREASES

- Always use suitable protective clothing and oil-proof gloves when handling oil or grease.
- Avoid direct skin contact with oil or grease, as these may cause skin injury.
- Never use oil or grease to clean off dirt from skin. These substances may contain tiny metal particles which can cause cuts in the skin, further aggravated by the action of the oil.
- Follow the handling and safety instructions given by the manufacturers of the lubricants.
- Many synthetic oils are corrosive and cause severe irritation of the skin.

#### WASTE OIL

- Waste oil must be collected into a suitable container and taken to a collection center for proper disposal compliant with national regulations.

#### ACCIDENTS

- If oil is spilled on the ground, it must be prevented from spreading and the oil must be collected by absorption, for example, into peat.
- Should oil or grease cause a skin injury contact the nearest physician at once.

### 4.5 CLEANING THE MACHINE

- The seed and fertilizer drill must always be cleaned before changing to another type of seed or fertilizer.
- In case the machine is stored over night or a long period of rain, the fertilizer hopper has to be emptied and feeding rolls must be cleaned from any residual material by moving the feed rate adjustment from one extreme position to the other.
- Do not spray water to electric parts.
- If any detergent is used, always ensure its suitability and follow manufacturers instructions.



NOTE: THE MACHINE IS INTENDED TO BE OPERATED BY A SKILLED FARMER, THEREFORE ITS USE REQUIRES ADEQUATE GENERAL KNOWLEDGE AND SKILLS OF AGRICULTURAL PRACTICES. USE LARGE HOPPER VOLUMES THOUGHTFULLY. ALWAYS CONSIDER OPERATING WITH PARTLY FILLED HOPPERS IN EXTREMELY DAMP CONDITIONS.



# 5 WARNING LABELS, SAFETY COMPONENTS AND SERIAL NUMBER PLATE



LIFTING POINT

### SERIAL NUMBER PLATE

1. Year of attachment of the CE-plate
2. Machine model
3. Serial number and year model
4. Machine weight w/o accessories
5. Manufacturer



NO PASSENGERS ALLOWED



DANGER OF CRUSHING



**HUOM. / OBS. / NOTE**  
Kiristä pultit 3 tunnin ajon jälkeen.  
Spänn bultarna efter 3 timmar körning.  
Tighten bolts after first 3 hours of running.

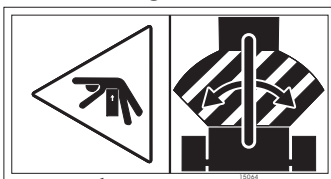

DANGER OF BEING CRUSHED BETWEEN THE IMPLEMENT AND TRACTOR



DO NOT GO UNDER MACHINE



Lue käyttö- ja turvallisuusohjeet aina ennen käyttöönottoa.  
Läs bruksanvisning och säkerhetsföreskrifter innan den nya maskinen tas i bruk.  
Become familiar with the owners manual and safety instructions before starting to operate this machine.

4-32173

## REFLECTORS AND WARNING STRIPES

Towed implements must be fitted with triangular, E-approved red reflectors at the rear end. (Fig. 3)

At the front the reflectors should be white in colour and the shape may not be triangular.

At the machine sides there should be yellow, E-approved, rectangular reflectors. The required amount of side reflectors depends on the length of the implement. (Fig. 4)

Towed machines must always be equipped with a slow moving vehicle warning triangle. (Fig. 2)

The implement sides must be fitted with red and yellow warning stripes, visible from the front and the rear of the machine. (Fig. 1)

This equipment is factory fitted to the basic machine body, or alternatively, at rear end of the optional small seed box. (Fig. 5)



Fig.1

## LIGHTING EQUIPMENT

The Simulta drills come equipped with lighting equipment required by the road safety regulations.

Lighting equipment is attached to the machine body in basic Simulta T- and ST-models. (Fig. 3) In case the machine is fitted with the optional small seed box, the lighting equipment must be attached to that. (Fig. 5)

The wiring connectors can only be connected in one way, so that no problems will arise, for example, when connecting the turning signals. The wiring is fixed to the frame with plastic ties provided in the package.

The lighting harness is connected to the tractor's electrical outlet by a standard 7-pin socket connector.



Fig.2

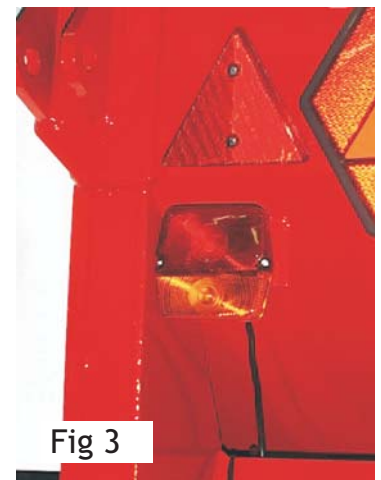

Fig 3



Fig. 4



Fig. 5

## 6 OPERATING ENVIRONMENT

### 6.1 OBJECTIVE OF DESIGN

The Simulta seed and fertilizer drill has been designed for simultaneous drilling of both seed and granulated fertilizer.

The Simulta drill prepares the seed bed, places the fertilizer in a beneficial position to the seed, sows the seed with row spacing of 12.5 cm and finally packs the soil on top of the seed.

With multiple selection of accessories and optional equipment available, the Simulta drill can be equipped to fit every special need and every farm.

The basic equipped Simulta drill is ready for sowing cultivated soil as it is. By using the available accessories and optional equipment the machine features can be altered to fit several different operational conditions and practices.

Each attachment and its appropriate use is introduced individually for each item later in this manual.

### 6.2 OPERATIONAL LIMITATIONS AND FORBIDDEN FORMS OF USE



Limitations regarding the operator

- The operator of the machine may not be under the influence of narcotic substances, alcohol or strong medication.
- In case of illness or disability, the attending physician can give the permission to operate the machine. Use of the machine is forbidden from people without the appropriate knowledge and skills in farming, and from children under 15 years of age.

Environmental limitations

- Avoid using the machine in extremely damp or very dry conditions where the proper moisture level for the seeds can not be confirmed.

Forbidden forms of use

- The machine may not be used in a water protection zone, or on other areas designated for nature conservation.
- It is forbidden to spread liquids, flammable substances, sand, or powdery or fibrous substances with the machine.

## 7 PRINCIPLE OF OPERATION

The Junkkari Simulta seed and fertilizer drill has an accurate, grooved push feeder mechanism, where the feed rate is adjusted by altering the effective length of the grooved rollers, by the adjustment wheels on the right side of the machine or by a remote control unit which is available as an optional equipment. The feed mechanism is driven by the left side support wheels. The power is transmitted to the feed mechanism by a chain gearing. The seeds and the fertilizer granulates flow through feed pipes down to the coulters which plant them to the set depth in the ground. The drag, which is basic equipment in the STmodels, levels the seed bed and forms an optimal soil surface crumb size for ideal drilling conditions. The drag is available for Tmodels as an optional equipment. The working depth of the seed coulters can be adjusted either individually or by a central adjustment system. The working depth of fertilizer coulters is adjusted by altering the machines operating height. The support wheels serve also as packing roller wheels in T and ST models. The spiked wheel pattern prevents the soil from crusting. There is, as basic equipment, in both T and ST models, a rear harrow which spreads a layer of loose soil on top of the seed to prevent the ground moisture from rising to the surface and being evaporated by the sun.



## 8 MACHINE TRANSPORTATION, HANDLING AND STORAGE

(IMPORTER, DISTRIBUTOR, DEALER)

### 8.1 TRANSPORTATION

- The terms of delivery of the product are ex works, unless specified otherwise.
- The buyer (importer) and the factory agree upon a date of the delivery when the product is ready for shipment.
- The factory will arrange the loading of the product on a transport vehicle at the factory premises.
- The transport agency is responsible for the product for the period of transportation from the factory to the buyer.

### 8.2 HANDLING

- The product must be handled in the careful manner which is customary in handling all agricultural machinery, without causing any damage to the product.
- No other products may be loaded on top of the machine package.
- The factory packs the product carefully for shipment.
- The transportation attachments must remain attached during the handling of the product.

### 8.3 STORAGE

- The machine must be shielded from direct sunlight and rain and stored in its wheels with coulters lifted from the ground.
- When stored outdoors, check periodically that there is no water or snow left standing either on top or inside the machine.
- The machine must always be stored indoors for any long-term storage periods.

### 8.4 SPECIAL SAFETY NOTES ON MACHINE TRANSPORTATION



- Never attempt to lift the machine from any other point than those clearly marked for lifting. (Inside the machine, on the separation wall).
- Check before lifting that the transportation securing pins are attached.
- Ensure that the lifting device is adequately efficient and safe and that no there exists no danger of the machine overturning or falling down.
- The machine must never lifted on forklifts, but solely by flexible slings or chains.
- Always use only approved slings or chains for lifting.
- Always check the condition of the slings and chains before lifting.
- T and ST model drills must never be tipped over to rest on their noses.
- Always check the lift/reach capacity of the lifting device.
- The machine must always be kept securely tied down to the platform during transportation.
- When lifting the machine take care of the danger of swaying. Avoid all sudden movements.
- It is imperative to remove the transport securing pins before connecting the machine's hydraulic system to that of a tractor.

## 9 TAKING THE MACHINE INTO USE

Unless otherwise specified, the customer is responsible for other preparations necessary to bring the machine into an operative condition. If the product be transported in a container, the importer or its representative is responsible for bringing the machine up to standard condition before it is delivered to the customer.

The customer shall also attend to the assembly of any optional equipment unless otherwise specified. The optional equipment can be factory-assembled with the assembly costs added to the price of the option in question.

### 9.1 DELIVERY PACKAGE

#### T MODELS

The machine with all its equipment is packed in a single package for a standard delivery. The machine is packed inside protective plastic sheeting and the following parts are included in the package:

- Operator's manual.
- Fertilizer sieves (4 off) inside the fertilizer hopper.
- Lighting equipment ready-mounted on the machine.
- Calibration test handle at its place under the fertilizer hopper.
- Slow Moving Vehicle warning triangle inside the fertilizer hopper.
- Drawbar ass'y attached to the foot board.
- Top link inside the fertilizer hopper.
- Top link attachment pins and linchpins used as transport pins in the leveling box.
- Areal meter display unit inside the fertilizer hopper.
- Rear harrow frame attached to foot board cover, harrow lift springs tied down in their positions, harrow arms complete with adjusting screws inside the fertilizer hopper and mounting bolts screwed down into the machine's arm.
- Front hand-grips attached on the inside of the fertilizer hopper.
- Hitch and its attaching linchpin on top of the foot board.
- Hopper canvas cover in package on top of the foot board.
- Support for the hydraulic hoses inside the fertilizer hopper.
- Support leg ready-mounted on the machine.

#### ST MODELS

The machine with all its equipment is packed in a single package for a standard delivery. The machine is packed inside protective plastic sheeting and the following parts are included in the package:

- Operator's manual.
- Fertilizer sieves (4 off) inside the fertilizer hopper.
- Lighting equipment ready-mounted on the machine.
- Calibration test handle on its place under the fertilizer hopper.
- Slow Moving Vehicle warning triangle inside the fertilizer hopper.
- Drawbar ass'y attached to the foot board.
- Top link inside the fertilizer hopper.
- Top link attachment pins and linchpins used as transport pins in the leveling box.
- Areal meter display unit inside the fertilizer hopper.
- Rear harrow frame attached to foot board cover, harrow lift springs tied down in their positions, harrow arms complete with adjusting screws inside the fertilizer hopper and mounting bolts screwed down into the machine's arm.
- Hopper canvas cover in package at its place on top of the machine.
- Support for the hydraulic hoses inside the fertilizer hopper.
- Support leg inside the fertilizer hopper.
- Front leveler ass'y with its mounting accessories tied down on the foot board, hydraulic equipment ready-mounted on the machine.

## 9.2 REMOVAL OF TRANSPORTATION SUPPORTS AND PREPARING THE MACHINE FOR USE



1. Detach the linchpins and remove transportation supports from between cylinder brackets and foot step frame.

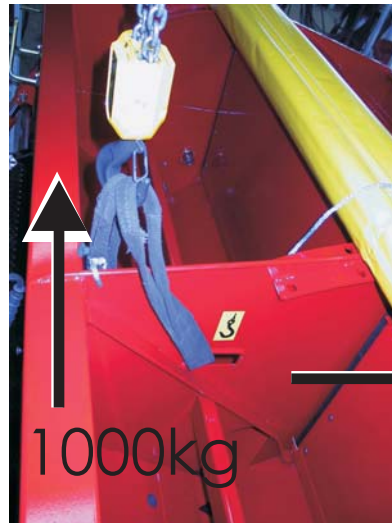

2. The machine must only be lifted from points marked for lifting. To lift the machine requires lifting capacity of 1000 kg.

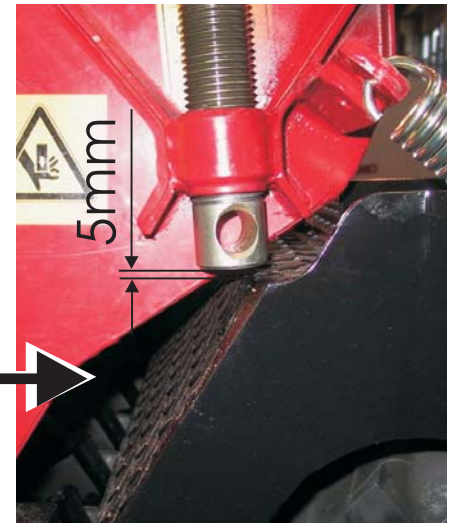

3. Lift the machine just enough to raise the height adjusting screw, which serves as a transport support, from its base. 5 mm is enough.



4. Remove the upper transport attachment screw from the arm to let the arm turn pivoted on the lower screw. Then the wheel assembly is also able to move to its place behind the machine.



5. and 6. Support the arm with, for example, a jack, while turning it, to help locating the attachment screw holes (4 pcs). Required lifting power is 50 kg. The height adjustment screw will also take its place when the arm turns.



7. Tighten the arm attachment screws with care (4 pcs/side).

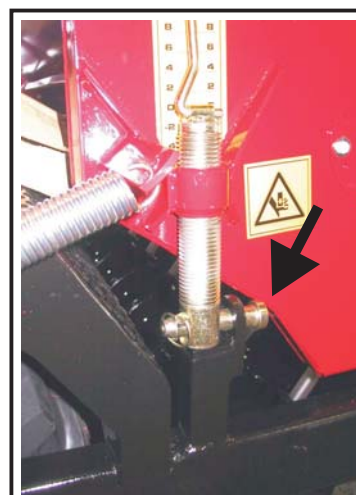

8. The transport pegs and pins must be removed before engaging the machine to hydraulic system. The top link attachment pegs and pins serve as transport pegs for the height adjustment screw.





9. Placement of the calibration test lever (in front of the machine, under the fertilizer hopper).

### 9.3 PLACING THE LIFT SENSORS FOR THE WIZARD ON-BOARD COMPUTER ON THE DRILL

Acquaint yourself carefully with the instructions for the Wizard multi-function drill control drive computer. All sensors and magnets in relation to the Wizard's functions are installed at the factory to all new Simulta drills.



1. The sensor of lifting and lowering of the drill is placed to the right side of the machine, at the end of the bogie arm.

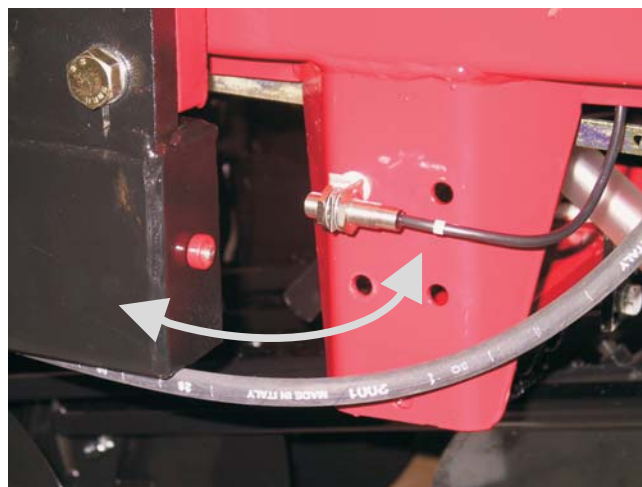

2. The seed and fertilizer drill at the position for drilling. The sensor will recognize the magnet and give an impulse to the Wizard, when the machine is either lifted or lowered.

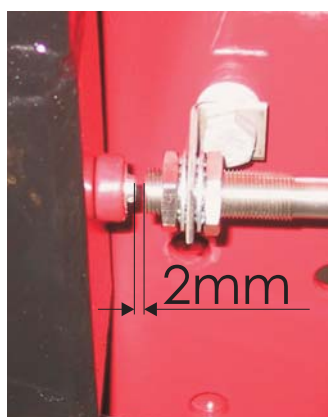

3. The seed and fertilizer drill lifted to the top position. The sensor is placed and adjusted at the top position of the machine to almost touch the magnet. An adequate clearance would be c.a. 2 mm.



## 9.4 ATTACHMENT TO A TRACTOR

### READ THE SAFETY INSTRUCTIONS FIRST



The tractor HITCH MOUNTED T model three-point linkage is attached to the tractor lower links (ISO Standard 730, category 2). If the lowering rate of the tractor lift linkage is adjustable, the speed rate control lever should be moved to position SLOW.

IF THE TRACTOR IS EQUIPPED WITH A WEIGHT-TRANSFER SYSTEM, IT MUST BE KEPT IN OFF-POSITION THROUGHOUT ANY SOWING OPERATION.



ST models are coupled into the tractor's rear towing hook (ISO 6489/1) or to an optional roller attachment, which in turn is attached to the tractor lower links.

2500T-, 3000T-, 3000ST- models can also be attached to a power harrow attachment by means of an optional power harrow hitch. In this case the T models must be equipped with a draw bar arrangement similar to that used in the ST model. The 4000ST drill, however, is not recommended to be used with a power harrow, due to the sheer size of this model.

#### HYDRAULICS

The Simulta T and ST drills require one external, single-acting hydraulic control valve for lifting the machine. An additional double-acting valve section is required if a front end field drag is used. The drill can also be equipped with an optional hydraulic row marker. The row markers' controls and operations are handled from the tractor cabin by using the Wizard on-board computer. The row markers are coupled to the drill's hydraulics with a factory-assembled female bayonet in the drill lifting system hydraulic line.

The quick-release couplings (bayonets) are compliant with ISO 7241-1 standard.

#### ELECTRICAL CONNECTIONS

The lighting equipment is connected to the tractor's 7-pin electrical socket connector compliant with the SFS 2472 / DIN ISO 3732 standards.

The Wizard multi-function drill control on-board computer, which is basic equipment of the drill, is connected with connectors compliant with ISO/TR 12369 standard.

The nominal voltage used is 12V DC. The connecting procedures are dealt with in later chapters of this manual related to each separate piece of equipment.

Other electrical optional equipment for the machine is also available and these use the DIN ISO 4165 or ISO/TR 12369 standard connectors for their connection to the machine's electrical system.

#### CABLE CONNECTION

If the machine is equipped with a cable-operated remote control, the cable is attached to a suitable location in the tractor by means of a mounting support, delivered within the package. The location of the remote control should preferably be in the vicinity of other tractor controls so as to provide for best ergonomic conditions.

## 9.5 ASSEMBLY AND MOUNTING INSTRUCTIONS

1. Remove the protective plastic sheeting and the metallic and plastic tie-taps.
2. Remove the transportation securing pins (see Fig. 1).
3. Inspect the contents of the delivery package.

**NOTE! REMEMBER TO CHECK THE POSITION OF THE HUB COUPLING (SEE SECTION 12.1.4).**

### ATTACHING AND ADJUSTING THE REAR-MOUNTED HARROW ATTACHMENT

The rear harrow is mounted on the supports provided on either side of the bogie frame with M16 bolts and self-locking nuts. Tighten the nuts loosely to enable the harrow to move freely. The harrow lift springs are attached to the lift chains so that an equal amount of free links are left on each chain (refer to Figs. 2 and 3).

The harrow operating angle can be adjusted to suit prevailing conditions. The harrow support arms have 3 mounting holes each to provide three operating heights for the harrow frame. This is necessary to limit the height of the lowermost operating position. It is also needed to enable the harrow arm to make contact with a stopper in the machine's frame, when stepping on the foot board on the harrow frame. The adjusting screws for altering the harrow's angle of advance must be tightened down properly ('A' in Figs. 4 and 5).

The adjustments to the harrow are best done on the field, right after the sowing adjustments. The principle used is that the harrow follows the machine smoothly spreading the loose soil left between the tyres over the hard-packed tread marks. The loose soil layer prevents the humidity in the soil from rising to the top through the action of capillary flow and evaporating away. The optimum working depth for the harrow is about 2 cm (3/4") below the mean ground level of the field but is always, however, kept above the seed bed level.

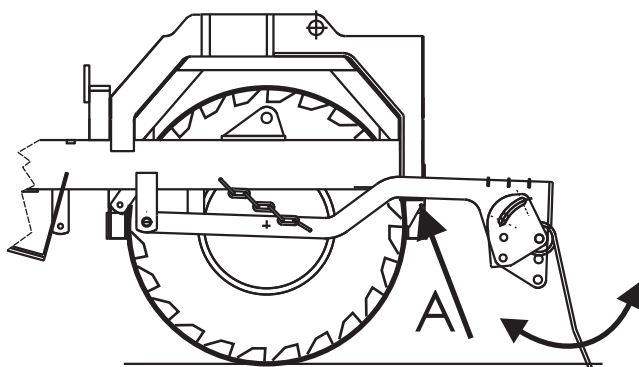
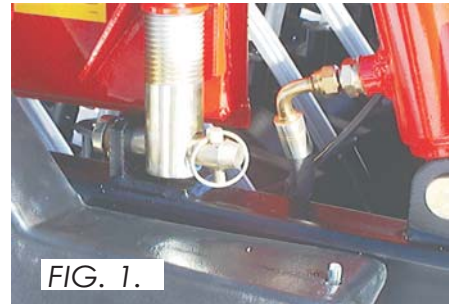

FIG. 4.

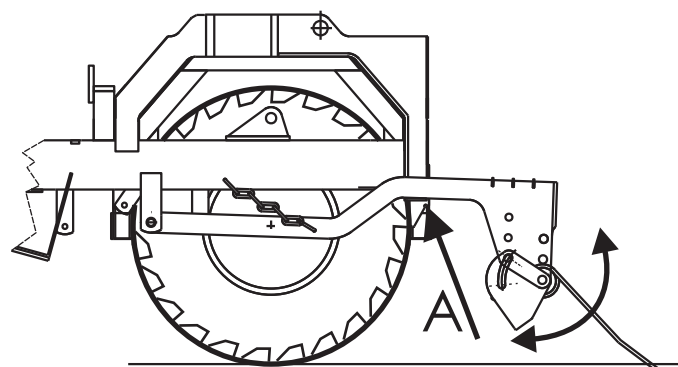

FIG. 5

## ATTACHING THE LIGHTING ACCESSORIES

The lighting equipment has been ready-mounted on the machine at the factory. If you fit a T model drill with a small seed box attachment, the lighting accessories and reflectors must be relocated in the mounting points provided at the rear of the box attachment (refer to Figs. 6 and 7).

FIG. 6



FIG. 7



## MOUNTING THE HOPPER CANVAS COVER (T MODELS)

The shape of the hopper canvas cover is designed to cover the optional small seed box, if that is fitted. If the small seed box is not fitted, the extra portion of the covering canvas is kept rolled around one of the carrier rolls so that the canvas is kept symmetrical in relation to the centre roll. The canvas can thus be attached to the hopper in either way.

If you attach the small seed box, you must attach the canvas on top of the hopper with its longer end pointing rearwards to enable the canvas to cover the box as well.

### Mounting on a basic mode

L

- The canvas cover is attached to the mounting holes at each end of the hopper by the centre canvas roll with the screws provided in the roll (refer to the illustrations below).
- The canvas is then ready to be spread over the hopper.

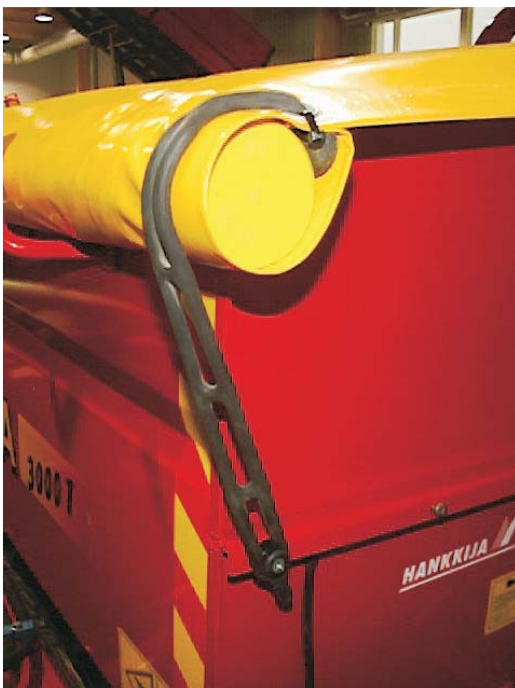



### Mounting on a basic model with small seed box:

- Free a part of the canvas, wrapped for only one round around one of the carrier rolls, by removing its plastic tie-strap and adhesive strip. Refit the rubber fastener to the outermost reinforcing ring in the canvas.
- Attach the canvas with the longer canvas half facing rearwards.
- (- Refer to the illustration on the right.)



### Using the canvas hopper cover

In normal use, with the centre roll attached to the machine with screws, the canvas is rolled to the hopper centre to uncover both hopper sections.

The whole canvas cover may also be rolled to rest at the front of the hopper. In this usage, you must remove the centre roll screws to free the centre roll and you must attach the front rubber fasteners to the attaching mountings provided at the centre of the hopper (refer to illustrations on the right.)



### MOUNTING THE HOPPER CANVAS COVER (ST MODELS)

The canvas hopper cover is ready-mounted at the factory. The canvas cover has a string on both sides of it to be used to alter the place where the cover is rolled to, either to the front, the rear or in a desired point at the hopper, by adjusting the length of the string.

There is a part of the canvas cover separated with an adhesive strip from the rest of the cover, to be used in case the small seed box is assembled to the machine.

### ATTACHING THE SLOW MOVING VEHICLE (SMV) WARNING TRIANGLE

Mount the SMV warning triangle supplied with the machine package at the rear of the machine with the adhesive strips on the back side of the triangle. The mounting surface must be clean to enable a lasting bond. Remove the protective covering from the adhesive strips and press the triangle against the hopper rear side plating. Do not touch the adhesive strips to keep the adhesive clean and to retain its adhesive properties. The triangle must be mounted at the far left of the rear end of the machine. Note that if the machine is equipped with a small seed box, the triangle must be mounted at the rear end of the box (refer to Figs. 1 and 2).

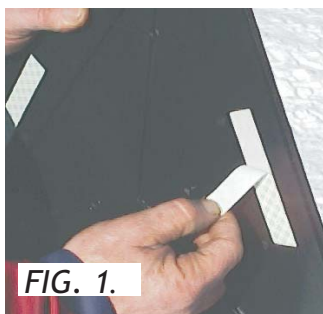

FIG. 1.



FIG. 2.



## SUPPORT LEG AND HITCH ATTACHMENT

The drawbar ass'y consists of a drawbar frame, drawbar, hydraulic hose support and top link ass'y. Attach the drawbar frame to the machine with the attaching pins supplied. Attach the top link with pins, which are mounted for the duration of transport to the bogie frame to act as securing pins for transport position. Insert the drawbar into the frame and attach it with a pin securing the drawbar and its frame to each other. The T models are also supplied with a three-point lateral drawbar, which is attached to the tractor links in the normal manner. In this case it is recommended to use the shortest possible drawbar length adjustment.

The ST models cannot be connected to a 3-point drawbar because of the front field drag. These models are supplied without the 3-point drawbar.

Fix the drawbar to the upper holes in the mounting brackets of the drill (Fig. 4.) Screw the hydraulic hose support into the threaded pin in the drawbar frame. The support leg is attached to the drawbar in ST models. In T models, the support leg is mounted on the machine frame front beam. It is advisable to use an adequately powerful lifting hoist when attaching the ST model support leg to the machine.

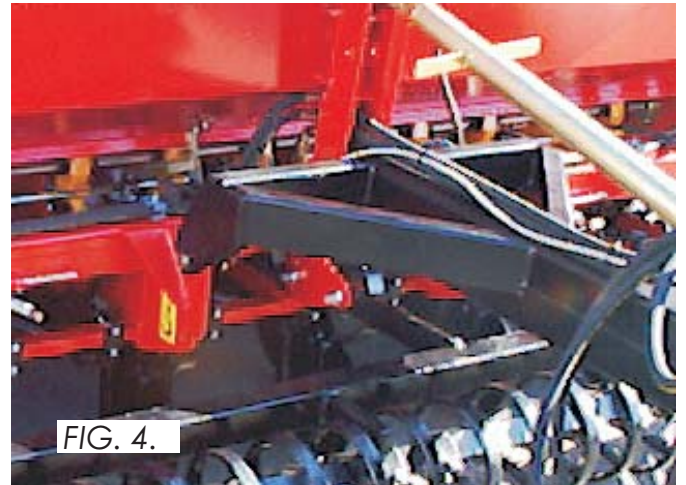

## MOUNTING THE FRONT FIELD DRAG

Attach the front field drag to mounting brackets at the front of the machine with screws. The drag can be adjusted in five different positions with alternative mounting holes (see illustrations below). Adjustment of the drag does not affect its ground clearance to any notable extent.

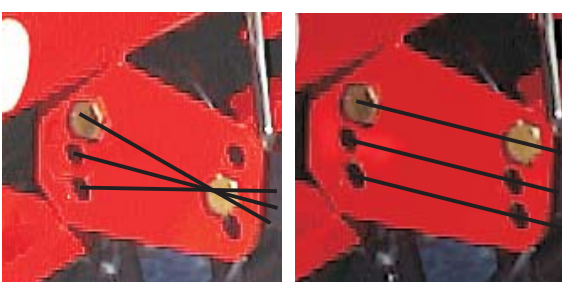

After you have mounted the front field drag, attach the hydraulic cylinders as shown in the illustration below. The hydraulic hoses are supplied as complete assemblies. The hoses must, however, be routed and attached as shown in the illustration.



### HYDRAULICS

The hydraulic hoses are supplied complete with ball valves, which are used to stop oil flow through the lines. When the valve handle is turned into the direction of the hose, the valve is open. When the handle is turned crosswise to the hose, the valve is closed.

### MOUNTING THE WIZARD MULTI-FUNCTION DRILL CONTROL ON-BOARD COMPUTER

The Wizard on-board computer is ready-assembled to the drill at the factory. Unless otherwise specified, the customer is responsible for the mounting of the monitor to the tractor. There are alternative places introduced in the following pictures, where the monitor can be fitted in the tractor cabin. Generally it is recommended, that the monitor is mounted to a place near by other controls. This way allows you to benefit from the tractor's own ergonomic solutions.

The monitor is assembled to the tractor by using its own 3-joint mount. With 2 screws supplied in the package, the mount is fixed into a place adequately sturdy to hold the monitor properly on its place.







In addition to the data transfer cable, which is connected to the monitor, there is a power supply cable which is connected to the tractor's electrical equipment plug. The equipment plug is compliant with ISO/TR 12369 standard, and it is very common in new tractors. The plug described in this standard is especially designed for demanding agricultural use.

In case there is no such plug in the tractor, it is recommended to obtain one to ensure troubleproof function of the equipment.

The most common reason for malfunction of electrical devices in agricultural machinery is a poor power supply plug.

## 9.6 DISPOSAL OF THE PACKAGING MATERIALS

The wooden and cardboard packaging materials can be discarded by burning them or by taking them to a refuse dump. The PVC packaging materials (bags and plastic strings) must be discarded in the manner according to national law either by recycling or by taking them to a refuse dump.

## 9.7 BALANCING WEIGHTS

To make use of the full potential that the Simulta can offer you in the form of ease of operation and saving time, it is imperative that it can be operated with full hopper loads. Always check before a sowing season that the tractor lift linkage is in good working order. Sometimes, particularly with smaller tractors, the tractor front end may prove too light, especially when operating with full hopper loads. In this case it is advisable to fit the tractor with front weights to ensure that approximately 20 % of the tractor weight is maintained on its front axle.

## 10 ACCESSORIES

### 10.1 SEED COULTERS

The seed coulters consist of two main component parts: The arm and the coulters tip.

The weighing of the coulters for proper penetration depends partly on the characteristics of its tip and also on the spring tension, which is centrally adjustable between 0-20 kilograms (0-44 lbs). Each coulters is also individually adjustable and is equipped with an adjustable low-position limit stop.

Different soils require a choice of different coulters to carry out the job. The single-disc wedged coulters is applicable for general use and the Suffolk-type coulters for hard soils.

#### SINGLE-DISC WEDGED COULTERS

The single-disc wedged coulters is an excellent choice for general use. It adapts itself both to soft and even hard soil conditions equally. Its characteristics come best into their own when used in fields where the soil composition varies greatly. The design of the coulters maintains a uniform drilling depth even in rapidly changing ground conditions. The rotating disc is extremely useful to prevent clogging, and thus, under very favorable conditions, it may even be used for direct sowing without prior tilling of the soil.

#### SUFFOLK COULTERS

The Suffolk coulters has been designed to operate in hard soil conditions. The angle of penetration of the coulters tip can be adjusted into three different positions. This will enable the coulters to perform well also on soft, even soils.

### 10.2 FERTILIZER COULTERS

#### NARROW-POINTED COULTERS

This is the most widely used general purpose fertilizers coulters. Its most common application is drilling in tilled soils. It will perform equally well in soft, organic soils and in hard, mineral-rich soils.

The coulters has an adjustable tip, the purpose of which is to protect the coulters against wear. The tips are available in three hardness categories: The standard tip, the hardened spring steel tip with a hard weld and the third type, which has an added wearing surface of special sintered steel. The coulters feed tube is equipped with a spur to prevent the clogging of the fertilizers tubes when lowered down on soft ground, for example, for the duration of time for filling up the hoppers.

#### DISC FERTILIZER COULTERS

The disc fertilizers coulters has a wider application range than the narrow-pointed coulters as it can be successfully operated in only lightly-tilled soil due to the rotation of its disc, which prevents clogging-up of straw or top-soil. The disc is manufactured of special high-quality steel to give it excellent wear resistance properties. Its hard spring suspension enables it to be used also for direct sowing.

### 10.3 ON-BOARD COMPUTER

The Simulta seed and fertilizers drill, both models T and ST, have a Wizard multi function drill control on-board computer as basic equipment.

In the S2500 and S3000 T-models the Wizard includes the following features :

- Forward speed measurement
- Area measurement, total area and trip
- Hopper level alarms on both hopper sections
- Fertilizers distribution shaft speed follow-up and alarm

The 3000 ST- and 4000 ST-models have in addition to the ones mentioned above, functions for seed distribution shaft speed follow-up and alarm and tramliner function to ease pesticides spraying.

The tramliner has four different methods to mark the tractor path for pesticides spraying :

- Symmetric
- Asymmetric to the right
- Asymmetric to the left
- 18-metre method



For the models 2500T and 3000T the tramliner is available as an optional equipment.

The drive computer can also be used to control the row markers, that are available for the drill as optional equipment.

Instructions for the use of the on-board computer are later on in this book.

## 10.4 FEED MECHANISM

The feed mechanism is a grooved push feeder type, which enables the feed rate to be adjusted by altering the effective length of the feeder grooved rollers.

The feed mechanism is chain driven from the machine's left hand side chain drive unit.

A stopper plate, located between the feed chamber and the hopper, enables the feed to be stopped at the chamber. By closing a part of the feeder mechanism with stopper plates, the machine can be used for sowing in narrow strips.

A curved bottom flap is located at the bottom of the feed chamber. The flaps will give in if a foreign object or a hard lump of fertilizer should enter the feed chamber.

You can adjust the position of the bottom flaps by a lever at the centre of the machine. The movement of the lever acts simultaneously on all flaps. For normal purposes the lever should remain in the second notch from the top (Position 1) but when sowing peas, you must open the bottom flaps by moving the lever into the third notch (Position 2). On the fertilizer side the normal operating position of the adjusting lever is in the second notch from the top (Position 1). If moved into the third notch position (Position 2), the feed rate will be increased by approximately 15%. Empty the machine by pushing the lever completely down and by turning the feed mechanism manually with the handle provided.

## 10.5 REAR HARROW

The purpose of the rear harrow attachment is to loosen and to level the top soil above the seed row level. Additionally, the harrowing unit spreads loose soil on top of the hard-packed wheel tracks to prevent the moisture from reaching the top of the soil and so minimizing the detrimental moisture evaporation. The rear harrow attachment is not designed to be used as a tilling implement and therefore its position must be adjusted so that it cannot interfere with the seed rows in the soil.

## 10.6 FRONT FIELD DRAG

The hydraulically operated front field drag of the ST models levels and smoothes out the topsoil and crushes it into ideally sized crumbs for drilling.

# 11 EXTRA EQUIPMENT

Each separate accessory item is supplied with its own printed assembling and attaching instructions. The instructions also cover a spare parts list for each accessory in case it is not included in the main parts catalogue supplied with this manual. It is advisable to attach any separate accessory parts list to the main parts catalogue for safe-keeping.

### PACKER ATTACHMENT

The packer attachment compression wheels pack the soil left between the tractor tyres to achieve a uniform degree of compression over the whole drilling width of the machine. It will also ease operations on a field as a part of the weight, which otherwise would be fully borne by the tractor, can be transferred to the packer wheels.

### SMALL SEED BOX

The small seed box is attached to the rear of the machine and the unit takes its drive from the chain drive unit by a roller chain. The unit can be used for sowing e.g. grass seed when the other sowing work permits. The small seed box can be calibrated in the same manner as for the main feed mechanism that is straight into calibration test troughs. The small seed box can also be equipped with a rationing unit for start-up additives and nutrients in order to drill in fertilizer in the same row as the seeds.

#### ROW MARKERS

Row markers are used when it is important to leave a clearly marked trail in the field for the adjacent run. The row marker gets its hydraulic pressure from the hydraulic line of the machine lifting. The Simulta drills from year 2002 have a factory-assembled bayonet for coupling of the row marker. The row marker operations are controlled from the tractor cabin by using the Wizard multi-function drill control. The row marking mode is chosen from the Wizard, there are four different ways how to drive. Marker arms will lower and rise, due to chosen program, simultaneously with the drill.

#### DISINFECTANT TREATING UNIT

The unit treats the seeds while in the process of being sown. This completely eliminates one stage in the seed handling process. The resulting treatment is very accurate and it leaves no treated seeds in the hoppers after stopping the drilling run. The unit can use all kinds of pulverized disinfectants.

#### REMOTE CONTROL UNIT

The Simulta drills can be equipped with a mechanical remote control for fertilizer feed enabling the operator to adjust the feed rate from the tractor cab during a sowing run. The remote feed control is very useful on fields with variations in the soil composition.

#### POWER HARROW DRAWBAR

The drill may be equipped with a special drawbar to enable the use of a power harrow with the drill. The drawbar couples the drill directly into the power harrow. Soil preparation and seed drilling can so be accomplished in a single working run.

The power harrow drawbar may be obtained either as a complete assembly or as a replacement extension boom. Both variants are supplied with an hydraulic extension hose, an extension cord for the areal meter, a shorter top link and an appropriate drawbar. The complete set includes in addition to the above mentioned items an 'A' frame, which is standard equipment for trailed Simulta drills. The power harrow drawbar is not recommended for use with the Simulta 4000 ST model due to its large size.

#### OTHER ACCESSORIES

A range of other accessories, not specified here, is available for Simulta drills to enable its operation in specific conditions.

Your Simulta Dealer will provide the information on the items in this range of accessories.

## 12 OPERATION AND CONTROL OF THE DRILL

### READ SAFETY INSTRUCTIONS BEFORE USING THE DRILL



#### 12.1 ADJUSTMENTS BEFORE A SOWING RUN

##### 12.1.1 WORKING POSITION

Before starting a sowing run adjust the top link so that the machine will maintain the normal working depth while the machine travels in a horizontal position.

The horizontal position is adjusted by turning the drawbar top link. This position is important as all the coulters have the same working depth (see Fig. 1).

The machine's horizontal position affects primarily the sowing depth of the fertilizer coulters.

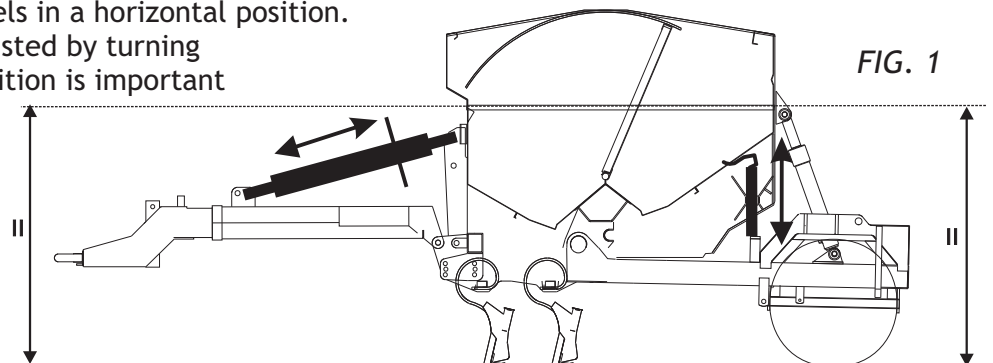

##### 12.1.2 FERTILIZER COULTER ADJUSTMENT

Fertilizer sowing depth is determined by the positioning of the ground support wheels. An adjustment screw is provided on both sides of the machine for raising or lowering of the support wheels. Individual adjustment of the support wheels becomes necessary when a wheel travels along a water furrow or alongside an open ditch. A scale is provided on the lower end of each side of the machine showing the related positions of the support wheels. The actual sowing depth must be ascertained from the field itself after a trial sowing run. The most advantageous fertilizer drilling depth is 2-4 cm (1"-1½") below the level of the seed row depth. The coulter design includes a spur, which helps to prevent the clogging of the fertilizer feed tubes even when the machine is lowered fully on soft soil (see Fig. 1).

##### 12.1.3 SEED COULTER ADJUSTMENT

The seed coulter sowing depth can be adjusted steplessly by increasing the spring pressure acting on the coulter arm. In 2500 series models an adjustment scale is provided on the right hand side of the machine for the seed coulters. In the 3000 and 4000 series models there are two adjusting scales located in the frame tube in front of the machine. The central adjustment in the 2500 models is carried out by turning an adjustment screw at the rear centre of the machine with the handle provided. The adjustment in models 3000 and 4000 is done by turning the adjusting screws on the front side of the machine. The sowing depth is increased by increasing the spring pressure (see Fig. 2).

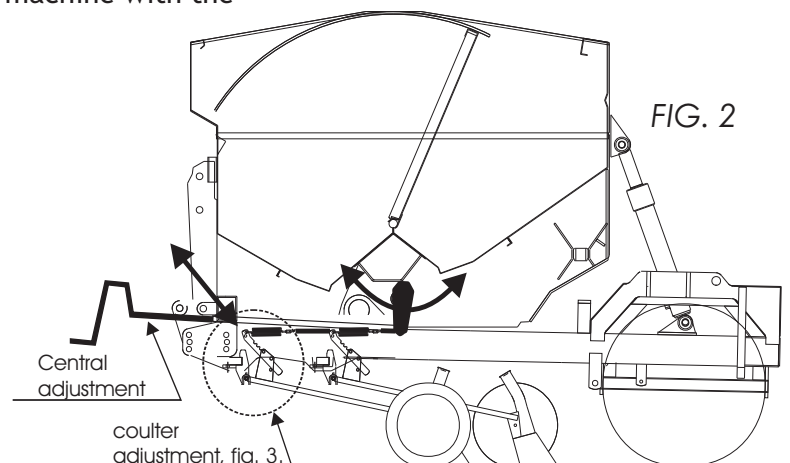



Individual coulter adjustment is carried out by altering the length of the notched spring anchor arm. Individual adjustment is required, for example, when a coulter follows the line of a tractor wheel, where the soil is compacted and the penetration of the coulter is decreased. The coulter travel lower limit can be adjusted by turning the adjusting nut on the low position limiter. The lower position limits are factory-set (see Fig. 3).

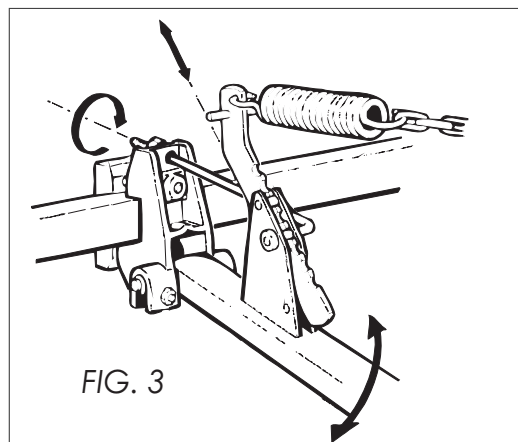

### 12.1.4 HUB COUPLING

The hub coupling is located on the left side of the machine on the roller wheels axle. The hub coupling is used to release the chain from between the roller wheels and the lower coupled wheel for the duration of transfer drive. We recommend doing this procedure, particularly if the transfer distance is several kilometers, so that unnecessary wear can be avoided. The spring-loaded coupling can be released by pressing and rotating it counter-clockwise 1/6 of a turn by hand or by calibration handle so that the lockpin cams can move outward. The re-connecting takes place in the same way, in which case the Lockpin cams remain in their notches and traction is connected. The coupling is used when the machine is in the upper position.

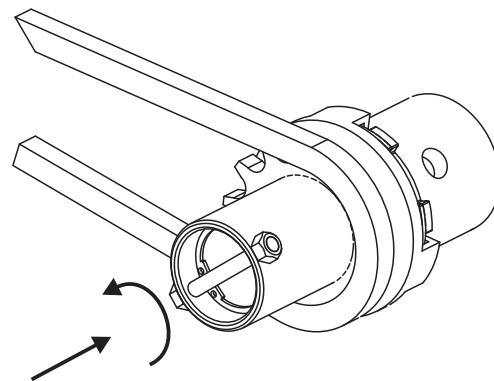

**NOTE! THE WIZARD WILL NOT SOUND AN ALARM ABOUT A RELEASED COUPLING!**

### 12.1.5 CHOOSING THE FEED RATES AND CALIBRATION TESTING

The feed rates are adjusted by turning the adjusting knobs located on the right hand side panel of the machine. The scales, which provide the values to choose from, are the main scale on the adjusting knob locking latch and the circular scale on the outer face of each adjusting knob. A circular groove cut into the knob outer circumference determines the position of the knob in relation to the main scale. The sowing chart gives guide values for adjusting the feed rates. The columns in the chart indicate the feed volume per hectare and the rows indicate the related settings of the two adjustment scales. The lower, larger digits are the values on the main scale and the upper, smaller digits are the values on the circular scales on each adjusting knob (see Fig. 4).



The Sowing Chart is provided both on the machine's top cover and in this manual. The grain variety is first chosen from the lines in the diagram. The intersection of the required sowing rate from the vertical scale and the variety line determines the relative positions of the main and adjusting knob scales directly below the intersection point.

For example, suppose that barley is sown at a required feed rate of 200 kg per hectare. The corresponding adjustment setting on the scales is then 4.7, i.e. 4 on the main and 7 on the knob scale. The adjusting knob is now turned so that the groove on the knob circumference is moved to position 4 on the main scale. The knob is then turned further until the position 7 on the knob scale is brought in line with the locking latch of the main scale.

Run a calibration test before you make the final decision on the required feed rate. The degree of cleanliness, the specific gravity value and even specific seed treatments affect the flow characteristics of the seeds within the feeding mechanism.

When compiling the Sowing Chart, a 5 % allowance has been made for wheel slip due to the sinking of the tyres. The slippage value may in practice vary between 5-10% depending on the prevailing soil

conditions. The calibration test must never be carried out on the basis of the reading given by the areal meter alone. The calibration test can be run separately for the seeds and for the fertilizer if so required. In this case, the drive chain sprocket securing cotter pin must be moved to the outer, alternate hole. When running the calibration test for small seeds, the chain drive arrangement must be adjusted into the small seed sowing position before the test.

When you test the fertilizer side calibration, use the calibration troughs in the same manner as when testing the seeds. Choose the required feed rate from the Sowing Chart and the corresponding scale readings noted. Set the feed rate adjusting knob to the reading values thus obtained. The test is carried out in the following manner: Using the handle provided with the machine turn the feed shaft end at a rate of 1 turn in 2 seconds for the accumulated values given in the tables below:

Fertilizer side test (turning the fert. feed shaft by handle as in Fig. 5)

	turns./are	$a = 100 \text{ m}^2 = 0,0247 \text{ acres}$ $ha = 10000 \text{ m}^2 = 2,471 \text{ acres}$
S-2500 T	30.4	
S-3000 T/ST	25.4	
S-4000 T/ST	18.9	

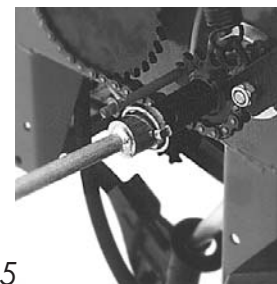

FIG. 5

- Seed side test (turning agitator shaft end by handle as in Fig. 6)

	turns./are
S-2500 T	5.3
S-3000 T/ST	4.4
S-4000 T/ST	3.3 (Fig. 6)

The amount of seed and fertilizer collected in the test troughs is weighed and the resulting weights multiplied by one hundred. The resulting figure represents the amount of material the machine will sow to one hectare with that particular adjustment. The figure thus obtained is compared with the feed rate in the Sowing Chart and a possible corrective action is then taken by turning the adjusting knob. Always adjust from smaller value settings upwards to higher values. This method will counteract any possible backlash in the adjusting knob threads. An alternative method to the calibration test on the seed side is to make a trial run with the calibration troughs in place. A trial run will eliminate also any slippage occurring due to soil conditions or tyre pressures. The resulting figure is the exact feed rate value corresponding with the prevailing conditions.

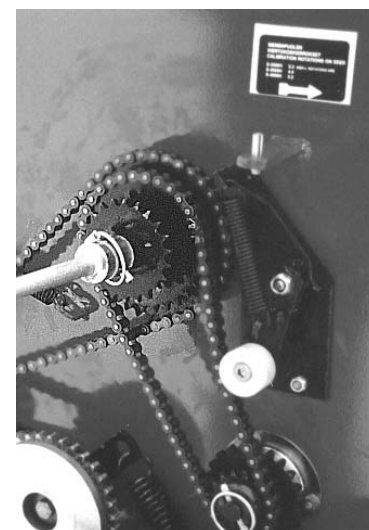

FIG. 6

Example:

210 kg oats and 500 kg of fertilizer to be sown on 1 hectare

SEED:

1. Fill up the seed hopper with at least 100 kg (220 lbs) of seed.
2. Lift up the machine.
3. Remove the drive chain cover.
4. Remove the sprocket retaining cotter pin and insert it in the outer cotter pin hole of the same shaft.
5. Check the Sowing Chart to ascertain the adjustment scale readings for a feed rate of 210 kg/ha for oats. The main scale reading will be 6 and the knob scale reading 3.
6. Adjust the feed rate by turning the adjusting knob on the left hand side of the machine. Bring the circumferential groove to setting 6 on the main scale and after this, turn the knob further for 3 more notches to obtain the reading 3 on the knob scale. Always adjust from zero value upwards.
7. Remove the retaining pins from the calibration test trough support arms to let the troughs fall down below the feed chambers into the test position. Check that no seeds can bypass the test troughs.
8. Attach the calibration test handle into the end of the seed agitator shaft and turn the handle for a

few turns. Check that the seeds pass through all of the feed chambers. Empty the troughs by tipping the collected seeds back into the hopper. Replace the troughs in their test position.

9. Rotate the handle at a speed of 2 turns/sec., the speed rate required for the test (check tables for no. of turns required for each machine model).
10. Weigh the seeds collected in the troughs after the completion of turns.
11. If there is a marked difference between the value given in the Sowing Chart and the value obtained from the test, re-adjust the settings and re-run the test.

**PLEASE NOTE THAT THE VALUES GIVEN IN THE SOWING CHART ARE FOR GUIDANCE ONLY, DUE TO VARIATIONS IN THE COMPOSITION OF THE SOWED MATERIALS, THEIR TREATMENTS ETC.**

### FERTILIZER:

1. Fill up the fertilizer hopper with at least 100 kg (220 lbs) of fertilizer.
2. Lift up the machine.
3. Remove the drive chain cover.
4. Remove the sprocket retaining cotter pin and insert it in the outer cotter pin hole of the same shaft.
5. Check the Sowing Chart to ascertain the adjustment scale readings for a feed rate of 500 kg/ha for fertilizer. The main scale reading will be 5 and the knob scale reading 6.
6. Adjust the feed rate by turning the adjusting knob on the L.H. side of the machine. Bring the circumferential groove to setting 5 on the main scale and after this, turn the knob further for 6 more notches to obtain the reading 6 on the knob scale. Always adjust from zero value upwards.
7. Move the test troughs over to the fertilizer feed side, release the funnel shaft retaining rubber straps and move the shaft to the rear to make room for the insertion of the test troughs below the feed chambers. Check that no fertilizer can bypass the troughs.
8. Attach the test handle to the end of the fertilizer hopper feed shaft and rotate the handle for a few turns to check that fertilizer passes through all feed chambers. Tip the collected fertilizer from the troughs back into the hopper and refit the troughs back in place.
9. Rotate the handle at a speed of 2 turns/sec., the speed rate required for the test (check tables for number of turns required for each model).
10. Weigh the fertilizer collected in the troughs after the completion of turns.
11. If there should be a marked difference between the value given in the Sowing Chart and the value obtained from the test, re-adjust the settings and re-run the test.

**PLEASE NOTE THAT THE VALUES GIVEN IN THE SOWING CHART ARE FOR GUIDANCE ONLY, DUE TO VARIATIONS IN THE COMPOSITION OF THE SOWED MATERIALS, THEIR HUMIDITY LEVELS ETC.**

## SMALL SEED SOWING AND DRIVE CHAIN REVERSAL

The Simulta drills are also suitable for sowing small seeds, when the feed shaft speed is reduced. This is accomplished by reversal of the chain drive sprocket arrangement.

The drive sprockets are in their normal positions when the smaller sprocket is attached to the feed shaft (see Fig. 7a). The drive is reversed by first removing the retaining pins from each shaft and, in case of T and ST models, the outer sprocket from the intermediate shaft, which drives the optional small seed box. It is advisable to remove the two sprockets and the drive chain as a complete assembly keeping the chain taut so that the sprocket teeth do not change their positions in relation to the drive chain. This also helps to line up the retaining pin holes automatically (see Fig. 7b).

The calibration test for T and ST model drills is made by turning the end of the intermediate shaft and thus the reversal of the chain drive sprockets has no effect on the number of turns required for the test.





**TRIAL RUN FOR CALIBRATION**

A trial run is a way to obtain a more accurate result than the manual calibration test can produce. The run will also take into account the actual wheel slip and any changes in the feed rates due to the machine vibrations occurring during running.

Carry out the trial run as follows:

1. Open up the fertilizer feed flow.
2. Adjust the machine as per instructions for the calibration test.
3. Measure the machine's traveling distance required for completing the sowing of an area of 100 sq.m (1 are) - i.e. the travel distance for the particular drill model.

Travel distances for different working widths per 1 are:

S-2500 T	40 m
S-3000 T/ST	33.3 m
S-4000 T/ST	25 m

(the travel distances will stay the same irrespective of the position of the feed chain drive sprockets)

4. Check first that the seeds are passing out unobstructed through each feed chamber by driving outside the test for about 10 meters (33 ft) with the drill in its proper working position.
5. Empty the trough back into the hopper.
6. Lower the machine into working position and carry out the test run over the measured distance.
7. Measure the amount fed into the trough multiplying the resulting value by 100 to obtain the weight of seeds required in kilograms per hectare.
8. Should any checking be required for, refer to the Chapter Calibration Test.
9. Do not forget to re-open the fertilizer feed mechanism and remove the test trough after the field test.

**HOPPER CAPACITIES**

		2500T/m <sup>2</sup>	3000T /m <sup>2</sup>	3000ST/m <sup>2</sup>	4000ST/m <sup>2</sup>
A	Fertilizer	-	-	0	0
	Seed	-	-	3,4	4,5
B	Fertilizer	0,9	1,1	1,6	2,2
	Seed	1,4	1,5	2,6	3,4
C	Fertilizer	1,0	1,3	1,8	2,5
	Seed	1,3	1,4	2,4	3,1
D	Fertilizer	1,2	1,4	2,3	3,0
	Seed	1,1	1,3	1,9	2,6
E	Fertilizer	1,3	1,5	2,4	3,2
	Seed	1,0	1,2	1,8	2,4
F	Fertilizer	1,4	1,7	2,6	2,1
	Seed	0,9	1,0	1,6	3,5

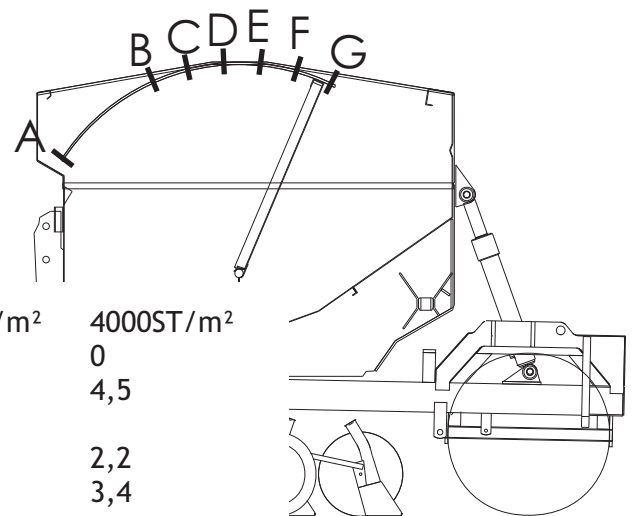

## 12.1.6 SOWING CHART

lbs/  
acre

kg/  
ha

### SOWING CHART

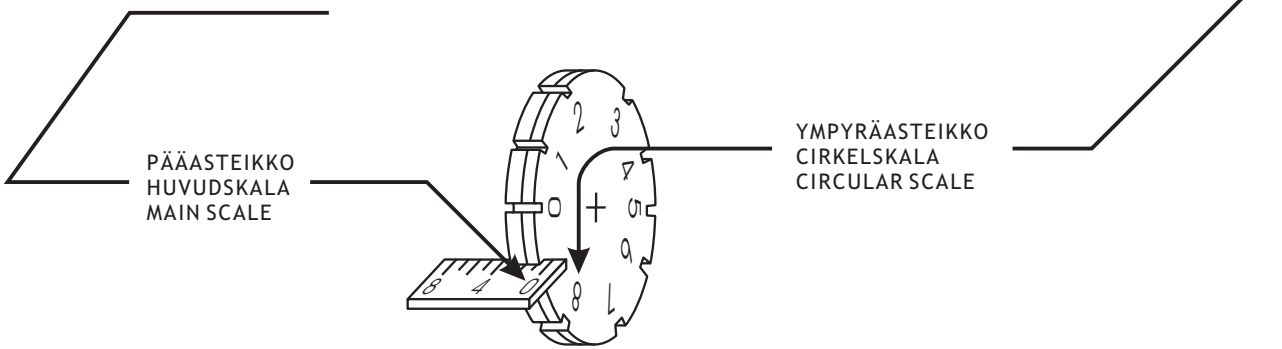
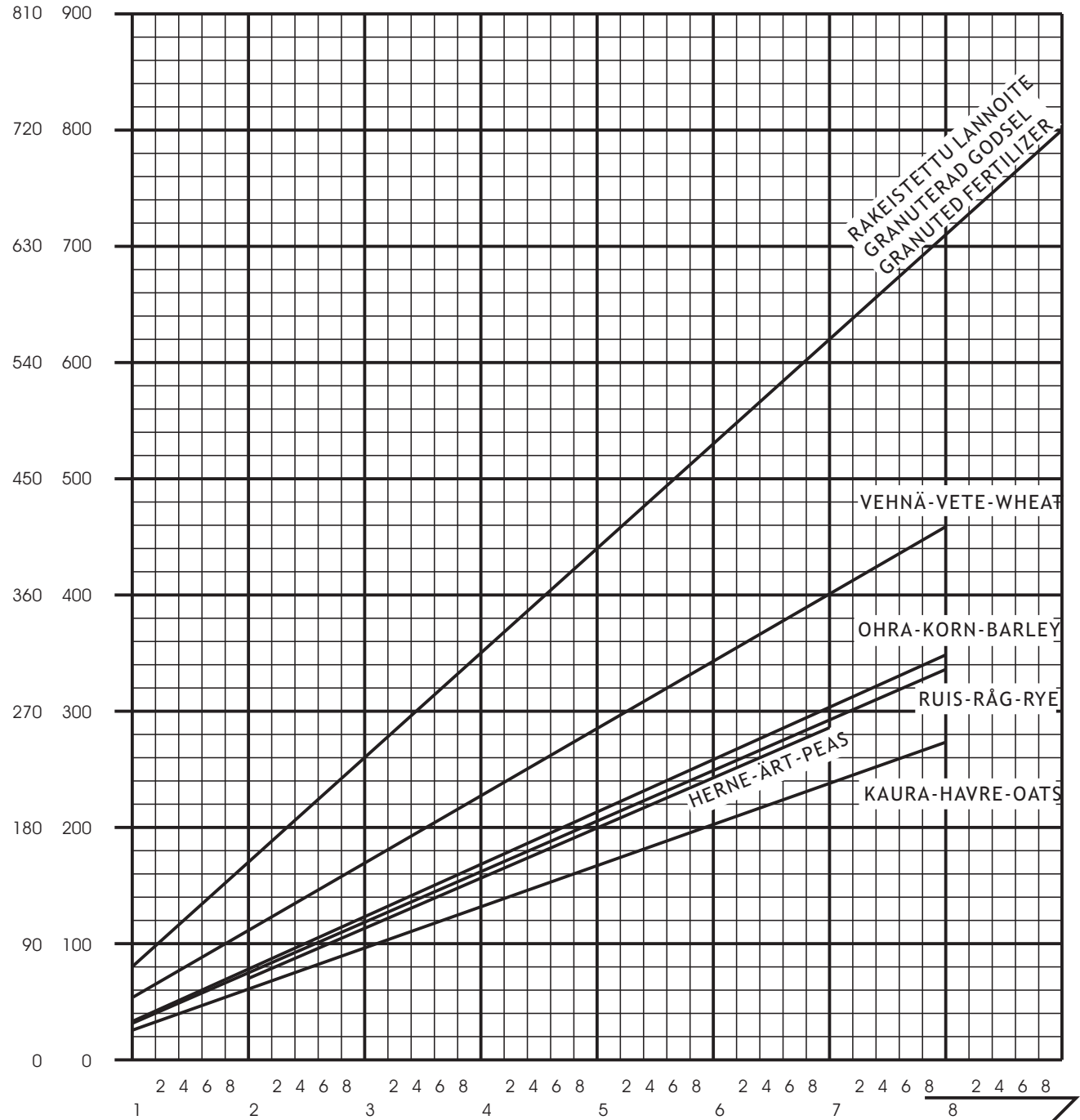

THE VALUES SHOWN IN THE SOWING CHART ARE FOR GUIDANCE ONLY DUE TO THE VARIATIONS IN THE SEED AND FERTILIZER QUALITIES. THE SOWING RATES CAN BE ASCERTAINED BY CARRYING OUT A CALIBRATION TEST.

WHEN COMPILING THE SOWING CHART, A 5% ALLOWANCE HAS BEEN MADE FOR WHEEL SLIP. THE SLIPPAGE MAY IN PRACTICE VARY BETWEEN 5-10% DEPENDING ON THE PREVAILING SOIL CONDITIONS.

### 12.1.7 ADJUSTMENTS FOR CALIBRATION TEST

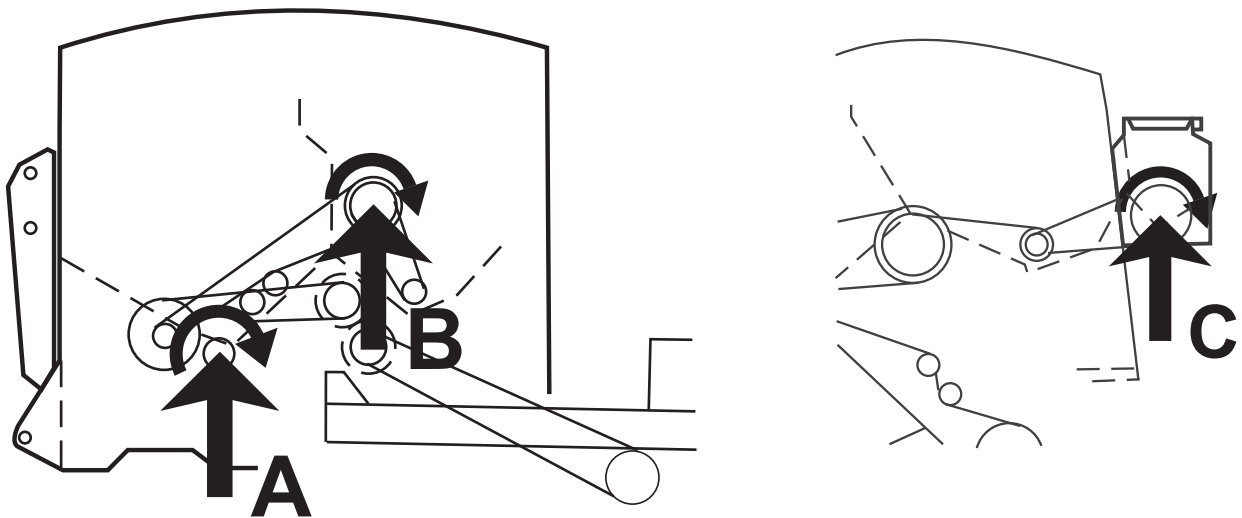

- A = On the fertilizer side by turning the feed shaft.
- B = On the seed side by turning the intermediate shaft.
- C = On the small seed box drive.

### NORMAL SOWING

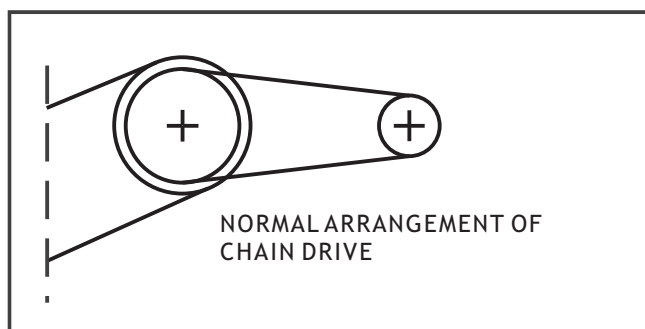

POSITION OF THE BOTTOM FLAP	
Fertilizer	1 - ( 2 )
Grain seed	1
Peas	2

### Calibration test turns

<b>A</b>	Turns/100m <sup>2</sup>
S-2500 T	30,4
S-3000 T/ST	25,4
S-4000 T/ST	18,9

<b>B</b>	Turns/100m <sup>2</sup>
S-2500 T	5,3
S-3000 T/ST	4,4
S-4000 T/ST	3,3

a=100m<sup>2</sup> =0,0247 acres  
 ha=10000m<sup>2</sup>=2,471 acres



## SMALL SEED SOWING FROM THE MAIN HOPPER

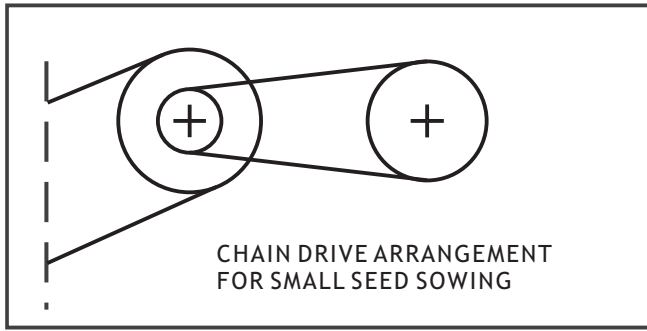

Bottom flap position **0**

Calibration test turns

<b>A</b>	Turns/100m <sup>2</sup>	<b>B</b>	Turns/100m <sup>2</sup>
S-2500 T	30,4	S-2500 T	5,3
S-3000 T/ST	25,4	S-3000 T/ST	4,4
S-4000 T/ST	18,9	S-4000 T/ST	3,3

a=100m<sup>2</sup>=0,0247 acres  
ha=10000m<sup>2</sup>=2,471 acres

lbs/ acre kg/ ha **SMALL SEED SOWING CHART from the hopper**

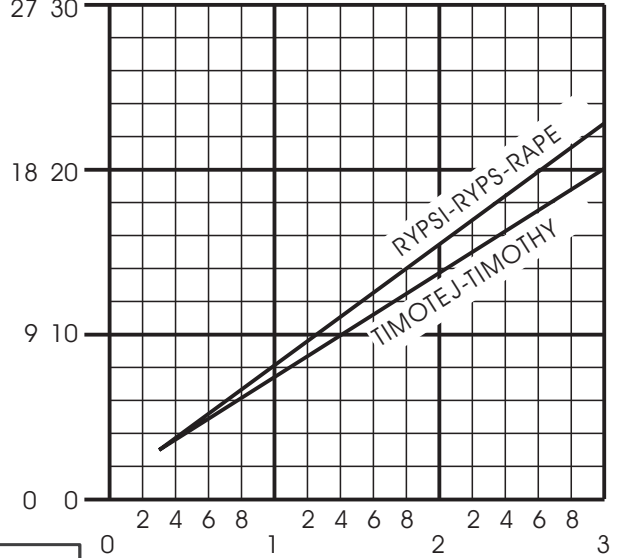

## SMALL SEED SOWING FROM THE SMALL SEED BOX (optional equipment)

Bottom flap position **0**.  
Chain sprocket **Z37**

Calibration test turns

<b>B</b>	Turns/100m <sup>2</sup>
S-2500 T	5,3
S-3000 T/ST	4,4
S-4000 T/ST	3,3

<b>C</b>	Turns/100m <sup>2</sup>
S-2500	3,1
S-3000	2,6
S-4000	2,0

kg/ha **SOWING CHART for small seed box**

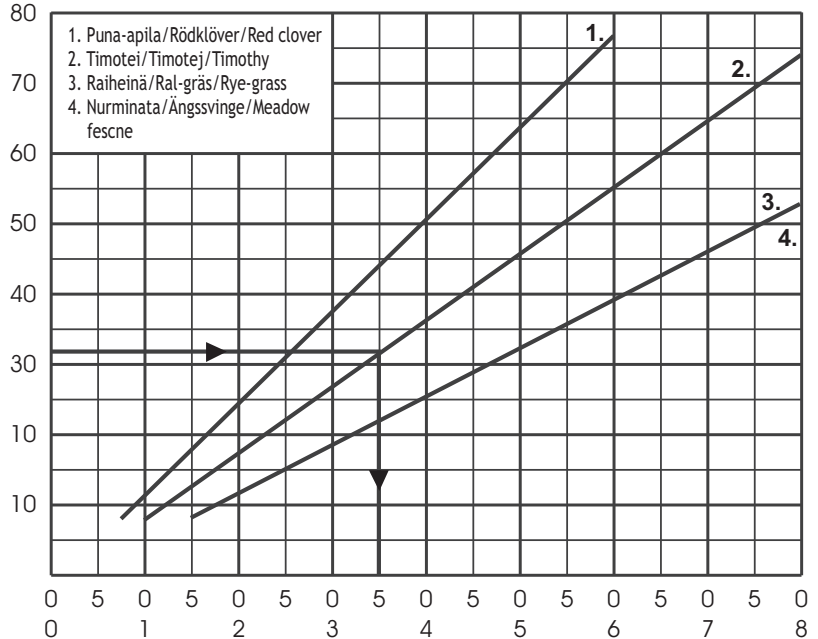

The values given in the chart are for guidance only, due to variations in the quality of seeds. Run calibration test to ascertain values. For example, required sowing rate 32 kg/ha timothy, use adjustment settings 3.5.

## 12.2 USER GUIDE FOR THE ON-BOARD COMPUTER JUNKKARI WIZARD



WIZARD MULTI-FUNCTION DRILL CONTROL  
FOR JUNKKARI SIMULTA SEED AND FERTILIZER DRILL



Junkkari Oy  
62375 YLIHÄRMÄ FINLAND  
TEL. +358-(0)6-4835111  
Fax: +358-(0)6-4835295  
e-mail: junkkari@msk.fi  
Internet: www.junkkari.fi

ENGLISH



Electro - Magnetic Compatibility (EMC)

# 1 CONTENTS

	PAGE
2. DEFAULT SETTINGS.....	33
3. SUMMARY OF FUNCTIONS.....	34
4. FORWARD SPEED/SENSOR CALIBRATION.....	35
5. AREA/WIDTH.....	37
6. TRAMLINING.....	39
6.1 SYMMETRICAL TRAMLINING.....	40
6.2 ASYMMETRICAL LEFT SIDE TRAMLINING.....	41
6.3 ASYMMETRICAL RIGHT SIDE TRAMLINING.....	42
6.4 18 METRE TRAMLINING.....	43
7. FERTILIZER DISTRIBUTION SHAFT SPEED/ALARM.....	46
8. SEED DISTRIBUTION SHAFT SPEED/ALARM.....	47
9. MACHINERY GUARD.....	48
10. HOPPER LEVEL ALARM.....	49
11. ROW MARKING.....	50

The Junkkari multi-function drill control has an illuminated 4-digit display with functions for :

- Forward speed km/h
- Area worked (total area and trip)
- Bout count and tramline bouts
- Fertilizer distribution shaft and seed distribution shaft control
- Hopper level alarm
- Machinery guard

The on-board computer has two memory registers to record a trip and the total area worked. Data is automatically stored in memory when the instrument is turned off.

In normal operating mode the instrument display defaults to the tramlining channel unless either the area channel is selected or an alarm condition exists.

The instrument must be initially calibrated to suit the implement being controlled. The program mode allows default settings to be altered as required.

The drive computer can also be used to control the hydraulic row marker functions.

## 2 DEFAULT SETTINGS

The Wizard has three kinds of default settings :

The Wizard default settings (first default setting)

- In case the monitor has to be reset, these are the settings it will return to.

Settings, that are programmed at Junkkari : (second default setting)

- Programmed at the factory
- Especially altered settings for Simulta

User preference settings : (third default setting)

The settings, that the operator is able to program :

To start programming, select function to alter and press **+1** button for three (3) seconds, set value with  button.

Function	Programmable value	default setting (Wizard)	default setting	default setting (User)
1. Km/h	Wheel circumference*	2.000 m	about 1.32	-----
2. Ha	Working width	2.000 m	machine width	-----
3. Tramline	Tramline marking	Sy.04	Sy/Al/Ar/18m/OFF	-----
4. Fert. shaft speed	Low speed alarm	0.000rpm	0.01 with switch 0.00 w/o switch	-----
5. Seed shaft speed	Low speed alarm	0.000rpm	0.01 with switch 0.00 w/o switch	-----
6. Hopper level	Hopper level alarm on/off	1	1=ON	-----

\* press **+1** and  to start automatic speed calibration. Press  after 100m drive.

The Wizard default settings :

Press and hold **+1** to switch on power. Select function with **+1** button. Set value with  button.

Function	Programmable value	default setting (Wizard)	default setting	default setting (User)
1. Km/h	No function	-	-	-----
2. Ha	Total area (unprogrammable)	-	-	-----
3. Tramline	No function	1	1=ON/0=OFF	-----
4. Fert. shaft speed	Speed pulse / round	8.000	12 with switch 0 w/o switch	-----
5. Seed shaft speed	Speed pulse / round	8.000	12 with switch 0 w/o switch	-----
6. Machinery guard	Allowed deviation %	25 %	25	-----



### 3 OPERATING SUMMARY

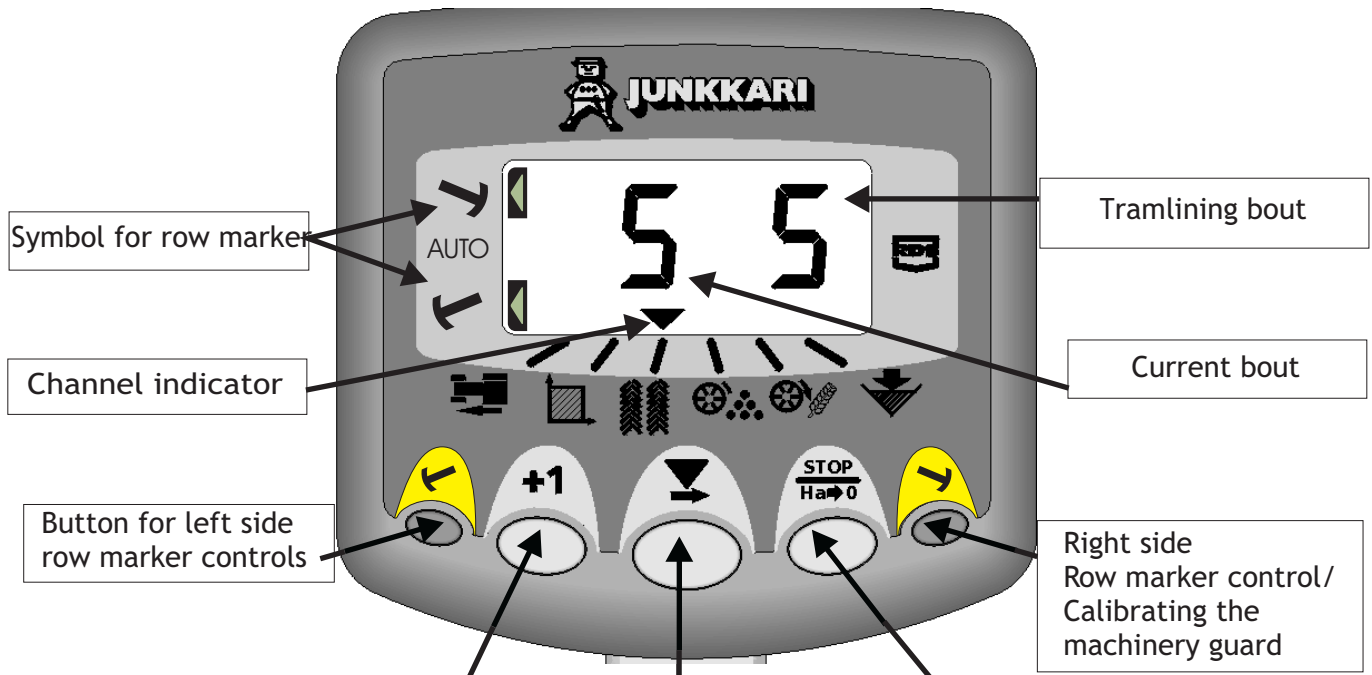

**EITHER :**

1. Select the  channel then PRESS **+1** to switch between Area Total 1 and 2.

OR

2. Select the  channel and PRESS **+1** to manually advance the Bout Number.

OR

3. HOLD **+1** continuously to select the programming mode. (Normal Mode is resumed when the button is released).

Press to select the display function

PRESS **STOP Ha→0** to override automatic advance of bout number if drill is lifted (press again to resume)

OR

HOLD **STOP Ha→0** to reset currently displayed Area Total

CH	Function	Units
1	Forward speed	km/h
2	Area Total 1 or 2	ha
3	Tramline / Current bout	-
4	Fertilizer shaft speed	rpm
5	Seed shaft speed	rpm
	Machinery guard	
6	Hopper level alarm	"alar"

# 4 FORWARD SPEED/SENSOR CALIBRATION

## 1 SELECT FORWARD SPEED

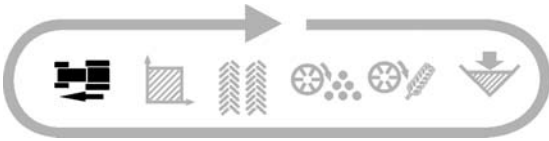

If the forward speed goes less than 2 km/h, the instrument bleeps twice and the display alternates between the selected channel and the forward speed channel.



## 2. SPEED SENSOR MANUAL CALIBRATION

The speed sensor has been mounted to the end of the fertilizer distribution shaft in the Junkkari Simulta drill. The theoretical calibration figure equals the rolling circumference (diameter x 3,142) of the land wheel in metres. The average default value is **1.32**.

Automatic calibration is however more accurate in field conditions.

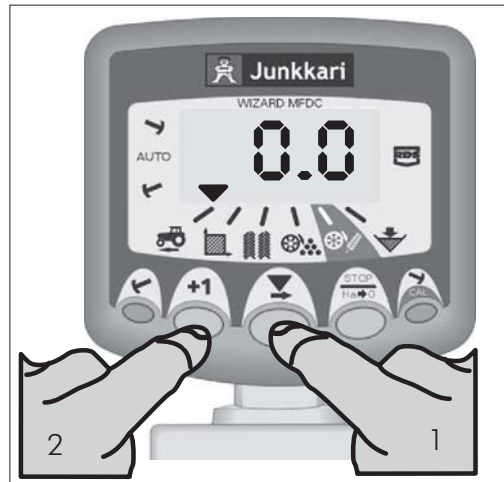

Select the  channel and release.

HOLD **+1** CONTINUOUSLY and...

PRESS  to select the digit or decimal point.

 2.000,  2.000,  2.000,  2.000, etc

HOLD  to change the digit or move the decimal point.

 2.100,  2.200,  2.300,  2.400, etc

RELEASE  to select the next digit and repeat the procedure as necessary.

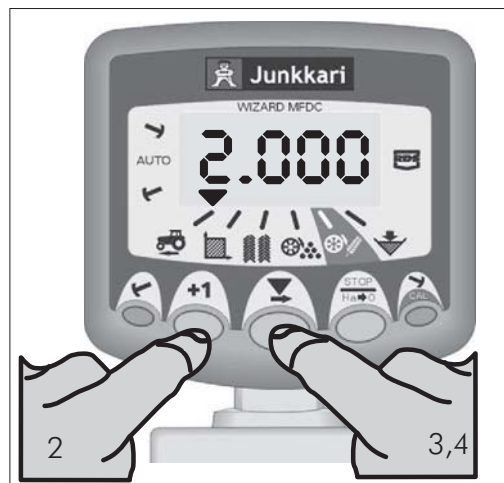

RELEASE **+1** to end programming. The set values are saved to the device memory.

### 3. AUTOMATIC SPEED CALIBRATION

Auto-calibrate in field conditions for maximum accuracy.

Set the markers 100 m apart and position the vehicle opposite the first marker.

Select the  channel.

HOLD **+1** CONTINUOUSLY.

The instrument enters programming mode after three (3) seconds.

PRESS .

Auto calibration will then begin.

Drive up to the second marker.

The instrument displays the total number of sensor pulses received over the distance.

PRESS .

Speed calibration is now complete.

The calibration factor is automatically calculated and stored in the memory.

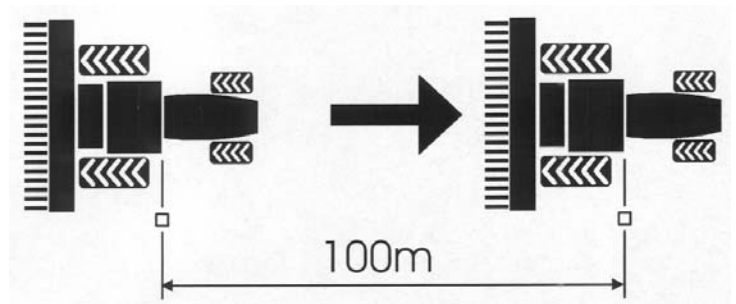
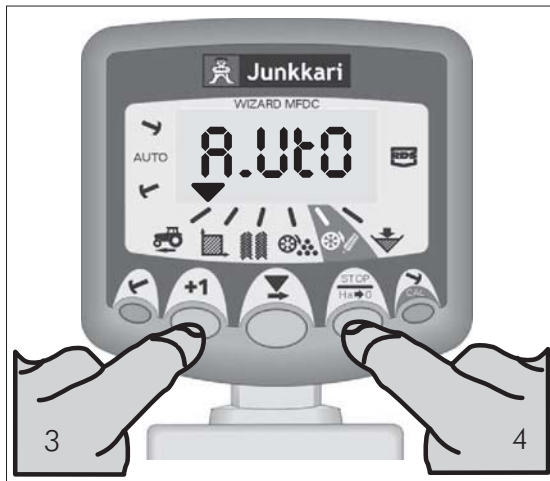

# 5 AREA/WORKING WIDTH

## 1. SELECT AREA CHANNEL

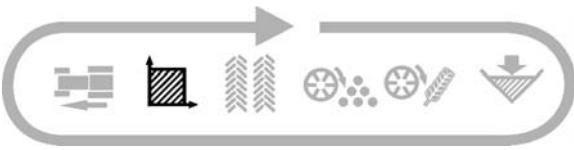

There are two area registers, each independently resettable.



## 2. SELECT AREA REGISTER

PRESS **+1** to cycle between the two area registers, TOT1 and TOT2.  
 The display shows the area accumulated since the last area reset.  
 These two area registers can be accumulated separately, one can be used for total worked area and the other can be used, for example, to accumulate area worked at one field.

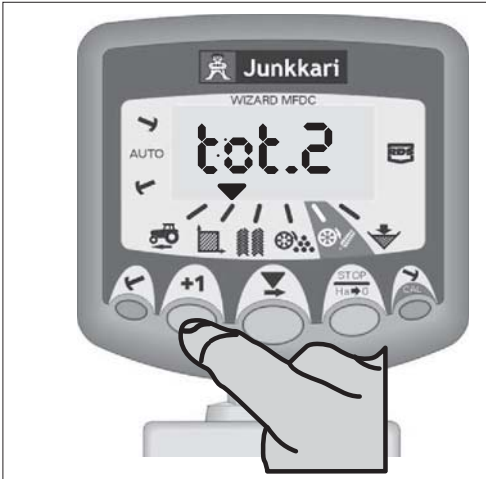

## 3. RESET AREA REGISTER

Select the TOT1 or TOT2 and release.  
 HOLD **STOP** for 5 seconds.  
Ha 0



The total then resets to zero.

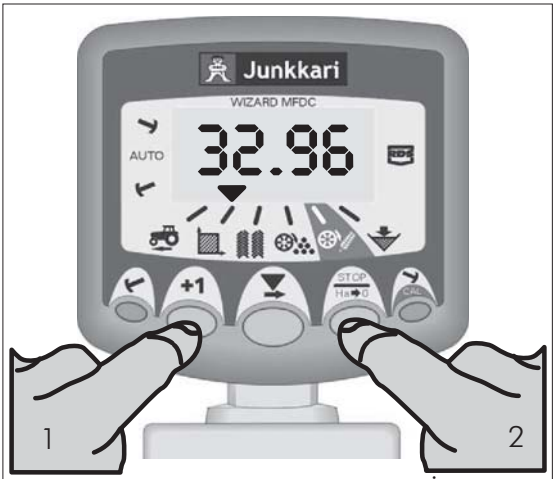



#### 4. PROGRAMMING THE WORKING WIDTH

The working width of the machine in metres.

Select the  channel.

**HOLD +1 CONTINUOUSLY**

The instrument enters the programming mode after 3 seconds.

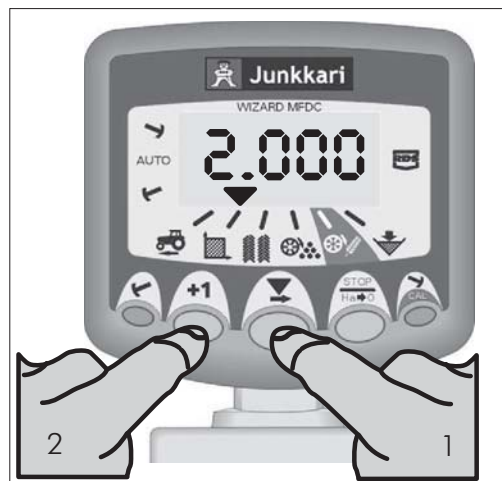

**PRESS ▼** to select the digit or decimal point.

 2.000,  2.000,  2.000,  2.000, etc

**HOLD ▼** to change the digit or move the decimal point.

 2.100,  2.200,  2.300,  2.400, etc

**RELEASE ▼** to select the next digit.

**RELEASE +1** to end programming. The set values are saved to the device memory.

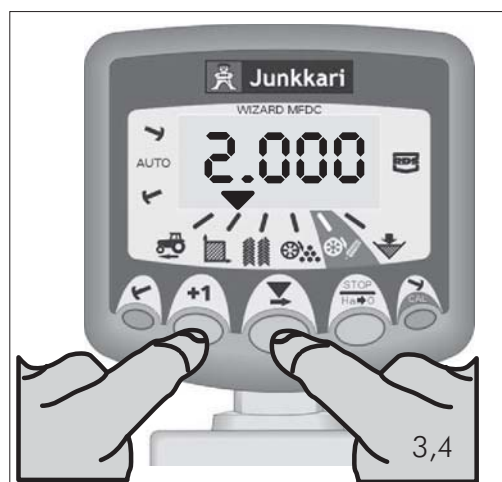

## 6 TRAMLINING

There are four systems of tramlining: symmetrical, asymmetrical left, asymmetrical right and 18 metre method. The tramline bout is programmable from 0 (no tramlining) to 15 in symmetrical, asymmetrical left and asymmetrical right sequences.

The display defaults to the  channel after 10 seconds (unless the AREA TOTAL was selected).

Selection of the asymmetrical tramlining is denoted by a decimal point on the display between the current bout number on the left and the tramline bout on the right.

Left or right asymmetrical tramlining is selected in the programming mode.

### 1. MANUALLY ADVANCE BOUT NUMBER

PRESS **+1** to advance the current bout number by one.

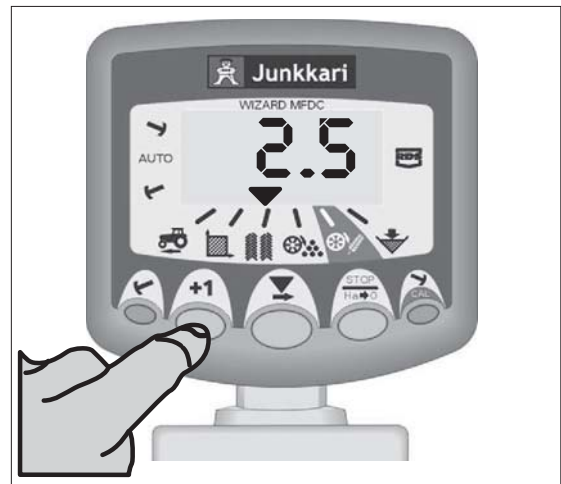

### 2. HOLD BOUT NUMBER when the machine is lifted

PRESS **STOP**  
**Ha→0** to hold the current bout when the drill is lifted.

This way the program will not register the lift of the machine as a change of bout. The row marking function stops as well.

The display flashes “stop”.

PRESS **STOP**  
**Ha→0** again to resume the normal bout sequence.

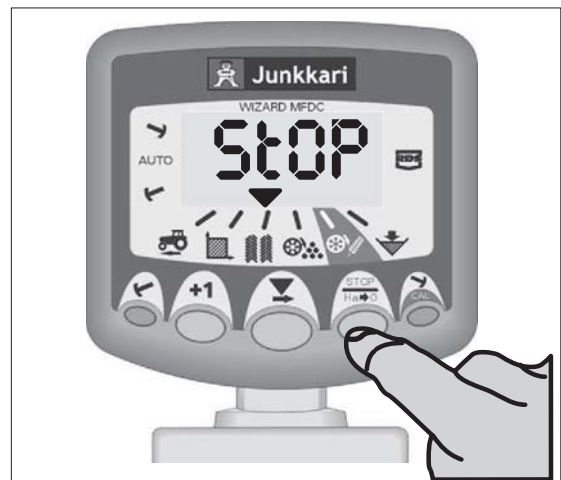

## 6.1 SYMMETRICAL TRAMLINING

2+2 seed spouts are closed during the tramline bout only. Refer to section 5 to programme the instrument for symmetrical tramlining. The instrument will beep once at the beginning of the tramline bout, and the display will continue flashing for the duration of the bout.

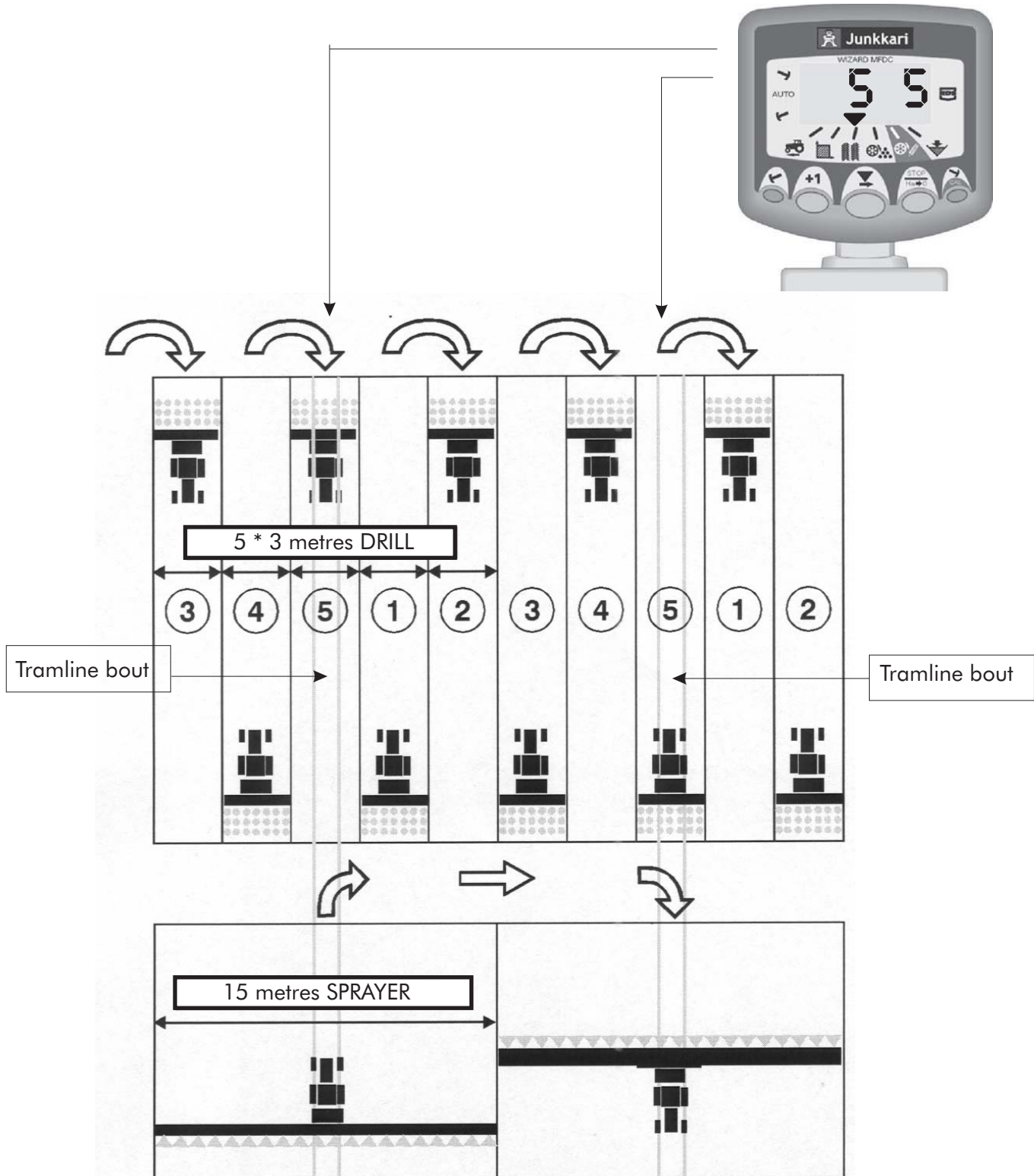

## 6.2 ASYMMETRICAL LEFT TRAMPLING

2 seed spouts are closed on the left hand side of the drill on bouts 1 and 6. Refer to the section 5 to programme the instrument for asymmetrical left trampling.

The instrument will beep once at the beginning of each tramline bout, and the display will continue flashing for the duration of the bout.

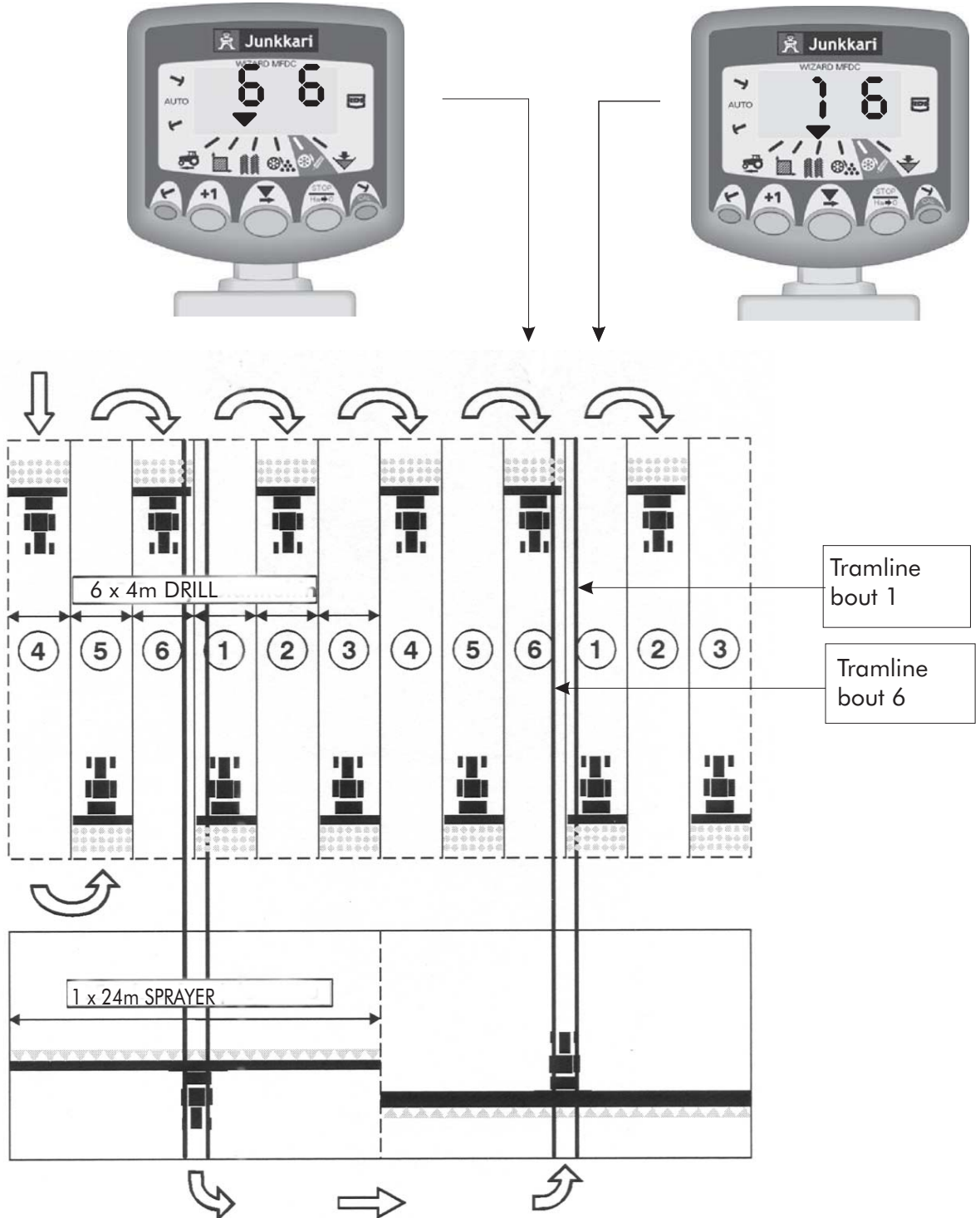



### 6.3 ASYMMETRICAL RIGHT TRAMLINING

2 seed spouts are closed on the right hand side of the drill on bouts 1 and 6. Refer to the section 5 to programme the instrument for asymmetrical left tramlining.

The instrument will beep once at the beginning of each tramline bout, and the display will continue flashing for the duration of the bout.

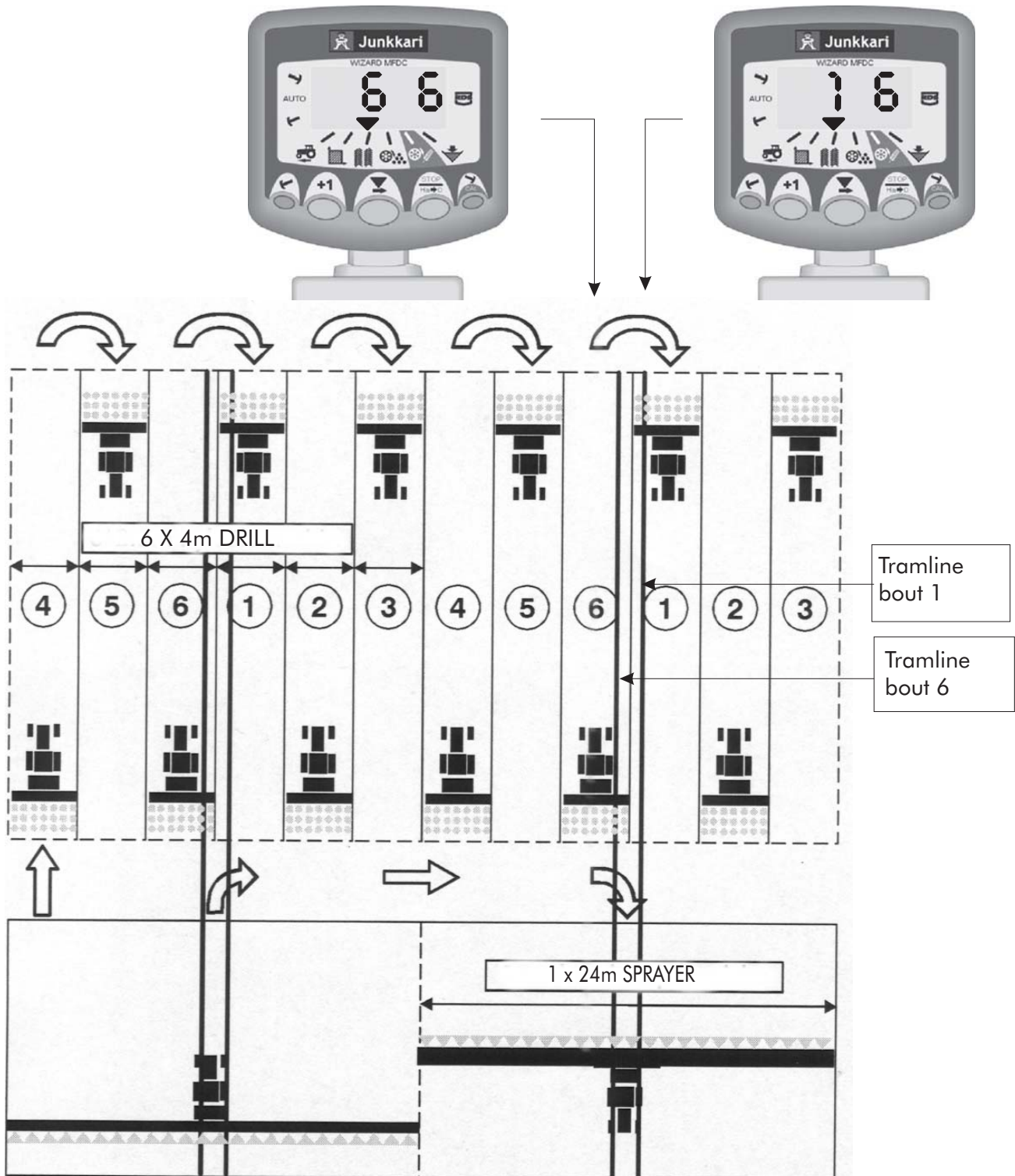

## 6.4 18 METRE TRAMLINING

This method is used in cases where the width of the drill is 4 metres and the width of the sprayer is 18 metres. In this case, the width of the sprayer is not evenly divisible by the width of the drill. As a result the tramlining combination switches must be mounted asymmetrically on the sides of centre of the drill. In this case, the drill requires two pairs of tramlining combination switches, one pair per side of the machine, and the center of the spraying tractor path will be in quarter of the drill working width (see illustration below).

Starting on bout 1 requires turning LEFT at the end of the first bout.

NOTE : To turn right at the end of the first bout, cycle the instrument display through to bout 10 before beginning.

The instrument will beep once at the beginning of each tramline bout, and the display will continue flashing for the duration of the bout.

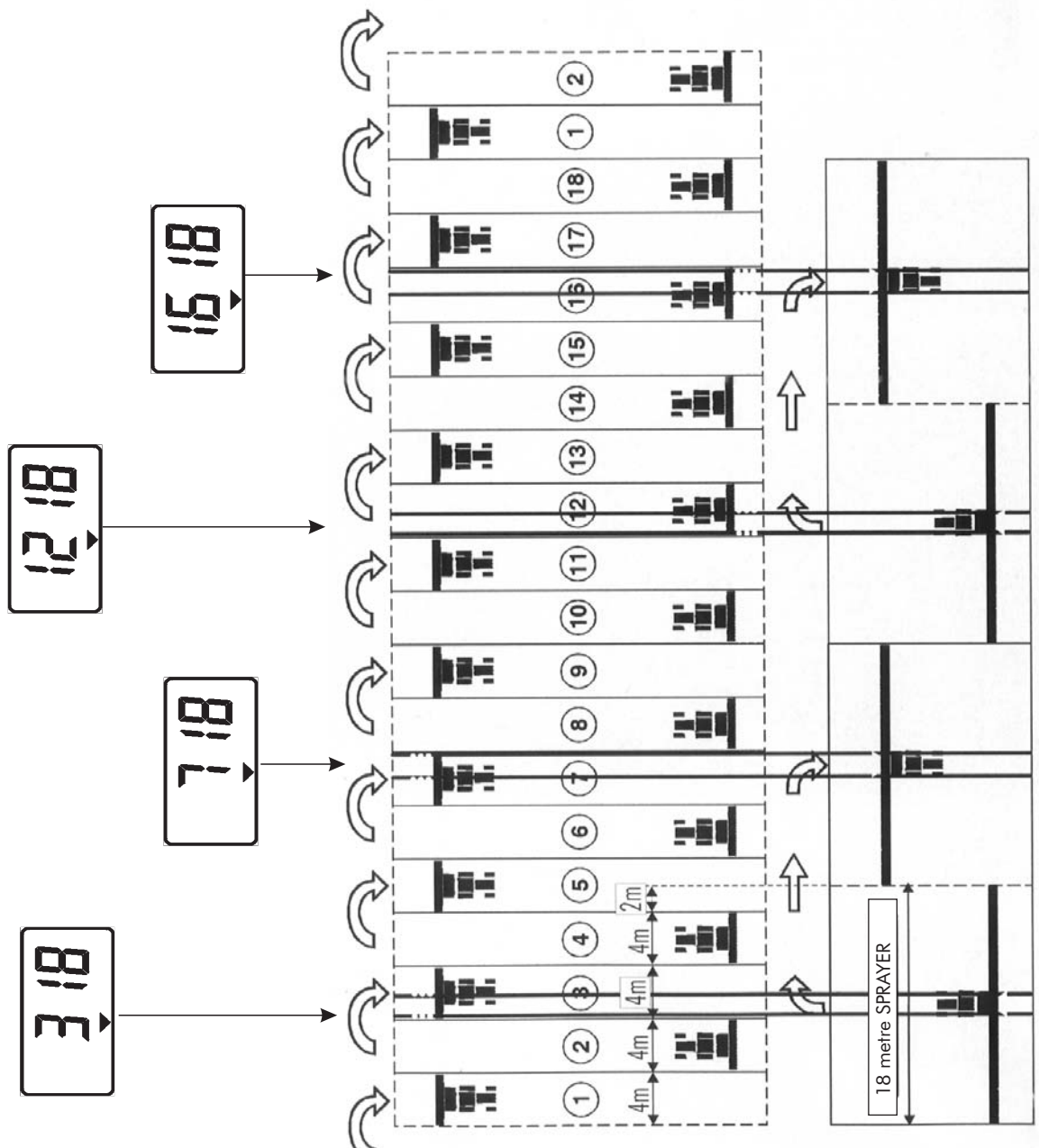

## 6.5 PROGRAMMING THE RATE OF VEHICLE PATH

The circle of the vehicle path marking can be programmed from one (1) to fifteen (15), asymmetrically either to the left or right.

The vehicle path marking can be programmed also for an 18-meter system.

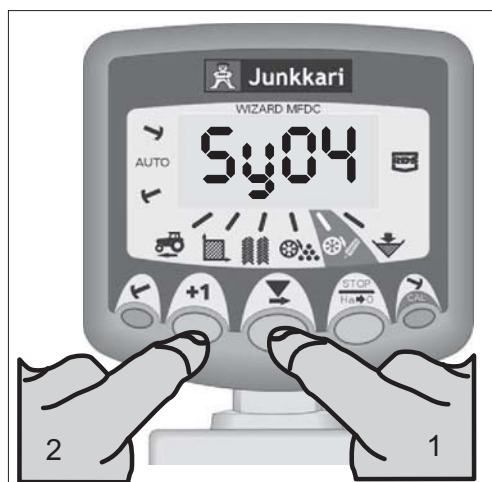

1. Select  action

2. Keep **+1** pressed  
The monitor starts the programming after 3 seconds.

3. Press  and wind the type of vehicle path marking; SY symmetrical, AL asymmetrical left or Ar asymmetrical right.

4. Keep **+1** still pressed, release  for a moment and press it down again. Wind the correct rotation reading on the display. If you want the vehicle path marking off, wind to value 0.

5. When you release the buttons, the selections are saved.

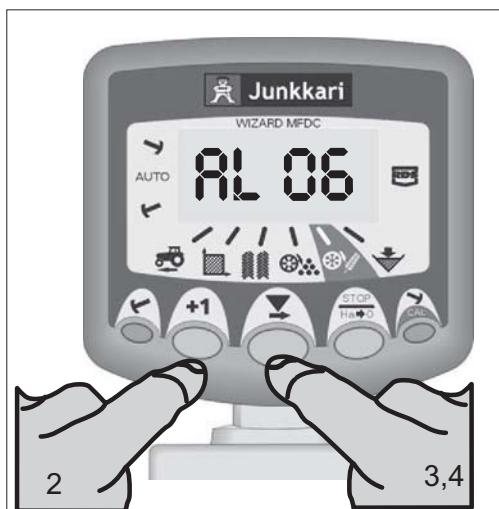
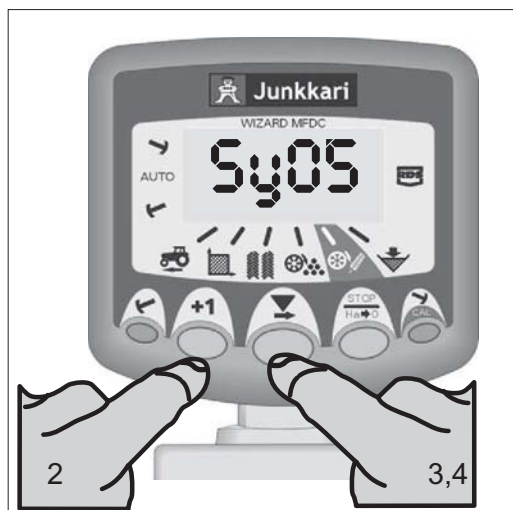

The vehicle path marking can be programmed also for an 18-meter system, but in this case you need 2 additional switchhes.

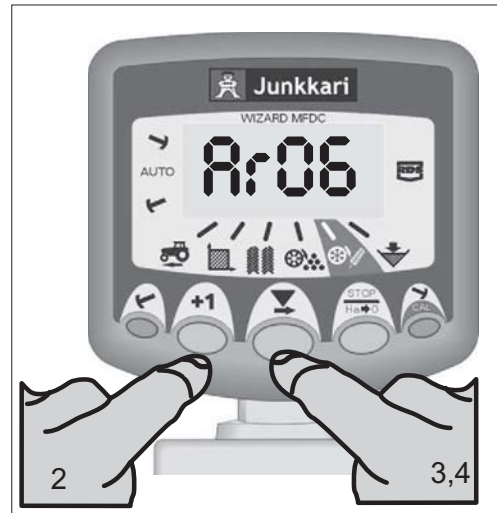

....In this case select As18 on the display.

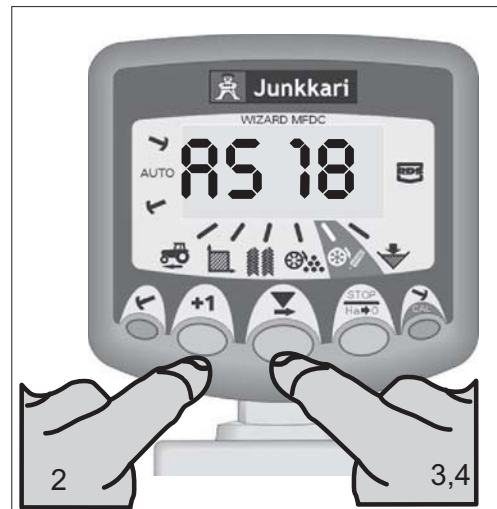



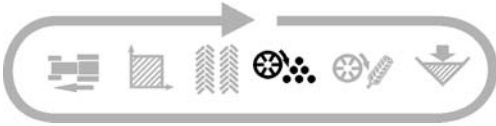

# 7 FERTILIZER DISTRIBUTION SHAFT SPEED/ALARM

## 1. FERTILIZER DISTRIBUTION SHAFT CONTROL



With the default alarm setting, if the fertilizer distribution shaft stops for more than 40 seconds the instrument will sound 5 beeps and will default to the  channel from the current channel selected.

Cancel the alarm by either restoring the shaft rotation, selecting another channel or switching the instrument off and then on again.

Alternatively you can turn off the alarm by pressing and holding the  button for 5 seconds. The  channel will then show "OFF". The alarm function will stay off until the instrument is switched off and then back on again.

Alarm is inhibited if forward speed is less than 2 km/h.

The default low speed alarm is 0 rpm.

## 2. SETTING THE LOW SPEED ALARM

Select the  channel.

**HOLD +1 CONTINUOUSLY**

The instrument enters the programming mode after 3 seconds.

**PRESS  to select digit or decimal point.**

 2.000,  2.000,  2.000,  2.000, etc

**HOLD  to change digit or move the decimal point.**

 2.100,  2.200,  2.300,  2.400, etc

**RELEASE  to select next digit.**

**RELEASE +1 to end programming.** The set values are saved to the device memory.

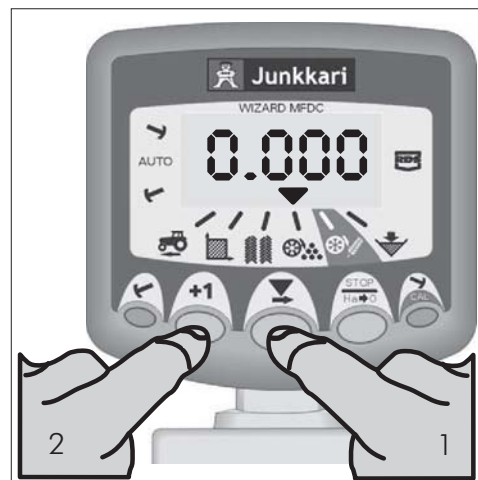

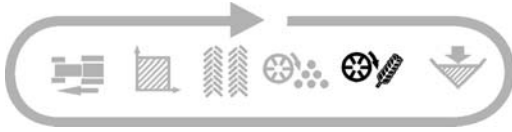

## 8 SEED DISTRIBUTION SHAFT SPEED/ALARM

### 1. SEED DISTRIBUTION SHAFT CONTROL



With the default alarm setting, if the fertilizer distribution shaft stops for more than 40 seconds the instrument will sound 5 beeps and will default to the  channel from the current channel selected.

Cancel the alarm by either restoring the shaft rotation, selecting another channel or switching the instrument off and then on again.

Alternatively you can turn off the alarm by pressing and holding the  button for 5 seconds. The  channel will then show "OFF". The alarm function will stay off until the instrument is switched off and then back on again.

Alarm is inhibited if forward speed is less than 2 km/h.

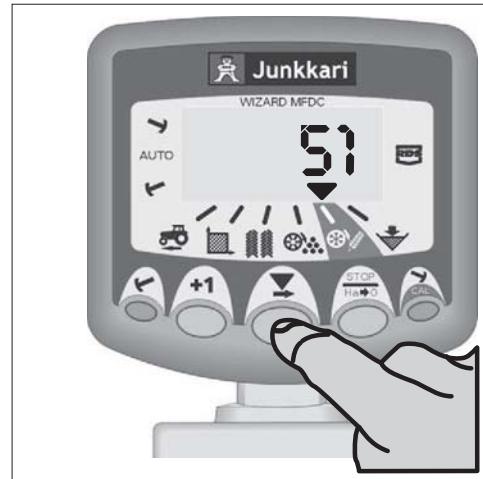

### 2. SETTING THE LOW SPEED ALARM

With the  channel selected, follow exactly the same procedure as for the fertilizer distribution shaft speed channel. (Section 6.)

**NOTE:** Both fertilizer distribution shaft and seed distribution shaft speed are obtained from the tramline device, therefore the instrument will NOT show either shaft speed when on a tramlining bout, and the alarm will be inhibited.

## 9 MACHINERY GUARD

### 1. MACHINERY GUARD

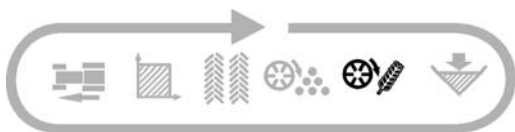

The machinery guard -function is used in machines equipped with tramline clutches. The machinery guard monitors the ratio of the fertilizer and seed side feeding axle rotation speeds. The action will give an alarm if the ratio changes more than the value set in the basic settings at item 6. The permitted deviation by default is 25%.

In the event of an alarm, the cursor moves to the channel; the “err” text is blinking on the display with the current ratio value. The control beeps 5 times at the same time.

For the Simulta-machines programming is done at the factory. It has to be done again if for example seed side chain drive is switched to the small seed position.

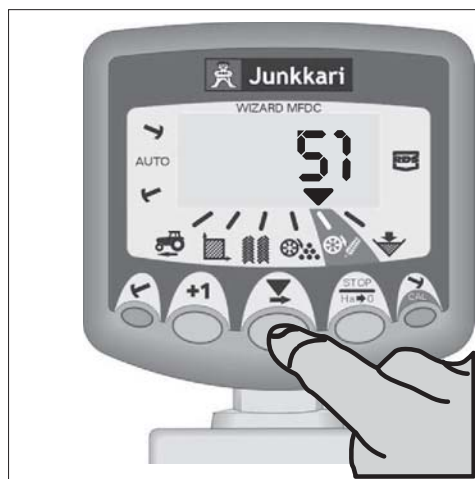

### 2. SETTING THE MACHINERY GUARD

Alarm programming takes place in the working position with the machine moving.

1. Move to channel 5 with button

2. Press the button and the ratio number on the display starts to change.

3. When the reading stabilises in a moment, press the button again. The display will show “DONE” and the value is saved.

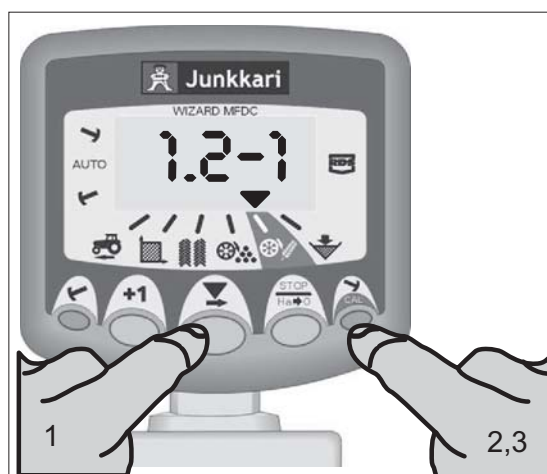

## 10 HOPPER LEVEL

### 1. HOPPER LEVEL ALARM

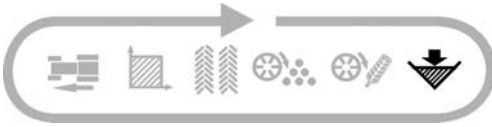

If either the seed or fertilizer level drops below the sensors (fitted in the side of the hopper), the instrument will beep 5 times and will default to the  channel from the current channel selected.



### 2. ENABLE/DISABLE HOPPER LEVEL ALARM

Select the  channel.

PRESS and HOLD **+1** CONTINUOUSLY.

PRESS  to select 0 or 1.

0 = Alarm disabled

1 = Alarm enabled

The display will stay blank when the alarm function is switched off.

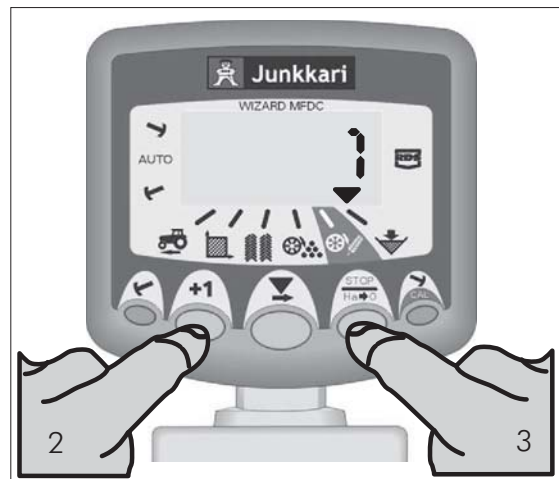



# 11 ROW MARKING

The row marker is on when the Wizard is switched on, and it is in the manual row marking mode.

In the manual row marking mode only one side row marker is in use, either the right or the left one.

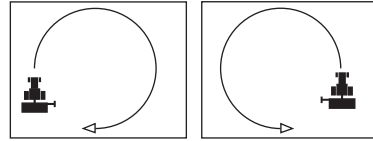

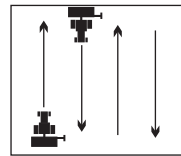

In the automatic row marking mode the right and the left marker alternate, the change of side is done when the drill is lifted. Automatic operation can be started either left or right.

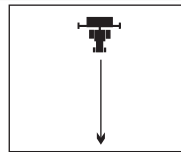

When the row marking is done to both sides of the drill, both markers are lowered down from the Wizard.



## 1. MANUAL ROW MARKING MODE

PRESS (less than 3 secs.) either  or  .

The manual row marking is switched on by pressing either right or left row marker button.

If the row marking is done continuously to the right side of the machine, press the right marker button, and if it is done to the left, press the left marker button.

The function is turned off by pressing the same button shortly again. Until the drill is lifted, the marker will stay lowered and the row marking symbol will flash on the display to remind that the solenoid valve is open (marker lowered).

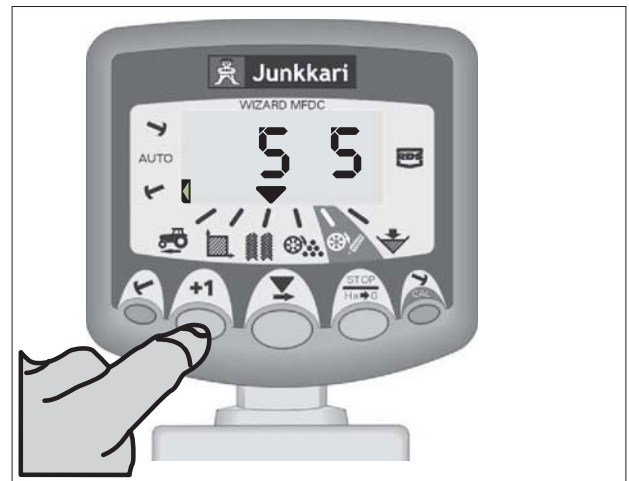

## 2. AUTOMATIC ROW MARKING MODE

HOLD either  or  CONTINUOUSLY.



The instrument enters programming mode after three (3) seconds.

The automatic row marking mode is switched on by pressing continuously either right or left side row marker button, depending on which side of the drill the row marking is required to start from.

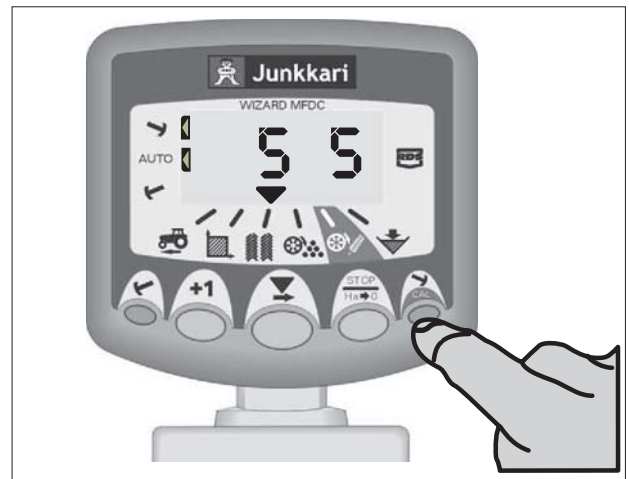
The function is turned off by pressing the same button continuously again.



### 3. SIMULTANEOUS ROW MARKING TO BOTH SIDES OF THE DRILL

PRESS  and  shortly in sequence.

To switch on simultaneous row marking to both sides of the drill, press both row marker buttons in sequence. When the end of the field is reached and it is time to switch to another row marking mode, follow instructions due to what type of row marking is required, see chapters 1 and 2 on last page.

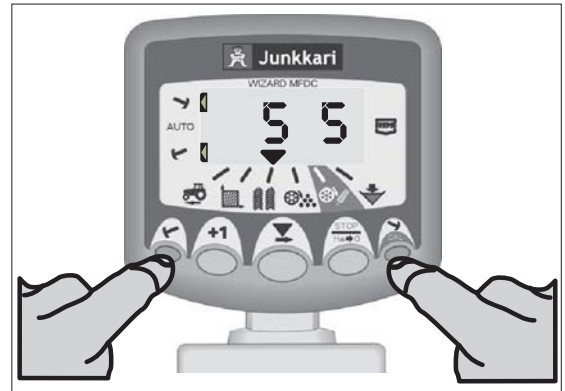

### 4. LIFTING THE DRILL

PRESS **STOP**  to “hold” the current bout when the drill is lifted.



This way the row marker program does not register the lift of the machine as a change of bout even though the row markers are lifted up and lowered down along with the machine. The tramlining function stops as well.

The display flashes “STOP”.

PRESS **STOP**  again to resume the normal bout sequence.



### 5. HOW TO TURN ROW MARKERS ON / OFF

HOLD  and  CONTINUOUSLY to turn on or off the row markers.

The row marking function is turned on and off by holding continuously both marker buttons at the same time for over 3 seconds.

The display, see illustrations below.

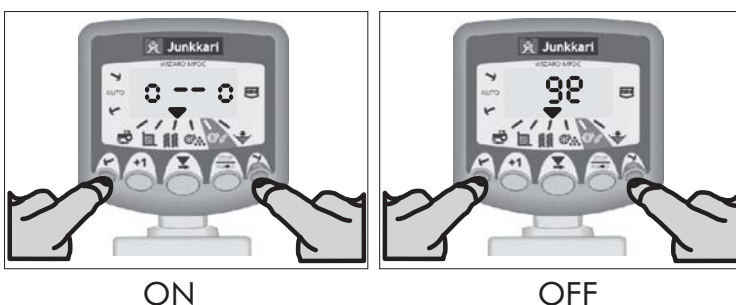
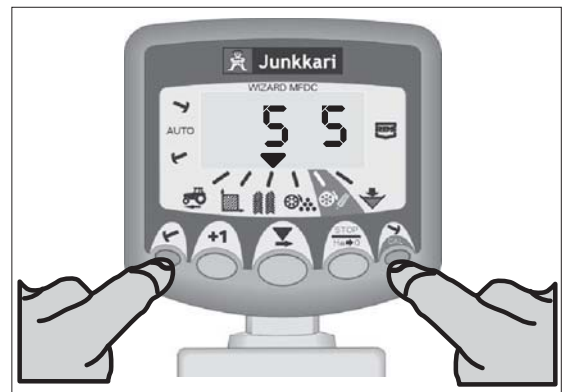

ON

OFF

## 12.3 SOWING TECHNIQUES

It is always recommendable to get acquainted with a new machine or machine model by taking the time to operate the machine in trial run with the hoppers empty. This is especially beneficial if done well in advance of the busy sowing season, so that the operator gets accustomed to the necessary adjustments and the general structural details of the machine.

### SOWING SEASON

The correct timing of the start of the sowing is of fundamental significance to the resulting growth. The starting point is determined mainly by the soil humidity value, which again depends largely on the properties of the soil.

The seeds should be placed into the soil in such a manner that their access to the moisture contained in the soil is preserved, even though the amount of moisture must not be excessive. A rule-of-thumb is that if the soil clings to the tyres, the timing of the starting point of the sowing season should be reconsidered.

The temperature of the soil may be taken as one of the consideration points for the timing of the sowing. The sprouting will take long when the soil temperature remains low and part of the seeds may not sprout at all. Never attempt to sow above a frozen ground layer.

If timing of sowing presents problems due to lack of personal experience, it is advisable to turn to expert advice from, for example, agricultural organizations.

### FERTILIZING

Fertilizing means supplying the plants with nutrients and the requirements can be best determined by a growth potential test. The amount of fertilizer required by the growth is usually calculated on the basis of the fertilizer's nitrogen content. The most suitable of the different fertilizer types, which all have the same nitrogen content, is the one providing also other nutrients, such as trace elements, required by the growing plants. If the chosen fertilizer is lacking in a specific nutrient or if it contains an excess of the same for the plant requirement, the situation may be balanced the following year by choosing a fertilizer with the opposite values for this nutrient. The representatives of the fertilizer manufacturers will help out when determining the requirements of fertilizer based on conditions of the area and the varieties grown on the farm.

The fertilizer should be placed just below the seed row level so that the plants receive the maximum benefits from the fertilizer.

The most beneficial drilling depth for fertilizer is 2-4 cm below the depth of the seeds.

### SEEDS

Each plant variety has its own specific growth density for producing the best yield. A too small quantity of seeds does not give the best yield and may produce late re-sprouting. Too large amount of seeds is again wasteful, does not produce the ideal yield and also one of the causes for easily laid crops.

The required quantity of seeds for sowing a given area must be determined by taking into account the quality of the seed, its germinative capacity, its size, the object of the sowing and the prevailing conditions for growing the crop.

It is usual in grasslands to grow a protective cereal crop over the grass. The best varieties for this purpose are the early, short and stout-stalked grains, for example, barley. To prevent any hindrance to the sprouting of the grass seeds from the protective plant growth, it is advisable to reduce the sowing rate for the latter by 20-40%.

The required quantities of seeds should always be checked and confirmed by the supplier of the seeds or by other, independent experts.

Choose as shallow as possible sowing depth for the seeds for rapid sprouting. Make sure that the seeds are provided with moisture in all possible conditions. Therefore avoid too shallow drilling depths in a soil that is prone to dry up quickly, or the moisture in the top soil evaporates and the seeds are left in a dry ground. On lands, which are lacking in moisture in the springtime, it is advisable to drill the seeds adequately deep, even in spite of a lengthened sprouting period, to ensure a successful crop growth.

The actual drilling depth should always be ascertained from the soil as the sinking of the wheels into the soil, the varying soil conditions and tilling techniques make it impossible to produce generally acceptable tables and charts or measuring methods for the determination of the correct drilling depth to cover all possible variations.

## 13 MAINTENANCE

### READ THE SAFETY INSTRUCTIONS FIRST



#### 13.1 LUBRICATION

Correct lubrication prevents wear and breakdowns during the busy sowing season. The lubricant used must be a good quality multi-purpose grease. Check always when lubricating that the lubrication nipples are unblocked and that the grease gun nozzle is in good condition. The lubricating points are shown in the diagram on page 57 of this manual.

#### 13.2 CLEANING AND STORAGE DURING OPERATING SEASONS

During the operating season the machine should be shielded from rain and the coulters should be kept above ground when the machine is stored outdoors. If left on ground, moisture is condensed inside the coulters and plastic tubing causing obstructions particularly to the fertilizer flow through the feed mechanism and the coulters. We recommended that you empty the fertilizer hopper after each sowing run and lift the machine onto, for example, forklift pallets to rest above ground. The trailed models can be left up supported by the hydraulics providing that the pressure line ball valve is closed and the support leg is used.

The fertilizer feed grooves should be turned fully open before starting a sowing run and from time to time during the actual sowing run. This procedure will loosen any fertilizer stuck in the groove and results in maintaining the correct feed rate. It also prevents any damage to the feed mechanism caused by hard lumps of fertilizer.

#### 13.3 DO-IT-YOURSELF REPAIRS

##### DAMAGED FERTILIZER COULTERS

The fertilizer coulters tip or disc, coulters arm or the springing can often be replaced separately. After you have replaced a coulters or its spring check the attaching screws for tightness after you have operated the machine over a few hectares. Check the coulters tips for wear from time to time. If the coulters tip is worn, alter its adjustment so that the lower surface of the coulters tip remains at least 5 mm below the spur (see Fig. 1).

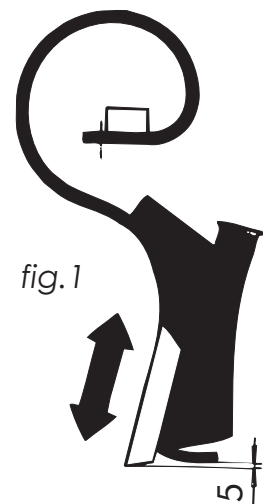

##### DAMAGED SEED COULTERS

The replaceable parts of a seed coulters are the disc, the wearing bit and the coulters arm. If the coulters pivot bearings have got worn, the bearings can either be replaced or tightened down (see 'A' in Fig. 2).

##### FEED ROLLER SEALING RING REPLACEMENT

Remove the threaded mounting flange of the feed mechanism adjusting knob from the side panel and all cotter pins from the shaft. Pull the shaft out through the hole in the side panel. The sealing ring is located in a groove on the side of the feed chamber. Insert a thin knife blade or corresponding between the sealing ring and its locking ring forcing the locking ring out of place to enable replacement of the sealing ring.

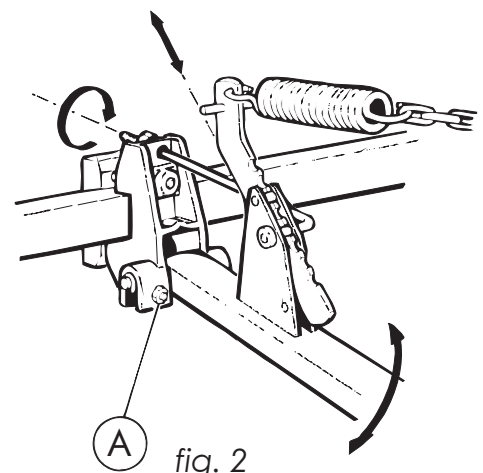



## REPLACEMENT AND ADJUSTMENT OF BOTTOM FLAPS

The condition and the correct adjustment of the bottom flaps affect the feed rate considerably. The flap adjustment has been carried out at the factory, but it is always possible that clumped fertilizer, foreign objects etc. may damage a bottom flap despite of its safety release spring. A damaged bottom flap should be replaced by a new one or, if the damage is only slight, it is sufficient to correct the condition by re-adjustment.

### BOTTOM FLAP REPLACEMENT

Remove all the hairpin fasteners from the bottom flap operating shaft and mark out the locations of the other parts on the shaft to help in the correct assembly later. Remove the seed side adjustment screw locking to enable the withdrawal of the shaft. The bottom flap can be removed and replaced after you have turned the feed rate adjustment to zero reading. Place the assembled bottom flap inside the feed chamber and refit the operating shaft. Check that all flaps stay in the same position in relation to the hexagonal shaft. Re-attach all the parts removed in the process of repair (see Fig. 3).

### INDIVIDUAL ADJUSTMENT OF BOTTOM FLAPS

The basic adjustment of the bottom flap spring is correct when the marked distance in the drawing on right is 26 mm. The bottom flap position can be adjusted into both directions within the normal range of adjustment. Tightening of the adjusting screw by one turn increases the feed rate by 7%. Conversely, loosening the screw decreases the feed rate. All bottom flaps in each feed chamber must be similarly adjusted. Move the central adjustment lever into position 1, to enable the checking of the clearance between each flap and its feed roller by your fingertip. The correct clearance is about 0.5 mm. The clearance adjustment has been carried out at the factory for all new machines (see Fig. 3).

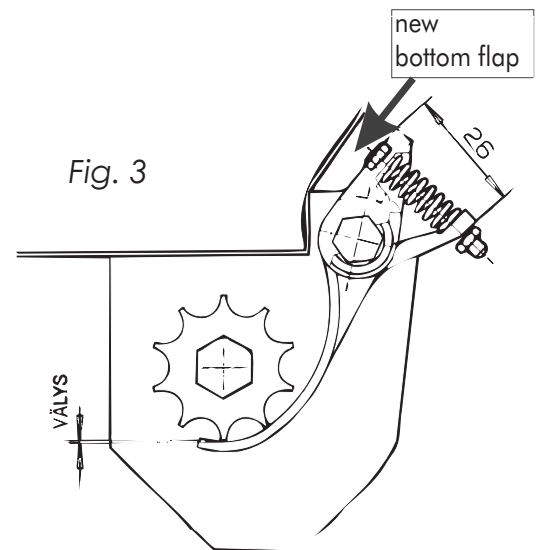

### CENTRAL ADJUSTMENT OF THE BOTTOM FLAPS

If the calibration test results differ markedly from the values given in the Sowing Chart, the machine may be trimmed towards the chart values within certain limits. It is only natural that there occurs even quite significant differences in the flow characteristics of both seeds and fertilizer. So it is not recommendable to commence a major adjusting procedure to correct slight deviations. The adjustment is carried out by altering the position of the adjusting lever locking latch. The effect of the adjustment is about 1.5% for each 1 mm movement so that tightening of the latch reduces the sowing rate. The limiting value for the tightening is that a clearance should remain between the flap and the feed roller when the central adjusting lever is moved to its position 1 (see Fig. 3).

### TYRE REPLACEMENT

The quickest way to remove a wheel from the 2500 T model is to remove first the wheel shaft bearings. After this, lift up the bogie frame and support the wheels in this position in such a way that the bearing cap screws can be removed while leaving the bearings still in their places. Remove the support blocks and let the wheels down, so that they can be withdrawn from below the bogie frame.

The best way to change tyres to models 3000 and 4000 is to remove the bogie half where the wheel should be changed. In case of the left bogie, the drive chain must also be removed.

This is done by removing the bogie half from the bogie carrier, in model 3000 there are 2+2 pcs of M16 screws, and in model 4000 4+4 pcs of M16 screws. Then the machine is lifted up either by using a jack lift, or for example, tractors front loader. When the machine is being lifted up, the bogie half can be drawn from under the machine. When the bogie half is off from under the machine, it can be easily disassembled, and desired wheel(s) can be changed. In case the wheel axle has to be removed, remember to keep the order of the wheels and hubs the same as it was.

The bogie half is re-assembled by placing it under the machine and lowering the machine down on it. Then fix the bogie carrier to the bogie half and tighten screws with care.



NOTE : When the drill must be lifted up, make sure that the capacity of the lifting device is adequate to lift the machine safely !

## CLUTCH ADJUSTMENT

It is possible to adjust the clutching/de-clutching point of the feed when raising or lowering the towed drill by adjusting the limit screw of the coupling sprocket. Tighten the locking nut after the adjustment. The basic adjustment has been set at the factory (see Fig on the right).

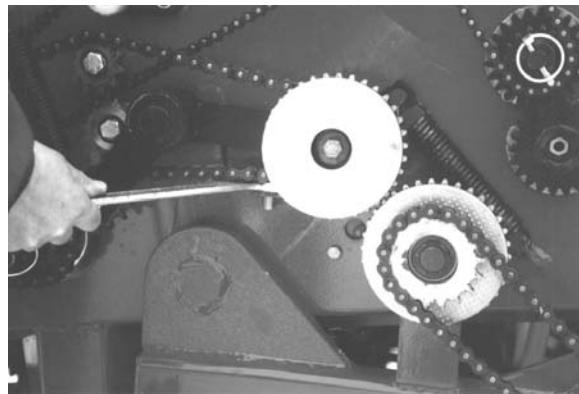

## TYRE PRESSURES

The tyre pressures used affect the total ground pressure exerted by the machine. This in turn affects the compactness of the soil. It is worth noting that by using a smaller ground pressure also means having a lower carrying capacity. The carrying capacity is directly related to the machine's transport speed, so that when using tyre pressures, which are lower than the maximum allowed, the transport speed of the machine must also be lowered. The tyre pressure values given in the tables below have been determined on the basis of the machine weight and the travel speed of 30 k.p.h. (18.7 m.p.h.), which is the structural top speed value for the tyres. When sowing, the function of the tyres is to act as packing rollers over each sown row. Thus it is advisable to use tyre pressures as near the max. values as possible to improve the compression effect on soil especially on soils lacking in spring moisture. It is recommendable to use maximum tyre pressures on stony fields.

The tyre pressures must be inspected in the beginning of every sowing season with a pressure gauge and visually daily during the season.

Tyre size	Tmodel	STmodels	max. press
7.00-12	6ply	165 kPa	250 kPa
7.50-16	6ply	200 kPa	280 kPa

## 13.4 WIRING DIAGDRAM

wiring diagram for lighting equipment:

1. LEFT TURN SIGNAL
2. UNOCCUPIED
3. GROUNDED TO FRAME
4. RIGHT TURN SIGNAL
5. RIGHT REAR LIGHT AND LICENCE PLATE LIGHT
6. BRAKE LIGHT
7. LEFT REAR LIGHT

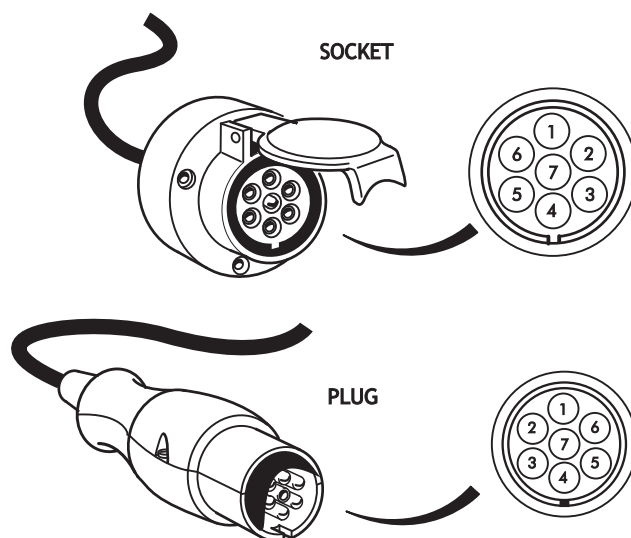
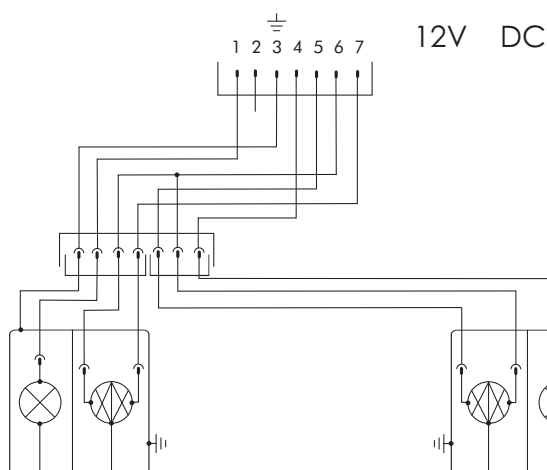

# ELECTRICAL CONNECTORS

## 16-PIN DATA TRANSFER CABLE CONNECTORS

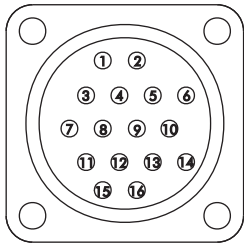

NR	CABLE COLOR
1	RED
2	RED-BROWN
3	YELLOW-RED
4	GREEN
5	VIOLET
6	BROWN
7	WHITE
8	YELLOW
9	TURQUISE
10	PINK
11	BLACK
12	GREY
13	GREEN-RED
14	BLUE
15	ORANGE
16	RED-BLUE

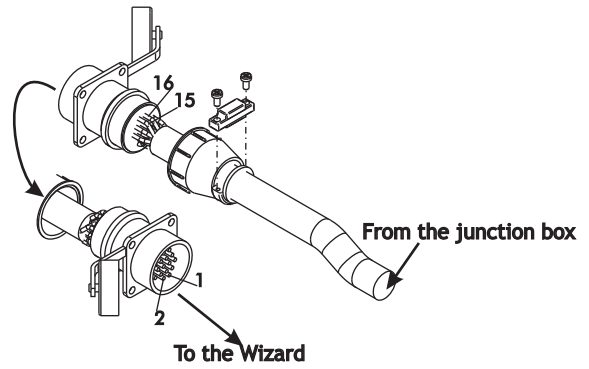

## 3-PIN CONNECTOR

from the junction box

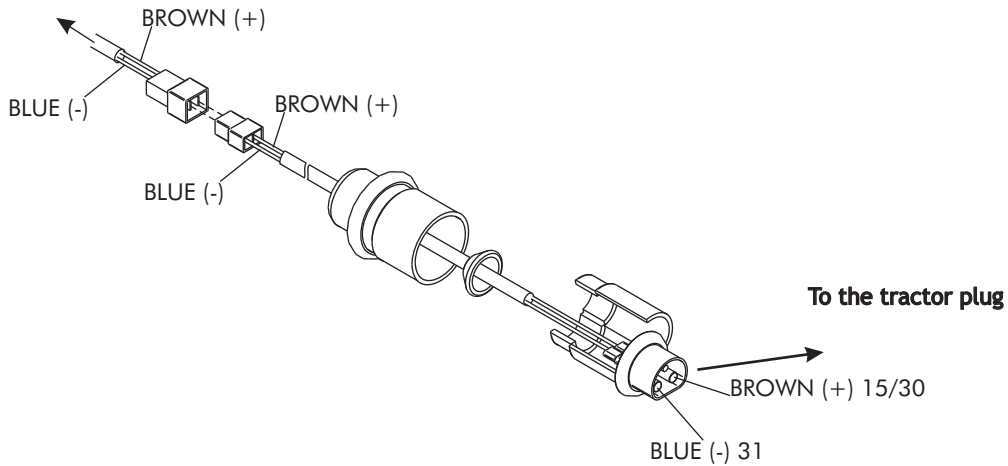

## TRAMLINE MARKER CONNECTORS

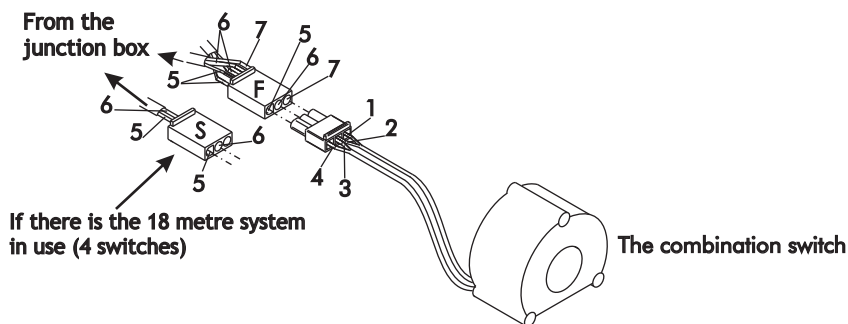

NR	CABLE COLOR
1	BLACK
2	DARK BLUE
3	PURPLE
4	LIGHT BLUE
5	BROWN
6	BLUE
7	YELLOW-GREEN

## THE ROW MARKER SOLENOID CONNECTOR

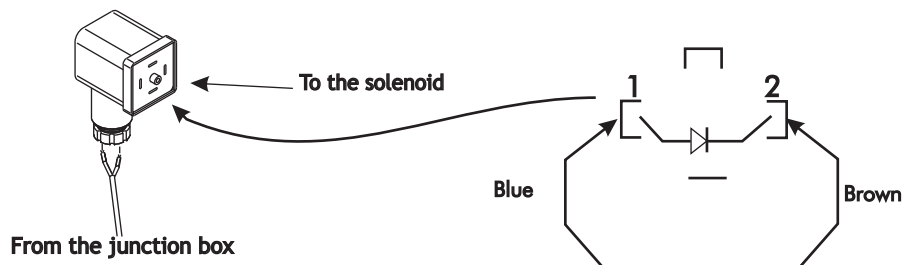

Wiring diagram, Wizard:

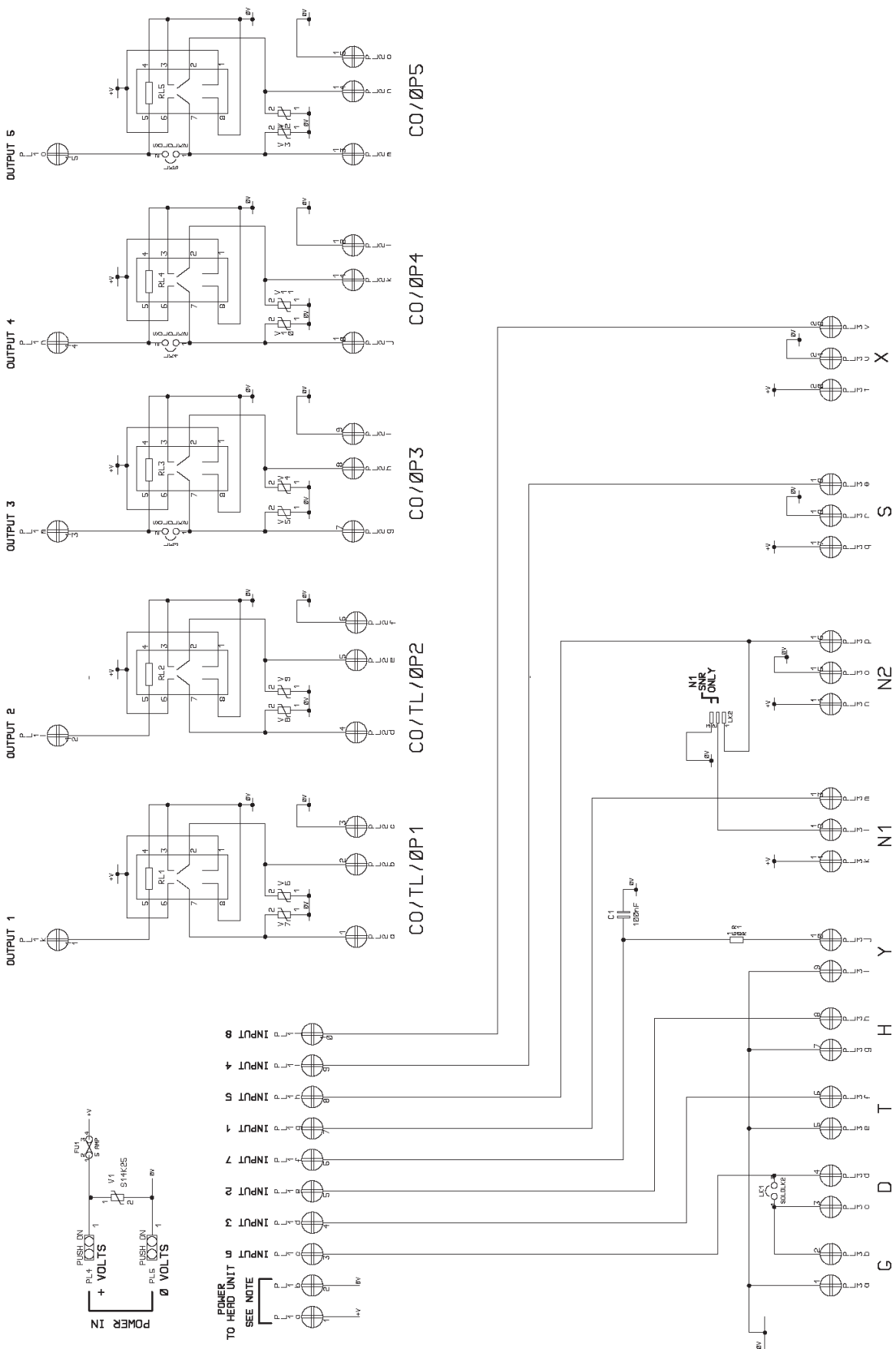

Junction box wiring label, Wizard

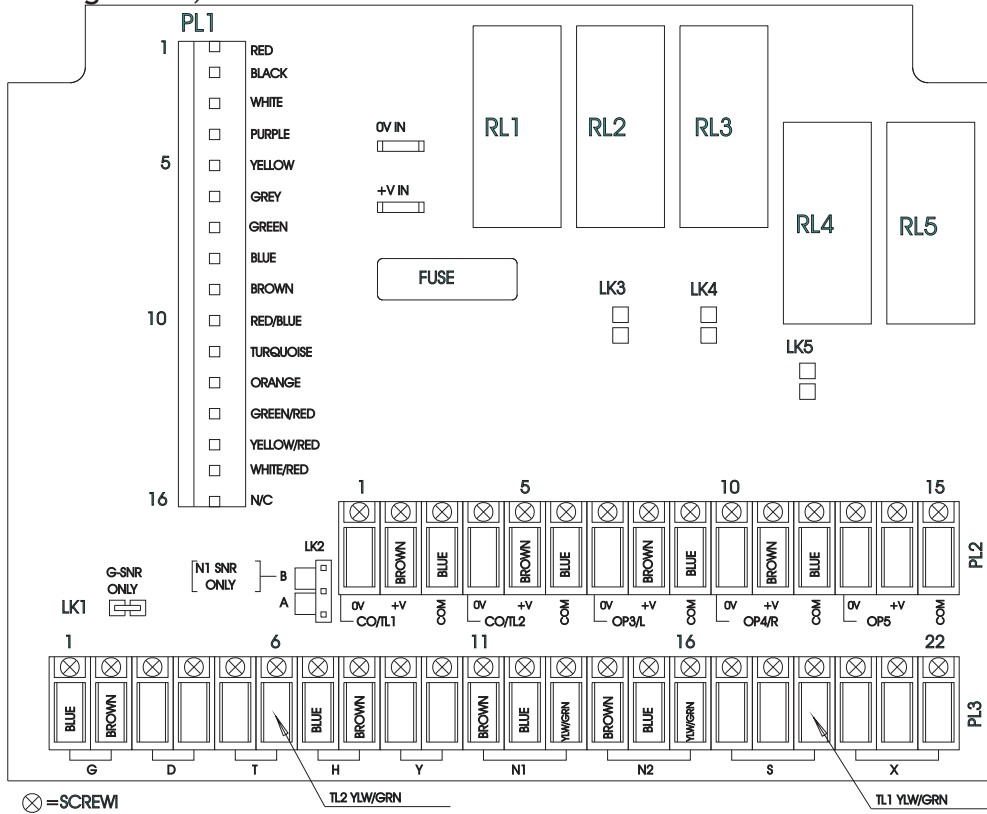

14 LUBRICATION CHART

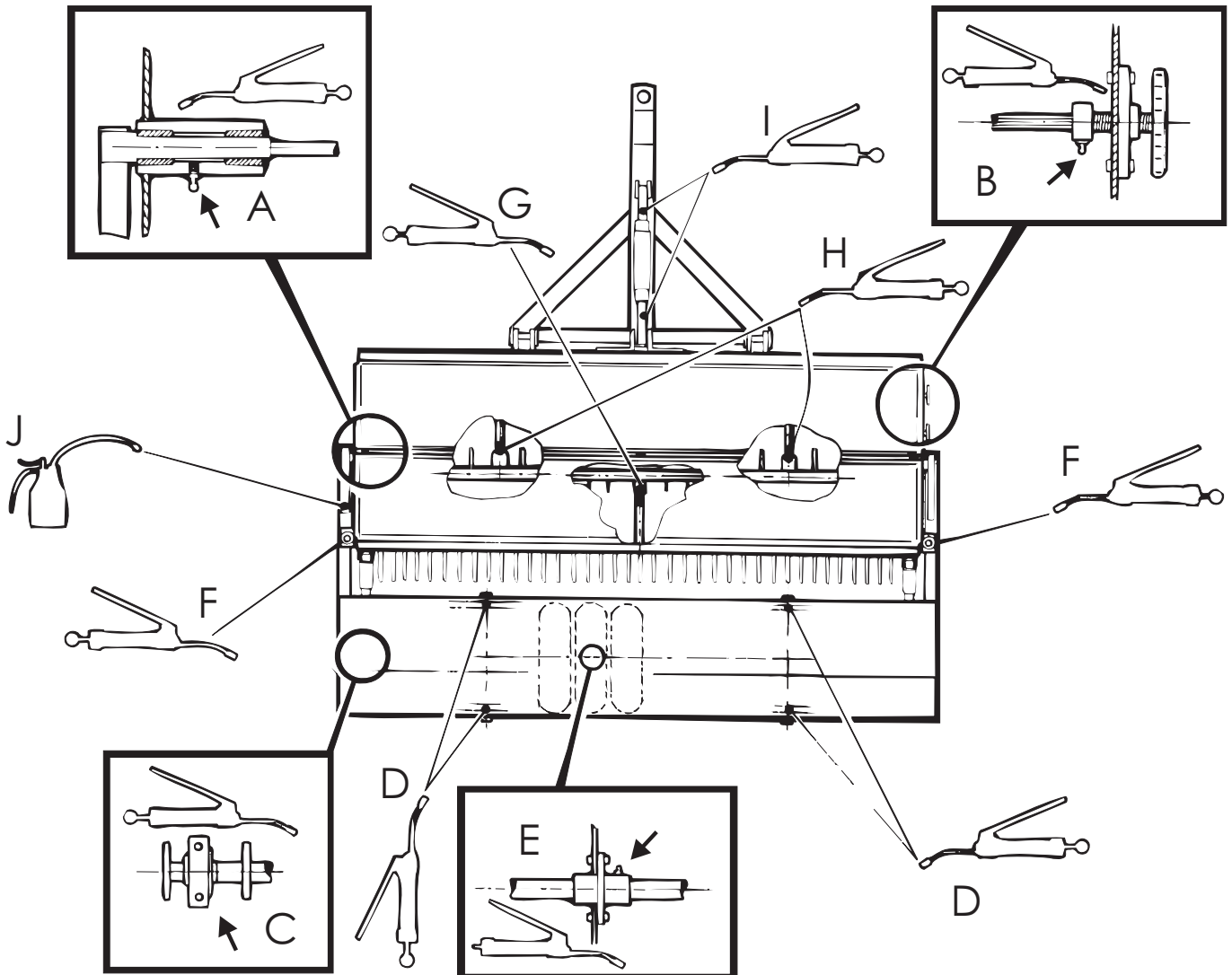



TARGET		S2500	S3000	S4000
A.	Arm bushings 2kpl	every 200 hours or twice in a season	every 200 hours or twice in a season	every 200 hours or twice in a season
B.	Feed adjustment 2kpl	Every 200 hours or twice in a season	every 200 hours or twice in a season	every 200 hours or twice in a season
C.	Wheel bearings	Twice in a season 4 pcs	Twice in a season 8 pcs	Twice in a season 8 pcs
D.	Bogie bearings	Twice in a season 4 pcs	Twice in a season 4 pcs	Twice in a season 4 pcs
E.	Free wheel Bearings	Twice in a Season 4 pcs	Twice in a season 6 pcs	Twice in a season 7 pcs
F.	Height adjustment 2kpl	Twice in a Season	Twice in a season	Twice in a season
G.	Central adjustment 1kpl	Twice in a season		
H.	Central adjustment 2kpl		Twice in a season	Twice in a season
I.	Top link threads 2kpl	Twice in a season	Twice in a season	Twice in a season
J.	Drive chains	Daily	Daily	Daily

The screw threads must be lubricated with a good quality vaseline or appropriate general lubricating grease. Turn each threaded portion once fully in and fully out after applying the lubricant to spread the lubricant evenly over the whole length of the thread. It is recommended to lubricate the drive chains with biological oil.

## 15 OUT-OF-SEASON STORAGE

### 15.1 CLEANING FOR STORAGE

The drill is emptied of all seeds and fertilizer. Wash the machine thoroughly both inside and out with clean water. Clean all electrical system components with a clean, damp cloth.



NOTE. Do not use a pressure washer for cleaning. Do not spray the electrical system components with water or any cleaning liquids.

### 15.2 WINTER STORAGE

When the machine is left unused after an operating season, it must be stored in a covered space after having been cleaned and lubricated. The machine must be cleaned carefully and its paintwork checked after the cleaning. Any scratches or other damage to the paintwork should be repaired by painting over the damaged spots. Carry out a full lubrication routine on the machine. The drive chains should be removed and cleaned in petrol or kerosene and oil-bathed after cleaning.

The machine will survive the winter period without rusting the best, when it is wiped over with a rag dipped in mineral or vegetable based oil.



Never use other than new, clean oil for rust prevention during winter storage as old, used oils contain sulphur and other combustion residues. These will increase the risk of corrosion in areas not protected by paint. It is also forbidden to use synthetic oils for corrosion prevention.

The hydraulic cylinders should also be fully retracted to prevent rusting of the piston rods. Loosen the screws of the central adjusting mechanism in order to relieve the spring pressures in the coulters. All removable electronic display units and encased control units should be stored separately in a dry and warm environment. It is also advisable to check the tyre pressures before leaving the machine into storage.

As the storage period of a seed/fertilizer drill tends to be long, careful attention to preparation procedures is especially important with regard to the durability of the machine.

## 16 TROUBLESHOOTING CHART

FAULT	CAUSE	REMEDY
Calibration test does not comply with chart values	Faulty adjustment	Check adjustment
	Faulty direction of rotation	Check direction of rotation
	Faulty number of turns in the test	Check
	Faulty bottom flap position	Check
	Note the guidance aspect of the chart	Carry out a trial run as necessary
Feed rate lower than calibration test indicates	Calibration test not properly done	Re-test
	Clutch engagement improper	Re-adjust clutch
Feed rate higher than calibration test indicates	Calibration test not properly done	Re-test
	Machine vibration may sometimes increase the flow of seed	Carry out a trial run as necessary
Feed rate varies between individual feed chambers	Bottom flaps in different positions	Adjust
	Feed groove positions in relation to feed chambers vary	Adjust
Electric areal meter does not operate and indicator light is off	Lights not switched on	Switch on parking lights
	Connector corroded	Clean connector
	Broken wiring	Repair
Electric areal meter does not operate even when indicator light is on	Connector corroded	Clean connector
	Broken wiring	Repair
	Damaged sensor	Replace
Excessive wear in fertilizer coulters	Coulter tip runs too high	Adjust position
Excessive wear in fertilizer coulters	Soil conditions hard and wear-inducing	Replace tips with hard-faced or hard alloy tips
Seed coulter bent upwards	Coulter struck stone in field	Replace coulter arm
Seed coulter bent downwards	Coulter struck obstacle when reversing the machine	Replace coulter arm
Monitor will not turn on	Voltage is below 8V	Take care that there is enough power reserve, e.g. charge the battery in time.
“BATT” on the display	Supply power below 10V, there is just enough power to show this announcement	Check the condition of the power supply, and make sure that there is enough power available.
“PROG” on the display	The computer memory has been degenerated	Contact the nearest service or the dealer
TL1 flashes on the display	Dirt or something on the switch of the seed side, that causes divergent action of the switch	Turn the calibration lever half (1/2) bout clockwise, check the switch and replace if needed.
	The cable is broken	Repair the cable
TL2 flashes on the display	Same cause as previous, but on the fertilizer side	Same remedy as previous

FAULT	CAUSE	REMEDY
The display does not show the forward speed	Magnet or sensor bracket loose	Fix the magnet/sensor bracket again
	Broken cable	Repair cable
	Distance between sensor and magnet too wide	Adjust the distance between magnet and sensor
Defect on tramlining	Same cause as previous	Same remedy as previous
Tramline bout does not show or instrument does not count the bouts	The tramlining has been switched OFF	Switch ON the tramlining to appropriate mode
	The tramlining has been stopped	Press STOP to continue tramlining
Area does not show on the display	See paragraph "The display does not show the forward speed"	See paragraph "The display does not show the forward speed"
Incorrect area and forward speed on the display	The sensor calibration was unsuccessfully performed	Re-calibrate the speed and area counter
The hopper level alarm does not alarm even when the hopper is totally empty	The hopper level alarm is switched off	Switch ON the alarm
	The cable is broken	Repair or replace cable
The hopper level alarm alarms continuously	Either the seed or the fertilizer level has dropped below the sensors	Switch off the hopper level alarm when performing the small seed sowing
Cursor on five channels. Display flashes "err" and numbers	The machine guard sounds an	Check that the machinery is rotating evenly. If there is nothing wrong in the machinery, re-program the guard.

The normal operational wearing that takes place in the seed and fertilizer drill processes safely and will cause no dangerous situations.



Note that if the machine is operated in any manner contrary to the road safety regulations or the given safety instructions or if it is overloaded or left without proper maintenance the danger of unusual wear or failure of a component part always exists. This might present a risk of personal injury or environmental damage.

## 17 WITHDRAWAL FROM ACTIVE USE

### READ THE SAFETY INSTRUCTIONS



When the product is withdrawn from active service the responsibility of handling the matter rests solely on the product's end-user or the person or enterprise, in whose ownership the product is at that date.

The disposal of the machine and the various resulting waste materials is governed by national laws, instructions and regulations, which are to be complied with. This applies to all countries, where the product is marketed.

Most of the component parts of a seed drill are of materials, which do not disintegrate in nature. This makes it necessary to disassemble the machine and to dispose of the various materials according to national regulations.

- Steel and other metallic parts are recycled through scrapyards or stripping yards for re-use.
- Waste oil, plastic parts and rubber components, other than tyres, are disposed of as hazardous waste by recycling, taking them to a refuse dump or disposed of by other means according to national regulations.
- Tyres must be disposed of in accordance with the directives 83/189 EY, 182/88/EY, 94/10/EY by returning the used tyres to recycling points or to an recycling operator, who will forward the tyres for re-processing.

Environmental authorities will supply further information on handling the scrapping and the resulting waste materials.



## 18 TERMS OF WARRANTY

1. The warranty period is 12 (twelve) months when used for agricultural purposes within the scope of operation to which the machine has been intended for.
2. In communal, industrial or commercial contract work the warranty period is 6 (six) months.
3. The warranty period shall begin from the date of the machine's delivery to the customer by the authorized Distributor/Dealer.
4. The warranty is limited to manufacturing and material defects in the product. The failed part(s) will be repaired or exchanged for reconditioned part(s) either by the factory or an authorized repair workshop. The subcontracted machine components are covered by the respective warranty policies of their manufacturers.
5. A repair carried out and covered by the warranty does not constitute any elongation of the warranty period.
6. The warranty does not cover faults or damages caused by operating practices which are incorrect or contrary to the practices outlined in this manual, by incorrect maintenance, excessive loading or normal wear. The warranty shall neither extend to cover any subsequential damages, down-time, traveling expenses, freight charges, daily allowances, overtime work nor any modification work on the machine's original design.

In matters related to the warranty, please contact your local Dealer, who will prepare a warranty claim on the subject matter. Before any action is taken to correct the fault or defect, the proposed procedure and possible expenses thereof must be agreed with by the manufacturer.

The warranty shall apply only if the warranty registration form is returned duly filled to the manufacturer within 14 (fourteen) days from the date of the machine's delivery to the customer.

## 19 SCOPE OF LIABILITY

The manufacturer of the product shall not be held liable for the consequences if the said product is used in a way contrary to common law, safety instructions or the instructions contained in this manual. When operating the machine, situations may arise, which are unforeseen and therefore not covered by any specific instructions. The operators are therefore advised in such cases to act according to general, machinery-related safety regulations and directives.

Please note that the incorrect application of fertilizer or seed dressing may prove damaging to people, animals, waterways or soil. Always comply with the instructions given by the manufacturer of the materials or by other experts on the matter to ensure correct handling and application of these substances.

The manufacturer shall not be responsible for any damages caused by incorrectly chosen seed, pesticide or fertilizer for any application. Experts should be consulted for advice if personal knowledge and experience is not sufficient for correct decision-making.

The manufacturer shall neither be held responsible for a poor growth resulting from the use of the product. The operator must keep an eye at all times on the sowing rates for both seeds and fertilizer thus to ensure that the quantity of sown material remains at a level, deemed suitable, in all feed chambers. The operator must also continually observe that the proper sowing depths are maintained.

The manufacturer of the product shall not be responsible for damages caused by the use of subcontracted components.

The manufacturer shall not be responsible for any damages to other machinery and equipment which may be caused by the use of the seed and fertilizer drill.

The manufacturer reserves the right to further develop or alter the construction of the product.

The owner of the seed and fertilizer drill shall be held responsible to oversee that each and every person operating the machine has acquainted himself/herself with the operating and safety instructions outlined in this manual and fully understood all such instructions.



**EY -VAATIMUSTENMUKAISUUSVAKUUTUS KONEESTA**

**(FI)**

Valmistaja  
Osoite

Junkkari Oy  
Pohjanmaanväylä 5, FIN-62375 YLIHÄRMÄ

Vakuutamme yksinomaan omalla vastuullamme, että markkinoille saatettu kone

**JUNKKARI SIMULTA 2500 T/3000 T/3000 ST/ 4000T/ 4000 ST**

valmistenumeroista **101** alkaen on soveltuville osin rakennettu normatiivisten asiakirjojen ohjeiden mukaan ja noudattaa direktiivien 98/37/EY määräyksiä

**EG- FÖRSÄKRAN OM ÖVERENSSTÄMMELSE FÖR MASKINELL UTRUSTNING**

**(SE)**

Tilverkare  
Adress

Junkkari Oy  
Pohjanmaanväylä 5, FIN-62375 YLIHÄRMÄ

Försäkrar härmed enbart på vårt eget ansvar, att för marknader tillverkad maskin

**JUNKKARI SIMULTA 2500 T/3000 T/3000 ST/ 4000T/ 4000 ST**

f.o.m tillverkningsnummer **101** är tillverkad i tillämplig mängd i överensstämmelse med instruktioner av det normativa dokumentet följer bestämmelser av följande direktiver: 98/37/EY

**EC DECLARATION OF CONFORMITY FOR MACHINERY**

**(EN)**

Manufacture  
Address

Junkkari Oy  
Pohjanmaanväylä 5, FIN-62375 YLIHÄRMÄ

Herewith declare on our sole responsibility that for the market produced machine

**JUNKKARI SIMULTA 2500 T/3000 T/3000 ST/ 4000T/ 4000 ST**

from the manufacturing number **101** is manufactured, where applicable, in conformity with provisions of the instructions of the normative document according to the following directive: 98/37/EY

**DECLARATION CE DE CONFORMITE POUR LES MACHINES**

**(FR)**

Fabricant  
Adresse

Junkkari Oy  
Pohjanmaanväylä 5, FIN-62375 YLIHÄRMÄ

Certifions á nos propres risques, que la machine suivante commercialisée

**JUNKKARI SIMULTA 2500 T/3000 T/3000 ST/ 4000T/ 4000 ST**

et ce depuis le numéro de série **101** est en conformité avec les normes applicables et les dispositions de la directive 98/37/EY

**EG-KONFORMITÄTSEKTLÄRUNG FÜR MASCHINEN**

**(DE)**

Hersteller  
Adresse

Junkkari Oy  
Pohjanmaanväylä 5, FIN-62375 YLIHÄRMÄ

Erklären hiermit ausschließlich auf eigene Verantwortung, daß die Maschine

**JUNKKARI SIMULTA 2500 T/3000 T/3000 ST/ 4000T/ 4000 ST**

von der Herstellungsnummer **101** konform mit den einschlägigen Bestimmungen von dem normativen Document hergestellt ist und Bestimmungen von Direktiven: 98/37/EU

**EC SAMSVÆRSERKLÆRING OM MASKINER**

**(NO)**

Produsent  
Adresse

Junkkari Oy  
Pohjanmaanväylä 5, FIN-62375 YLIHÄRMÄ

Erkærer at produktet beskrevet heretter

**JUNKKARI SIMULTA 2500 T/3000 T/3000 ST/ 4000T/ 4000 ST**

f.o.m Tillverkningsnummer **101** Som omfattes av denne erklæringen, er i samsvar med instruksjonene i dokument samt bestemmelsene i følgende direktiv: 98/37/EY.

**TOEND MASINA NOUTELEVASTAVUSE KOHTA****(EE)**

Valmistaja Junkkari Oy  
 Aadress: Pohjanmaanväylä 5, FIN-62375 YLIHÄRMÄ

Kinnitamme ainuüksi omaenda vastutus el, et turule lastud masin

**JUNKKARI SIMULTA 2500 T/3000 T/3000 ST/ 4000T/ 4000 ST**

valmistusnumbrid **101** on ehitatud normatiivsete dokumentide juhiste kohaselt ja vastab direktiivi 98/37/EY nõustele

**ZAPEWNIENIE ZGODNOSCI URZADZENIA Z WYMAGANIAMI****(PO)**

Producent Junkkari Oy  
 Adres: Pohjanmaanväylä 5, FIN-62375 YLIHÄRMÄ

Zapewniamy wyłączenie na własną odpowiedzialność, że wprowadzona do sprzedaży

**JUNKKARI SIMULTA 2500 T/3000 T/3000 ST/ 4000T/ 4000 ST**

począwszy od nr fabrycznego **101** jest skonstruowana w zakresie stosowalności zgodnie z normatywną dokumentacją i przepisami dyrektywy: 98/37/EY

**CEE DECLARACIÓN DE CONFORMIDAD PARA MAQUINARIA****(ES)**

Fabricante: Junkkari Oy  
 Dirección: Pohjanmaanväylä 5, FIN-62375 YLIHÄRMÄ

Declara en su misma responsabilidad que la máquina construida modelo:

**JUNKKARI SIMULTA 2500 T/3000 T/3000 ST/ 4000T/ 4000 ST**

con el numero de fabricación **101** está fabricada con conformidad a las prescripciones de la normativa referente a la siguiente directiva: 98/37/EY

Ylihärmässä 25.10.2005



Arto Aro  
 Teknillinen Johtaja  
 Technical Director